

## SEDM-L

### Multi compartment smoke control damper

Technical Documentation

Installation, Commissioning, Operation, Maintenance and Service Manual



These technical specifications state a row of manufactured sizes, main dimensions, design and range of use of multi compartment smoke control dampers SEDM-L.

It is valid for production, design, ordering, delivery, storage, assembly, operation, maintenance and serviceability checks.

# CONTENT

I. GENERAL.....	3
Description.....	3
II. DESIGN.....	5
Design with actuating mechanism.....	5
III. DIMENSIONS.....	9
Technical parameters.....	12
IV. INSTALLATION.....	15
Placement and installation.....	15
Transport of the damper to the installation place and the installation procedure.....	17
Statement of installations.....	22
In solid wall construction.....	23
In gypsum wall construction.....	28
In shaft wall construction.....	30
In solid ceiling construction.....	31
Installation damper into/onto smoke extraction ducts.....	32
V. SUSPENSION SYSTEMS.....	34
Example of duct connection.....	37
VI. TECHNICAL DATA.....	38
Pressure loss.....	38
Noise data - level of acoustic output corrected with filter A.....	43
VII. MATERIAL, FINISHING.....	47
VIII. TRANSPORTATION, STORAGE AND WARRANTY.....	47
Logistic terms.....	47
Warranty.....	47
IX. ASSEMBLY, ATTENDANCE AND MAINTENANCE.....	47
Electrical connection of the actuator in protection box.....	48
Entry into service and revisions.....	49
X. ORDERING INFORMATION.....	50
Ordering key.....	50
Accessories.....	51
Data label.....	51

# I. GENERAL

## Description

Smoke control dampers - SEDM-L are designed into an inlet or extract smoke ventilation system. The dampers are designed either to close to provide compartmentalization or to open (for fresh air inlet) or to allow removal of the heat and combustible products from a fire in the affected fire zone/compartment.

The damper blade is controlled by electrical actuating mechanism.

Dampers are fire resistant and are intended for systems with manual or automatic activation.

Dampers are designed for using in fire compartments that can be connected to the smoke exhaust ducts (tested according to EN 1366-8) or they can be installed in or on the construction of the fire compartment.



### Damper characteristics

- CE certified acc. to EN 12101-8
- Tested in accordance with EN 1366-10
- Classified acc. to EN 13501-4
- External Casing leakage class ATC 3 (old marking "C")
- Internal leakage min. class 3 acc. to EN 1751
- Cycling test in class C<sub>mod</sub> acc. to EN 12101-8
- Certificate of constancy of performance No. 1391-CPR-XXXX/XXXX
- Declaration of Performance No. PM/SEDM-L/01/XX/X
- Hygienic assessment - Report No. 1.6/pos/19/19b

### Classification of Dampers

Supporting construction	Installation type	Classification
Horizontal or vertical smoke extraction ducts tested according to EN 1366-8 or EN 1366-9 <ul style="list-style-type: none"> <li>● into/onto the duct</li> </ul>	Damper installed into a duct or onto a duct with grille	EI120(V <sub>edw</sub> )S1000[H]C <sub>mod</sub> HOT400/30MAmulti
	Damper installed onto a duct without grille	EI90(V <sub>edw</sub> )S1000[H]C <sub>mod</sub> HOT400/30MAmulti
Standard low- and high-density rigid wall construction according to EN 1363-1 <ul style="list-style-type: none"> <li>● damper in the wall or shaft wall</li> <li>● 100 mm min. wall thickness</li> </ul>	Ablative Coated Batt	EI90(V <sub>edw</sub> )S1000[H]C <sub>mod</sub> HOT400/30MAmulti
	Mortar or gypsum	EI120(V <sub>edw</sub> )S1000[H]C <sub>mod</sub> HOT400/30MAmulti
Standard flexible wall construction, min. EI90. according to EN 1363-1 <ul style="list-style-type: none"> <li>● damper in the wall or shaft wall</li> <li>● 100 mm min. wall thickness</li> </ul>	Ablative Coated Batt	EI90(V <sub>edw</sub> )S1000[H]C <sub>mod</sub> HOT400/30MAmulti
	Mortar or gypsum	EI120(V <sub>edw</sub> )S1000[H]C <sub>mod</sub> HOT400/30MAmulti
Non-standard asymmetrical shaft wall construction, min. EI120, made of gypsum plasterboards (3 × 15 mm and 1 × 19 mm) with steel studs <ul style="list-style-type: none"> <li>● damper in the wall or shaft wall</li> <li>● 107 mm min. wall thickness</li> </ul>	Mortar or gypsum	EI90(V <sub>edw</sub> )S1000[H]C <sub>mod</sub> HOT400/30MAmulti EI120(V <sub>edw</sub> )S1000[H]C <sub>mod</sub> HOT400/30MAmulti
Standard low- and high-density rigid floor construction according to EN 1366-2 <ul style="list-style-type: none"> <li>● damper in the shaft floor</li> <li>● 150 mm min. wall thickness</li> </ul>	Mortar or gypsum	EI90(H <sub>od</sub> )S1000[H]C <sub>mod</sub> HOT400/30MAmulti
		EI120(H <sub>od</sub> )S1000[H]C <sub>mod</sub> HOT400/30MAmulti

### Working conditions

- Exact damper function is provided under the following conditions
  - maximum air velocity 12 m/s
  - underpressure max. -1000 Pa or overpressure max. 500 Pa
- Dampers are designed for installation in vertical or horizontal openings of fire separating constructions.
- The damper shall be installed only with the blade axes oriented horizontally.
- Dampers are designed for macroclimatic areas with mild climate according to EN IEC 60 721-3-3 ed.2., class 3K22. (Environment 3K22 is typically protected place with regulated temperature)
- Temperature in the place of installation is permitted to range from -30°C to +50°C.

**Smoke and heat removal system**

- In normal operation, SEDM-L dampers remain closed.
- If necessary, in the event of a fire, the SEDM-L dampers in the affected fire section will open completely so that the smoke can be removed.
- When the smoke and heat removal dampers are activated, the dampers used for air supply in the affected section open.
- The dampers used to supply air in the affected fire section are installed at the ground.
- The dampers are controlled from the central control system on the basis of signals, e.g. from smoke detectors.
- The use of cables with a certain fire resistance for the supply voltage ensures that the actuator is supplied even in the event of a fire.

**Ventilation system**

- During ventilation, SEDM-L dampers in the smoke and heat extraction system are controlled by a control system, it's possible to fully open, close or continuously control the flow.
- The SEDM-L dampers, which are used for air supply, remain closed during ventilation.

**Example of a ventilation device for forced smoke and heat removal**

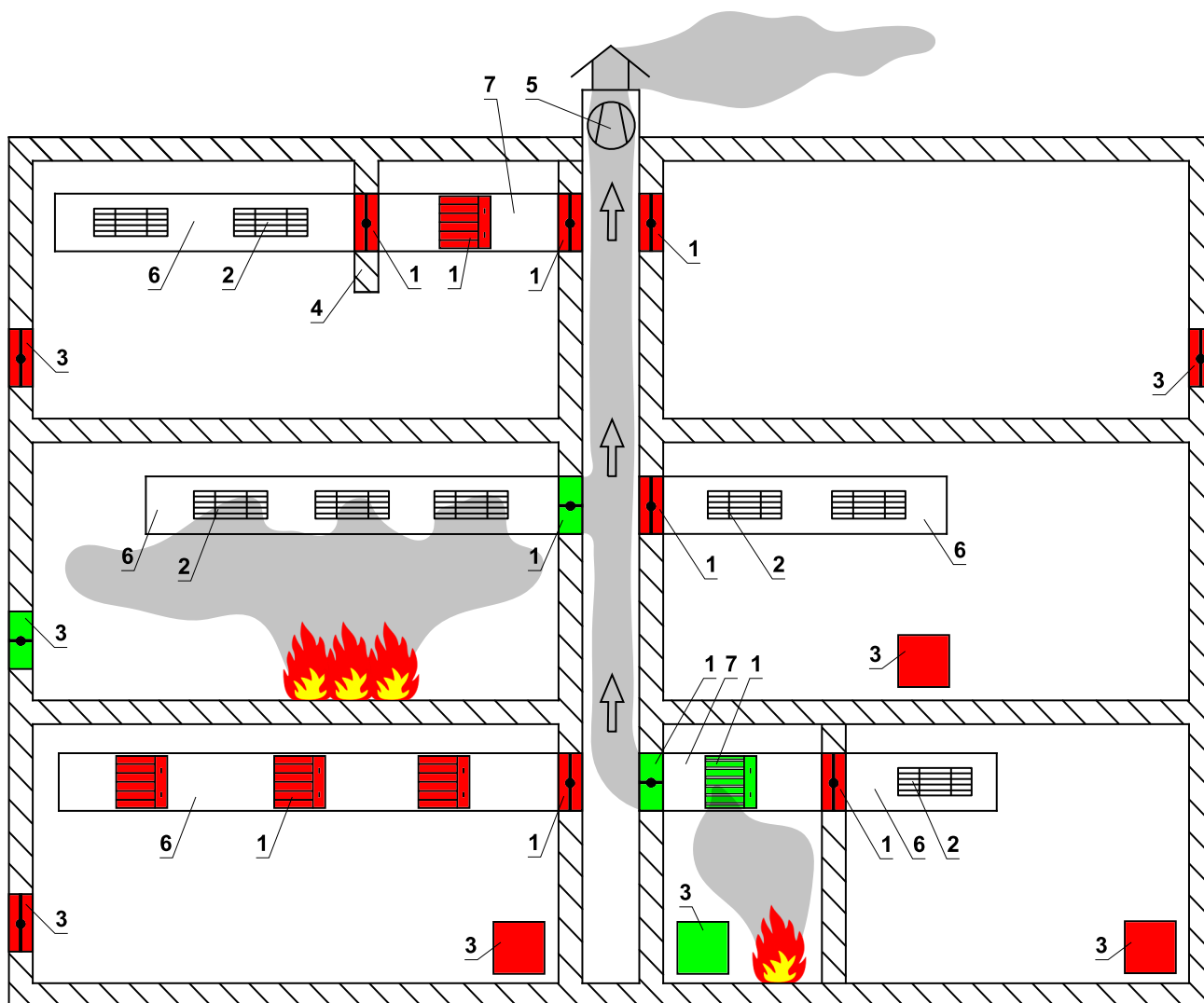

- 1 Multi compartment smoke control damper
- 2 Ventilation grille or damper for smoke and heat removal from one section
- 3 Air inlet
- 4 Smoke barrier
- 5 Fan for forced smoke and heat removal
- 6 Duct for smoke extraction from one section
- 7 Multi-section smoke extraction duct

## II. DESIGN

### Design with actuating mechanism

#### Design .44 and .54

- Belimo actuators are used for dampers, series BEN, BEE, BE for 230V AC resp. 24 V AC/DC actuators (universal 24V or 230V supply) are used for large size of dampers.
- After connection to the power supply voltage, the actuator moves the damper blade to the "OPEN" position or "CLOSED" (according to the corresponding connection, see wiring diagram). If the power supply is interrupted, the actuator stops at the current position. The signalling of the "OPEN" and "CLOSED" damper blade positions is ensured by two built-in fixed "potential-free" end- limit switches.
- The actuator for operating the damper blade is mounted in an insulated cover/box. It is accessible after removing the cover lid. The electrical connection of the actuator is made with a non-flammable cable (or a cable located in the adjoining cable duct), which passes through an opening made in the wall of the insulated cover/box when installing the damper or when connecting the actuator power cable. Cable penetrations must meet a minimum fire resistance of 30 minutes.

#### Design .65

- Belimo modulating actuators, BEN (BEE)-SR series for 24V AC/DC are specially designed for remote control of smoke control dampers. The position of the damper blade is adjustable by means of control voltage 0 (2)...10V DC.
- The signalling of the "OPEN" and "CLOSED" damper blade positions is ensured by two built-in fixed "potential-free" limit switches.
- The actuator for operating the damper blade is mounted in an insulated cover/box. It is accessible after removing the cover lid. The electrical connection of the actuator is made with non-flammable cables (or cables located in the adjoining cable duct), which pass through an opening made in the wall of the insulated cover when installing the damper or when connecting the power cables of the actuator. Cable penetrations must meet a minimum fire resistance of 30 minutes.

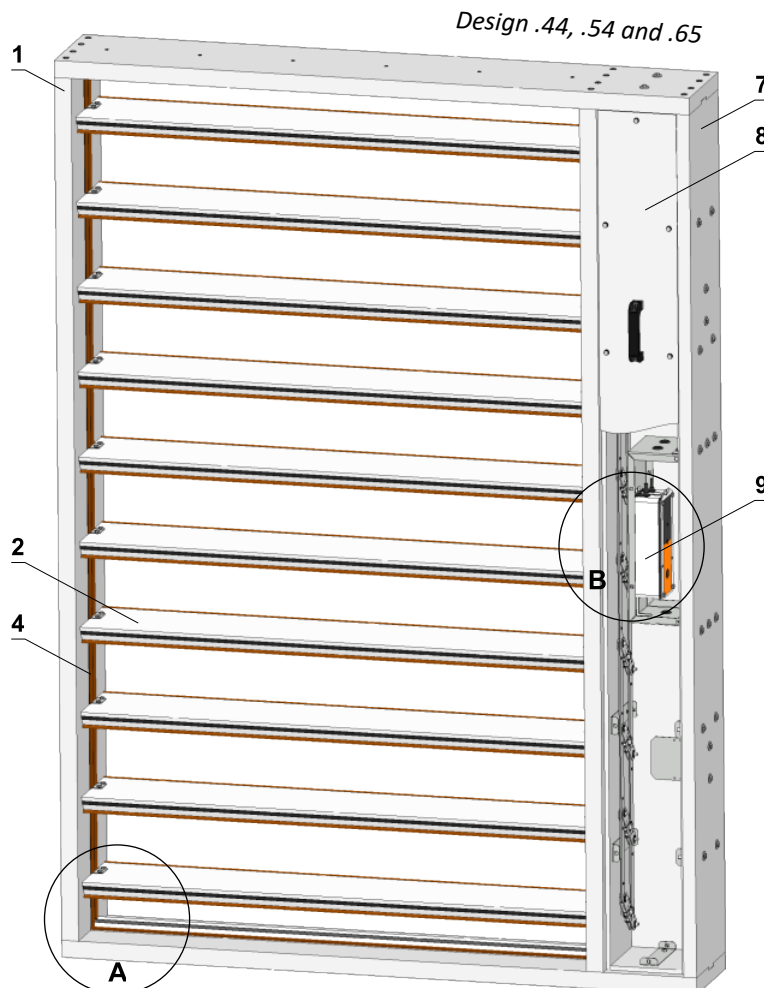
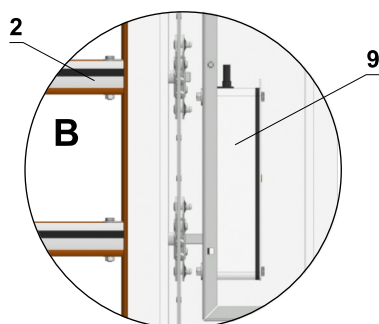
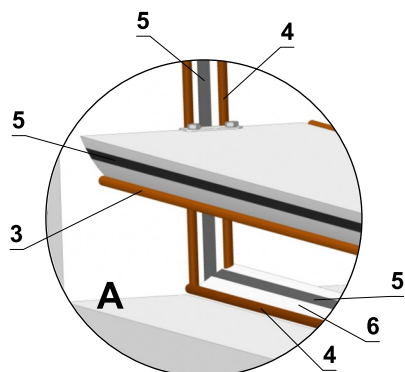

- |                           |                          |
|---------------------------|--------------------------|
| 1 Damper housing          | 6 Blade stop             |
| 2 Blades                  | 7 Actuator housing       |
| 3 Silicone blade seal     | 8 Actuator housing cover |
| 4 Internal silicone seal  | 9 Actuator               |
| 5 Fire-fighting foam tape |                          |

Actuator BELIMO BEN 24(-ST)

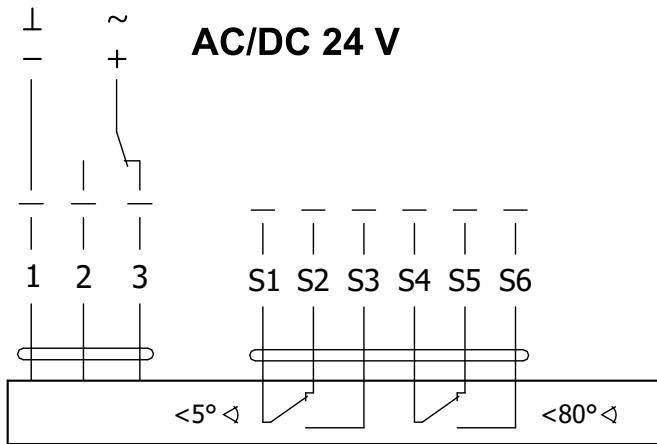

Actuator BELIMO BEN 24-SR

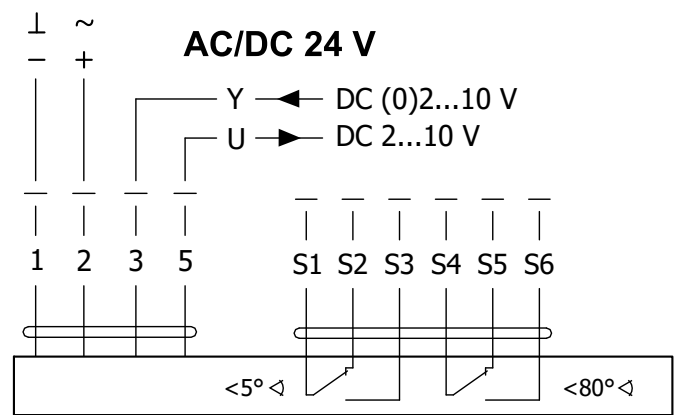

Actuator BELIMO BEN 230

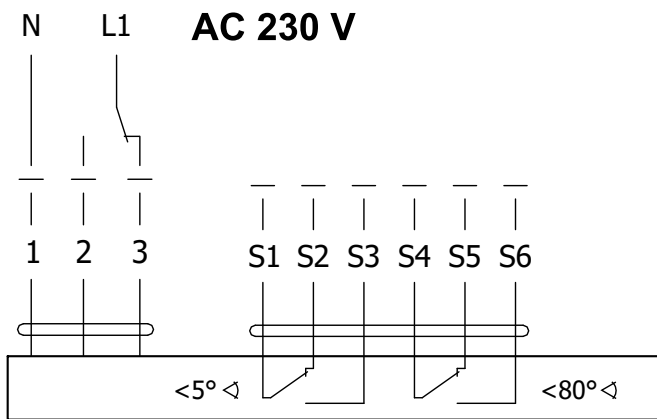

Actuator BELIMO BEN 24(-ST), BEN 24-SR, BEN 230

Actuator BELIMO - 15 Nm	BEN 24(-ST)	BEN 24-SR*	BEN 230
Power voltage	AC/DC 24 V 50/60Hz	AC/DC 24 V 50/60Hz	AC 230 V 50/60Hz
Power consumption - in operation - in the end position	3 W 0,1 W	3 W 0,3 W	4 W 0,4 W
Dimensioning	6 VA (I <sub>max</sub> 8,2 A @ 5 ms)	6,5 VA (I <sub>max</sub> 8.2 A @ 5 ms)	7 VA (I <sub>max</sub> 4 A @ 5 ms)
Protection class	III	III	II
Degree of protection		IP 54	
Adjustment time for 95°		< 30 s	
Ambient temperature Storage temperature		-30°C ... +55°C -40°C ... +80°C	
Connection - drive - auxiliary switch	Cable 1 m, 3 x 0,75 mm <sup>2</sup> Cable 1 m, 6 x 0,75 mm <sup>2</sup> (BEN 24-ST) with plug connectors	Cable 1 m, 4 x 0,75 mm <sup>2</sup> Cable 1 m, 6 x 0,75 mm <sup>2</sup>	Cable 1 m, 3 x 0,75 mm <sup>2</sup> Cable 1 m, 6 x 0,75 mm <sup>2</sup>

\* Only available for 24V and selected damper sizes

**Actuator BELIMO BEE 24(-ST)**

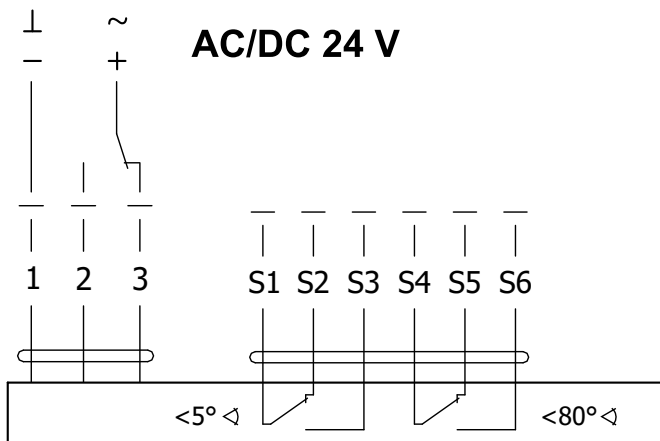

**Actuator BELIMO BEE 24-SR**

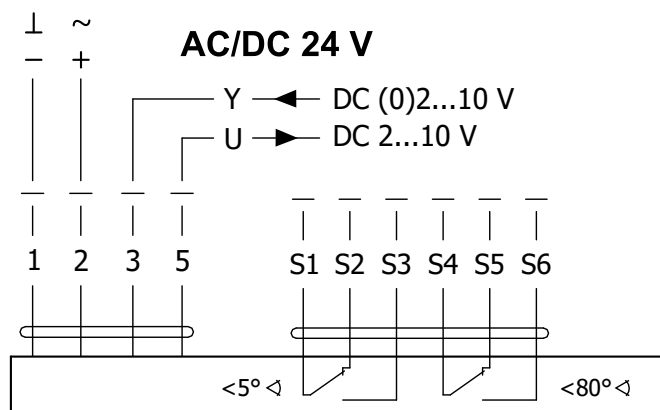

**Actuator BELIMO BEE 230**

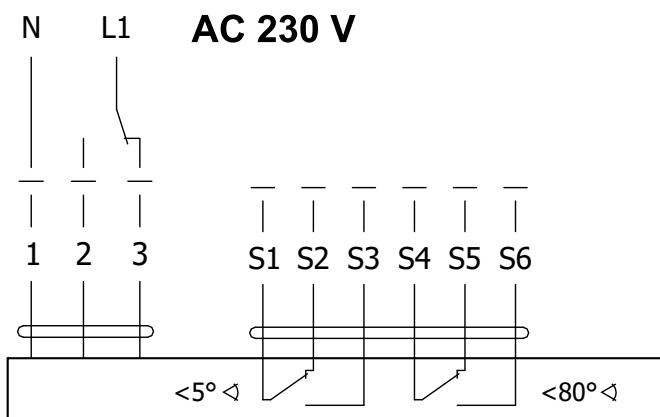

**Actuator BELIMO BEE 24(-ST), BEE 24-SR, BEE 230**

Actuator BELIMO - 25 Nm	BEE 24(-ST)	BEE 24-SR*	BEE 230
Power voltage	AC/DC 24 V 50/60Hz	AC/DC 24 V 50/60Hz	AC 230 V 50/60Hz
Power consumption - in operation - in the end position	2,5 W 0,1 W	3 W 0,3 W	3,5 W 0,4 W
Dimensioning	5 VA (I <sub>max</sub> 8,2 A @ 5 ms)	5,5 VA (I <sub>max</sub> 8.2 A @ 5 ms)	6 VA (I <sub>max</sub> 4 A @ 5 ms)
Protection class	III	III	II
Degree of protection		IP 54	
Adjustment time for 95°		< 60 s	
Ambient temperature Storage temperature		-30°C ... +55°C -40°C ... +80°C	
Connection - drive - auxiliary switch	Cable 1 m, 3 x 0,75 mm <sup>2</sup> Cable 1 m, 6 x 0,75 mm <sup>2</sup> (BEE 24-ST) with plug connectors	Cable 1 m, 4 x 0,75 mm <sup>2</sup> Cable 1 m, 6 x 0,75 mm <sup>2</sup>	Cable 1 m, 3 x 0,75 mm <sup>2</sup> Cable 1 m, 6 x 0,75 mm <sup>2</sup>

\* Only available for 24V and selected damper sizes

Actuator BELIMO BE 24-12(-ST)

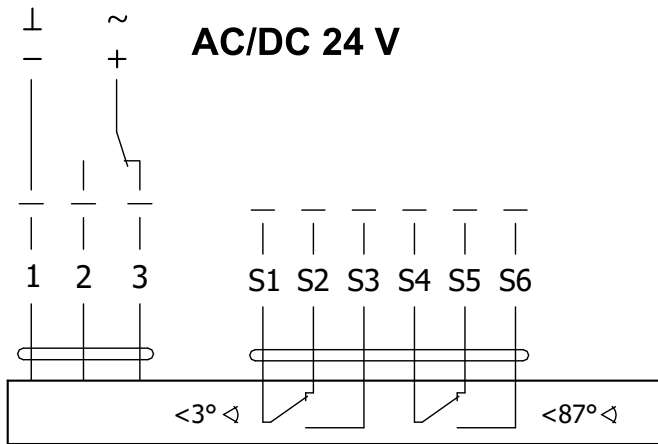

Actuator BELIMO BE 230-12

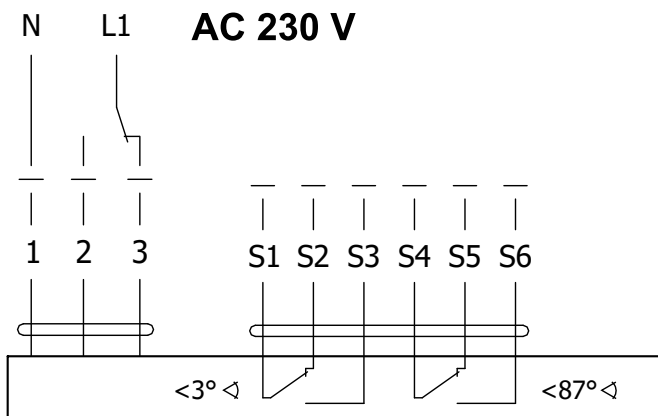

Actuator BELIMO BE 24-12(-ST), BE 230-12

Actuator BELIMO - 40 Nm	BE 24-12(-ST)	BE 230-12
Power voltage	AC/DC 24 V 50/60Hz	AC 230 V 50/60Hz
Power consumption - in operation - in the end position	12 W 0,5 W	8 W 0,5 W
Dimensioning	18 VA (I <sub>max</sub> 8,2 A @ 5 ms)	15 VA (I <sub>max</sub> 7.9 A @ 5 ms)
Protection class	III	II
Degree of protection	IP 54	
Adjustment time for 95°	< 60 s	
Ambient temperature	-30°C ... +55°C	
Storage temperature	-40°C ... +80°C	
Connection - drive - auxiliary switch	Cable 1 m, 3 x 0,75 mm <sup>2</sup> Cable 1 m, 6 x 0,75 mm <sup>2</sup> (BE 24-ST) with plug connectors	

### III.DIMENSIONS

#### SEDM-L without flange and cover grille

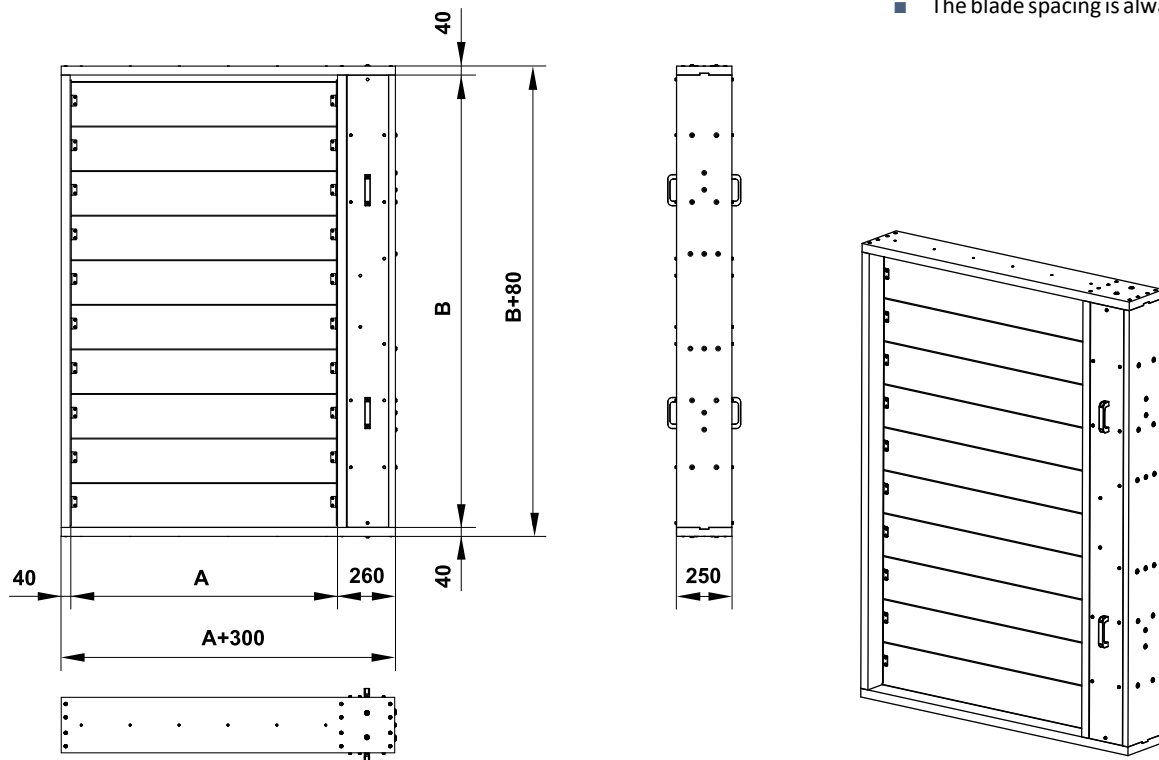

#### SEDM-L with flange and cover grille over blades

\* External dimension of the grille

- The blade spacing is always 200mm
- For a detail of the cover grille filling, → see page 11

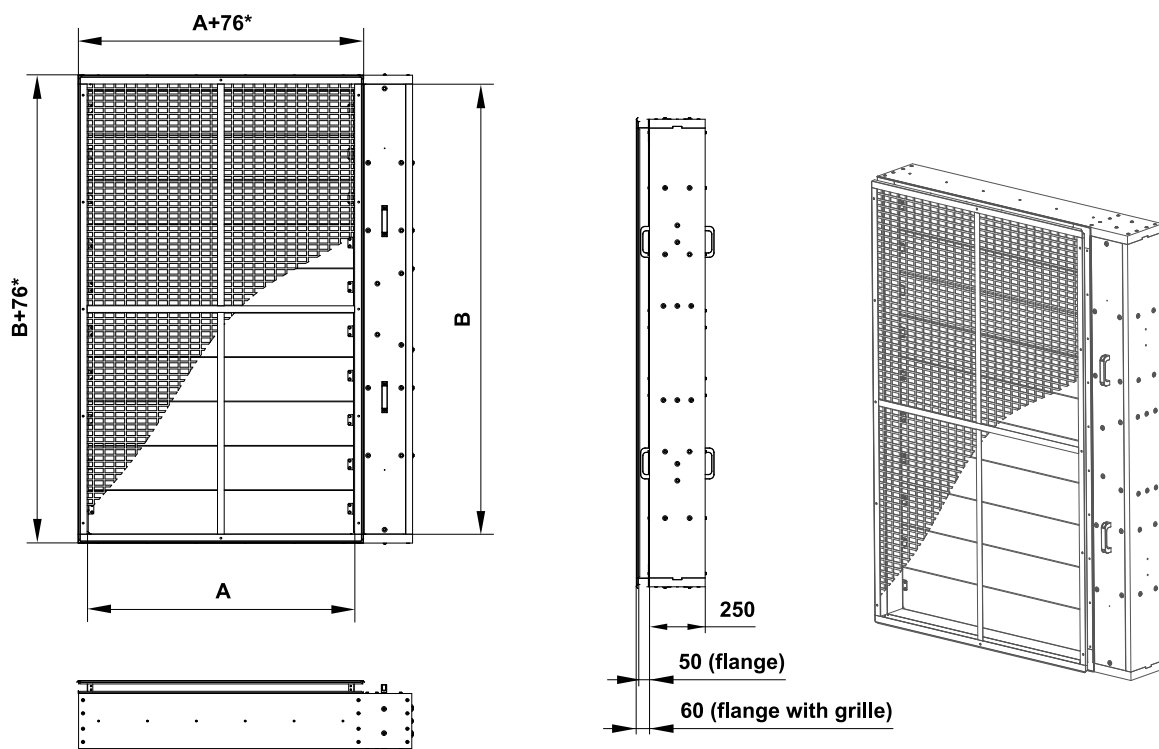

SEDM-L with flange and cover grille over damper

\* External dimension of the grille

- The blade spacing is always 200mm
- For a detail of the cover grille filling, → see page 11

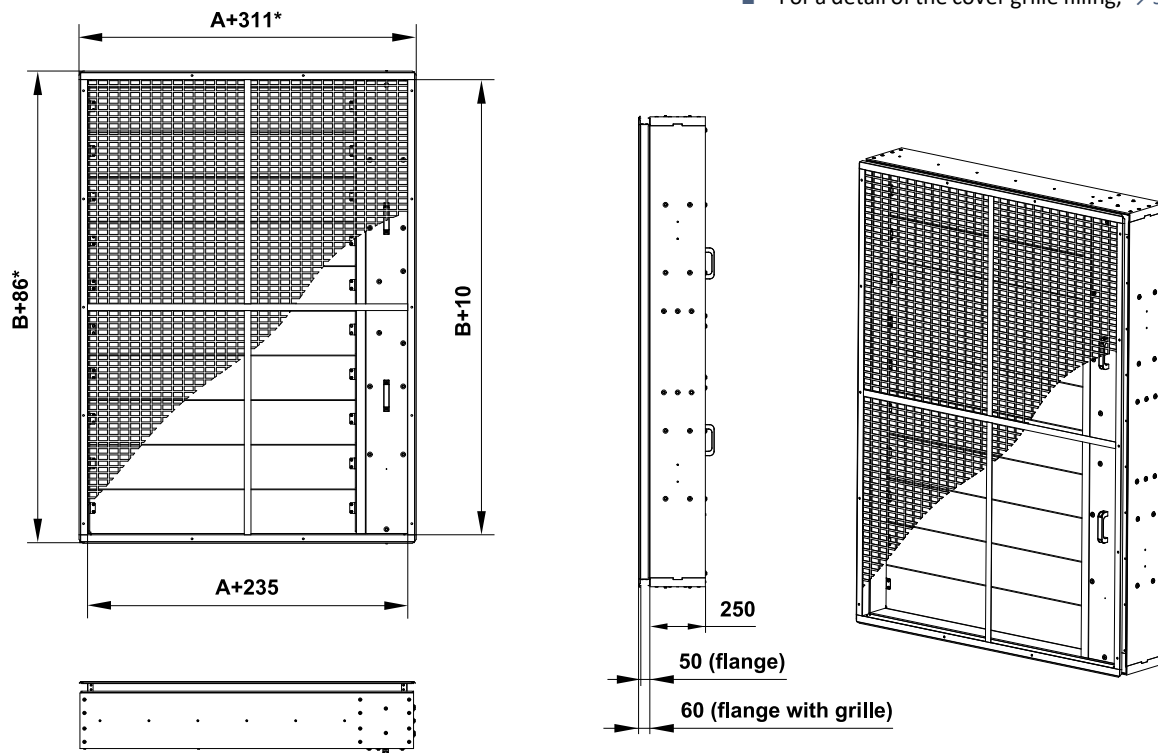

Flange (2 types)

Flange over blades

Flange over damper

- Oval holes in the corners are used to connect the duct. Other holes are technological.

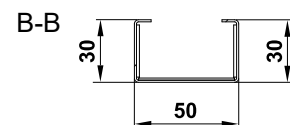
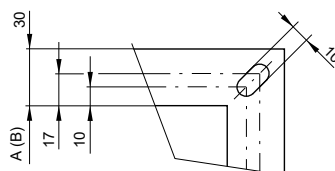
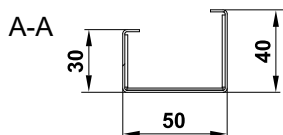
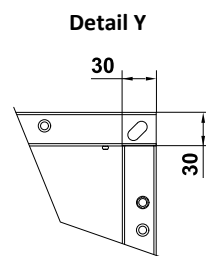
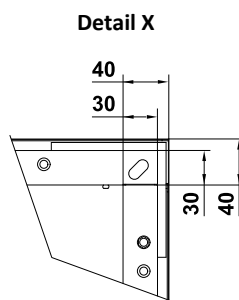
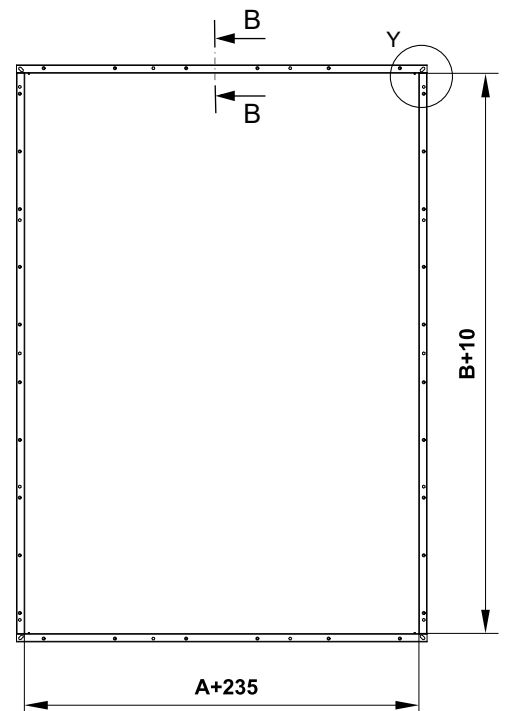
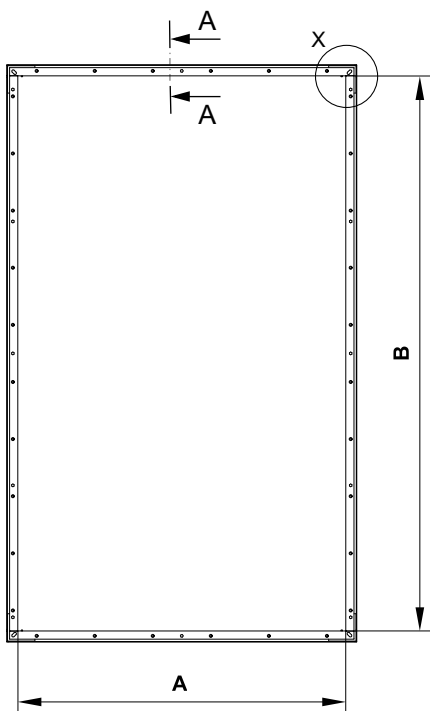

**Cover grille KMM**

- The grilles type KMM (TPM 002/96) can be used to close smoke control dampers.
- Maximum size KMM can we supply is 2400x2400mm.
- Free area value for KMM is 78%.



Technical parameters

A x B [mm]	Number of blades	Free area S <sub>f</sub> [m <sup>2</sup> ]	Weight SEDM-L [kg]	Weight flange over blades [kg]	Weight flange over damper [kg]	Weight grille over blades [kg]	Weight grille over damper [kg]	Actuating mechanism type
200	2	0,0537	36,5	1,8	2	0,9	1,4	BELIMO BEN (15 N.m)
250		0,0682	38,2	1,9	2,1	1	1,5	
300		0,0827	39,9	2	2,2	1,1	1,6	
350		0,0972	41,6	2,1	2,3	1,2	1,7	
400		0,1117	43,3	2,2	2,4	1,3	1,8	
450		0,1262	45	2,3	2,5	1,4	1,9	
500		0,1407	46,6	2,4	2,6	1,5	2	
550		0,1552	48,3	2,5	2,7	1,6	2,1	
600		0,1697	50	2,6	2,7	1,7	2,2	
650		0,1842	51,7	2,7	2,8	1,8	2,3	
700 x 430		0,1987	53,4	2,8	2,9	1,9	2,4	
750		0,2132	56,7	2,9	3	2	2,5	
800		0,2277	58,4	2,9	3,1	2,1	2,6	
850		0,2422	60,1	3	3,2	2,2	2,7	
900		0,2567	61,8	3,1	3,3	2,3	2,8	
950		0,2712	63,4	3,2	3,4	2,4	3	
1000		0,2857	65,1	3,4	3,5	2,5	3,1	
1050		0,3002	66,8	3,5	3,6	2,6	3,2	
1100		0,3147	68,5	3,6	3,7	2,7	3,3	
1150		0,3292	70,2	3,7	3,8	2,8	3,4	
1200	0,3437	71,9	3,8	3,9	3	3,5		
200	3	0,0833	47,8	2,2	2,4	1,2	1,8	BELIMO BEN (15 N.m)
250		0,1058	49,9	2,3	2,5	1,3	1,9	
300		0,1283	51,9	2,4	2,6	1,4	2	
350		0,1508	53,9	2,5	2,7	1,6	2,2	
400		0,1733	56	2,6	2,7	1,7	2,3	
450		0,1958	58	2,7	2,8	1,8	2,4	
500		0,2183	60,1	2,8	2,9	1,9	2,5	
550		0,2408	62,2	2,9	3	2	2,7	
600		0,2633	64,2	3	3,1	2,2	2,8	
650		0,2858	67,8	3,1	3,2	2,3	2,9	
700 x 630		0,3083	69,8	3,2	3,3	2,4	3	
750		0,3308	71,9	3,3	3,4	2,5	3,2	
800		0,3533	74	3,3	3,5	2,7	3,4	
850		0,3758	76	3,4	3,6	2,8	3,5	
900		0,3983	78	3,5	3,7	2,9	3,6	
950		0,4208	80,3	3,6	3,8	3	3,8	
1000		0,4433	82,3	3,7	3,9	3,4	3,9	
1050		0,4658	84,4	3,9	3,9	3,5	4	
1100		0,4883	86,4	4	4	3,6	4,1	
1150		0,5108	88,5	4,1	4,1	3,8	4,3	
1200	0,5333	90,5	4,2	4,2	3,9	4,4		
200	4	0,1129	59,4	2,6	2,7	1,5	2,2	BELIMO BEN (15 N.m)
250		0,1434	61,8	2,7	2,8	1,6	2,3	
300		0,1739	64,2	2,8	2,9	1,8	2,5	
350		0,2044	66,6	2,9	3	1,9	2,6	
400		0,2349	69	3	3,1	2,1	2,8	
450		0,2654	71,4	3,1	3,2	2,2	2,9	
500		0,2959	73,8	3,2	3,3	2,4	3,1	
550		0,3264	77,7	3,3	3,4	2,5	3,2	
600		0,3569	80,1	3,4	3,5	2,7	3,4	
650		0,3874	82,6	3,5	3,6	2,8	3,5	
700 x 830		0,4179	85,2	3,6	3,7	2,9	3,7	
750		0,4484	87,6	3,7	3,8	3,1	3,8	
800		0,4789	90	3,7	3,9	3,2	4,1	
850		0,5094	92,4	3,8	3,9	3,4	4,3	
900		0,5399	94,8	3,9	4	3,5	4,4	
950		0,5704	101	4	4,1	3,7	4,6	
1000		0,6009	103,6	4,2	4,2	4,1	4,7	
1050		0,6314	106,2	4,3	4,3	4,3	4,9	
1100		0,6619	108,8	4,4	4,4	4,4	5	
1150		0,6924	111,3	4,5	4,5	4,6	5,2	
1200	0,7229	114	4,6	4,6	4,7	5,3		
								BELIMO BEE (25 N.m)

A x B [mm]	Number of blades	Free area S <sub>f</sub> [m <sup>2</sup> ]	Weight SEDM-L [kg]	Weight flange over blades [kg]	Weight flange over damper [kg]	Weight grille over blades [kg]	Weight grille over damper [kg]	Actuating mechanism type
200	5	0,1425	70,8	3	3,1	1,8	2,6	BELIMO BEN (15 N.m)
250		0,1810	73,5	3,1	3,2	1,9	2,9	
300		0,2195	76,3	3,2	3,3	2,1	3,1	
350		0,2580	79	3,3	3,4	2,3	3,3	
400		0,2965	81,8	3,4	3,5	2,4	3,5	
450		0,3350	86,1	3,5	3,6	2,6	3,7	
500		0,3735	89,1	3,5	3,7	3	3,9	
550		0,4120	91,8	3,6	3,8	3,2	4,1	
600		0,4505	94,6	3,7	3,9	3,3	4,3	
650		0,4890	97,3	3,8	3,9	3,5	4,4	
700 x 1030		0,5275	100,1	3,9	4,0	3,7	4,6	BELIMO BEE (25 N.m)
750		0,5660	106	4	4,1	3,9	4,8	
800		0,6045	109	4,1	4,2	4,1	5,4	
850		0,6430	111,9	4,2	4,3	4,3	5,6	
900		0,6815	114,8	4,3	4,4	4,5	5,8	
950		0,7200	117,8	4,4	4,5	4,7	5,9	
1000		0,7585	122,5	4,5	4,6	5,2	6,1	
1050		0,7970	125,4	4,6	4,7	5,4	6,3	
1100		0,8355	128,3	4,7	4,8	5,6	6,5	BELIMO BE (40 N.m)
1150		0,8740	131,3	4,8	4,9	5,8	6,7	
1200	0,9125	134,2	4,9	5	6	6,9		
200	6	0,1721	82	3,4	3,5	2,1	3,1	BELIMO BEN (15 N.m)
250		0,2186	85,1	3,5	3,6	2,3	3,4	
300		0,2651	88,2	3,6	3,7	2,4	3,6	
350		0,3116	91,5	3,7	3,8	2,6	3,8	
400		0,3581	94,6	3,8	3,9	2,8	4	
450		0,4046	99,3	3,9	4	3,2	4,2	
500		0,4511	102,4	4	4	3,4	4,4	
550		0,4976	105,5	4,1	4,1	3,6	4,6	BELIMO BEE (25 N.m)
600		0,5441	108,6	4,2	4,2	3,8	4,9	
650		0,5906	114,7	4,2	4,3	4	5,1	
700 x 1230		0,6371	118	4,3	4,4	4,2	5,3	
750		0,6836	121,3	4,5	4,5	4,5	5,5	
800		0,7301	124,5	4,5	4,6	4,7	6,1	
850		0,7766	129,6	4,6	4,7	4,9	6,3	
900		0,8231	132,9	4,7	4,8	5,1	6,6	
950		0,8696	136,2	4,8	4,9	5,3	6,8	
1000		0,9161	139,5	4,9	5	5,9	7	BELIMO BE (40 N.m)
1050		0,9626	142,8	5	5,1	6,2	7,2	
1100		1,0091	146	5,1	5,2	6,4	7,4	
1150		1,0556	149,3	5,3	5,2	6,6	7,6	
1200	1,1021	152,7	5,4	5,3	6,8	7,8		
200	7	0,2017	93,3	3,7	3,9	2,3	3,5	BELIMO BEN (15 N.m)
250		0,2562	96,8	3,8	3,9	2,6	3,8	
300		0,3107	100,5	3,9	4	2,8	4	
350		0,3652	105,5	4	4,1	3,1	4,2	
400		0,4197	109	4,1	4,2	3,4	4,5	
450		0,4742	112,4	4,2	4,3	3,6	4,7	
500		0,5287	115,9	4,3	4,4	3,8	5	BELIMO BEE (25 N.m)
550		0,5832	122,1	4,4	4,5	4,1	5,2	
600		0,6377	125,7	4,5	4,6	4,3	5,4	
650		0,6922	129,3	4,6	4,7	4,5	5,7	
700 x 1430		0,7467	133	4,7	4,8	4,8	5,9	
750		0,8012	138,4	4,8	4,9	5	6,1	
800		0,8557	142,1	4,9	5	5,2	6,9	
850		0,9102	145,7	5	5,1	5,5	7,1	
900		0,9647	149,3	5,1	5,1	5,7	7,3	
950		1,0192	152,9	5,2	5,2	5,9	7,6	BELIMO BE (40 N.m)
1000		1,0737	156,6	5,3	5,3	6,7	7,8	
1050		1,1282	160,2	5,4	5,4	6,9	8	
1100		1,1827	163,9	5,5	5,5	7,1	8,3	
1150		1,2372	167,5	5,6	5,6	7,4	8,5	
1200	1,2917	171,2	5,7	5,7	7,6	8,7		

A x B [mm]	Number of blades	Free area S <sub>f</sub> [m <sup>2</sup> ]	Weight SEDM-L [kg]	Weight flange over blades [kg]	Weight flange over damper [kg]	Weight grille over blades [kg]	Weight grille over damper [kg]	Actuating mechanism type
200	8	0,2313	104,9	4,2	4,2	2,6	3,9	BELIMO BEE (25 N.m)
250		0,2938	108,7	4,3	4,3	2,9	4,2	
300		0,3563	112,5	4,4	4,4	3,1	4,5	
350		0,4188	117,9	4,4	4,5	3,5	4,7	
400		0,4813	121,7	4,5	4,6	3,7	5	
450		0,5438	125,6	4,7	4,7	4	5,2	
500		0,6063	129,4	4,7	4,8	4,3	5,5	
550		0,6688	136	4,8	4,9	4,5	5,8	
600		0,7313	140	4,9	5	4,8	6	
650		0,7938	145,8	5	5,1	5	6,3	
700 x 1630		0,8563	149,7	5,1	5,2	5,3	6,5	
750		0,9188	153,7	5,2	5,2	5,5	6,8	
800		0,9813	157,7	5,3	5,3	5,8	7,6	
850		1,0438	161,7	5,4	5,4	6,1	7,9	
900		1,1063	165,7	5,5	5,5	6,3	8,1	
950		1,1688	169,7	5,6	5,6	6,6	8,4	
1000	1,2313	173,7	5,7	5,7	7,4	8,7		
1050	1,2938	177,7	5,8	5,8	7,7	8,9		
1100	1,3563	181,7	5,9	5,9	7,9	9,2		
1150	1,4188	185,7	6	6	8,2	9,4		
1200	1,4813	189,7	6,1	6,1	8,4	9,7		
200	9	0,2609	116	4,6	4,6	2,9	4,3	BELIMO BEE (25 N.m)
250		0,3314	120,1	4,7	4,7	3,2	4,6	
300		0,4019	124,3	4,8	4,8	3,6	4,9	
350		0,4724	130,1	4,9	4,9	3,8	5,2	
400		0,5429	134,2	5	5	4,1	5,5	
450		0,6134	138,4	5,1	5,1	4,4	5,8	
500		0,6839	142,6	5,1	5,2	4,7	6	
550		0,7544	149,7	5,3	5,2	5	6,3	
600		0,8249	155,8	5,4	5,3	5,3	6,6	
650		0,8954	160,1	5,4	5,4	5,5	6,9	
700 x 1830		0,9659	164,5	5,5	5,5	5,8	7,2	
750		1,0364	168,8	5,6	5,6	6,1	7,5	
800		1,1069	173,2	5,7	5,7	6,4	8,4	
850		1,1774	177,5	5,8	5,8	6,7	8,7	
900		1,2479	181,9	5,9	5,9	6,9	8,9	
950		1,3184	186,2	6	6	7,2	9,2	
1000	1,3889	190,5	6,1	6,1	8,1	9,5		
1050	1,4594	194,9	6,2	6,2	8,4	9,8		
1100	1,5299	199,2	6,3	6,3	8,7	10,1		
1150	1,6004	203,6	6,4	6,4	9	10,4		
1200	1,6709	207,9	6,5	6,4	9,3	10,6		
200	10	0,2905	127	4,9	5	3,2	4,7	BELIMO BEE (25 N.m)
250		0,3690	131,6	5	5,1	3,6	5,1	
300		0,4475	137,7	5,1	5,2	3,9	5,4	
350		0,5260	142,2	5,2	5,2	4,2	5,7	
400		0,6045	146,8	5,3	5,3	4,5	6	
450		0,6830	151,2	5,4	5,4	4,8	6,3	
500		0,7615	157,6	5,5	5,5	5,1	6,6	
550		0,8400	165,1	5,6	5,6	5,4	6,9	
600		0,9185	169,8	5,7	5,7	5,7	7,2	
650		0,9970	174,5	5,8	5,8	6	7,5	
700 x 2030		1,0755	179,2	5,9	5,9	6,3	7,8	
750		1,1540	183,9	6	6	6,6	8,1	
800		1,2325	188,6	6,1	6,1	7	9,1	
850		1,3110	193,3	6,2	6,2	7,3	9,4	
900		1,3895	198	6,3	6,3	7,6	9,7	
950		1,4680	202,7	6,4	6,3	7,9	10	
1000	1,5465	207,4	6,5	6,4	8,9	10,4		
1050	1,6250	212,1	6,6	6,5	9,2	10,7		
1100	1,7035	216,8	6,7	6,6	9,5	11		
1150	1,7820	221,5	6,8	6,7	9,8	11,3		
1200	1,8605	226,2	6,9	6,8	10,1	11,6		
200	10	0,2905	127	4,9	5	3,2	4,7	BELIMO BE (40 N.m)
250		0,3690	131,6	5	5,1	3,6	5,1	
300		0,4475	137,7	5,1	5,2	3,9	5,4	
350		0,5260	142,2	5,2	5,2	4,2	5,7	
400		0,6045	146,8	5,3	5,3	4,5	6	
450		0,6830	151,2	5,4	5,4	4,8	6,3	
500		0,7615	157,6	5,5	5,5	5,1	6,6	
550		0,8400	165,1	5,6	5,6	5,4	6,9	
600		0,9185	169,8	5,7	5,7	5,7	7,2	
650		0,9970	174,5	5,8	5,8	6	7,5	
700 x 2030		1,0755	179,2	5,9	5,9	6,3	7,8	
750		1,1540	183,9	6	6	6,6	8,1	
800		1,2325	188,6	6,1	6,1	7	9,1	
850		1,3110	193,3	6,2	6,2	7,3	9,4	
900		1,3895	198	6,3	6,3	7,6	9,7	
950		1,4680	202,7	6,4	6,3	7,9	10	
1000	1,5465	207,4	6,5	6,4	8,9	10,4		
1050	1,6250	212,1	6,6	6,5	9,2	10,7		
1100	1,7035	216,8	6,7	6,6	9,5	11		
1150	1,7820	221,5	6,8	6,7	9,8	11,3		
1200	1,8605	226,2	6,9	6,8	10,1	11,6		

## IV. INSTALLATION

### Placement and installation

- Dampers are designed to remove heat and combustion products (e.g. smoke) from fire compartments
- Dampers are suitable for installation in vertical and horizontal position passages of fire separating constructions. The damper installation procedures must be done so that all load transfer from the fire separating constructions to the damper is absolutely excluded.
- Following air-conditioning duct must be suspended or supported so that all load transfer from the following duct to the damper flange is absolutely excluded.
- The gap between the installed damper and the fire separating construction must be perfectly filled with approved material.
- The dampers are suitable for installation into/onto smoke extraction ducts, tested and certified according to EN 1366-8, → see page 32
- After installing the damper, the damper blades must only be opened, or closed by operation of the actuator only.
- The distance between the damper and the construction (wall, ceiling) must be 75 mm at the minimum, according to EN 1366-2. If two or more dampers are to be installed in one fire separating construction, the distance between adjacent dampers must be 200 mm at the minimum, according to EN 1366-10.
- To provide the necessary space for access to the control device, it is recommended that other objects be at least 350 mm away from the control parts of the damper.

#### Minimum distance between the dampers and the construction

- minimum distance 200 mm between dampers, according to EN 1366-10
- minimum distance 75 mm between damper and construction (wall/ceiling), according to EN 1366-10

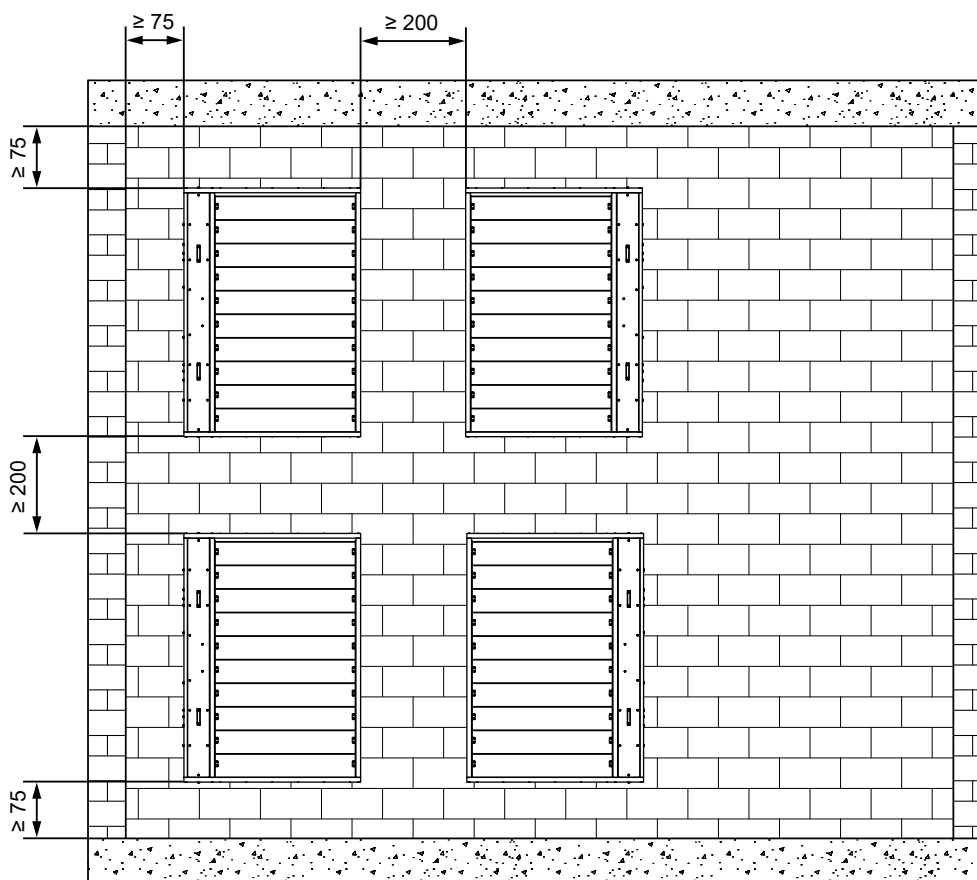

Recommended construction openings

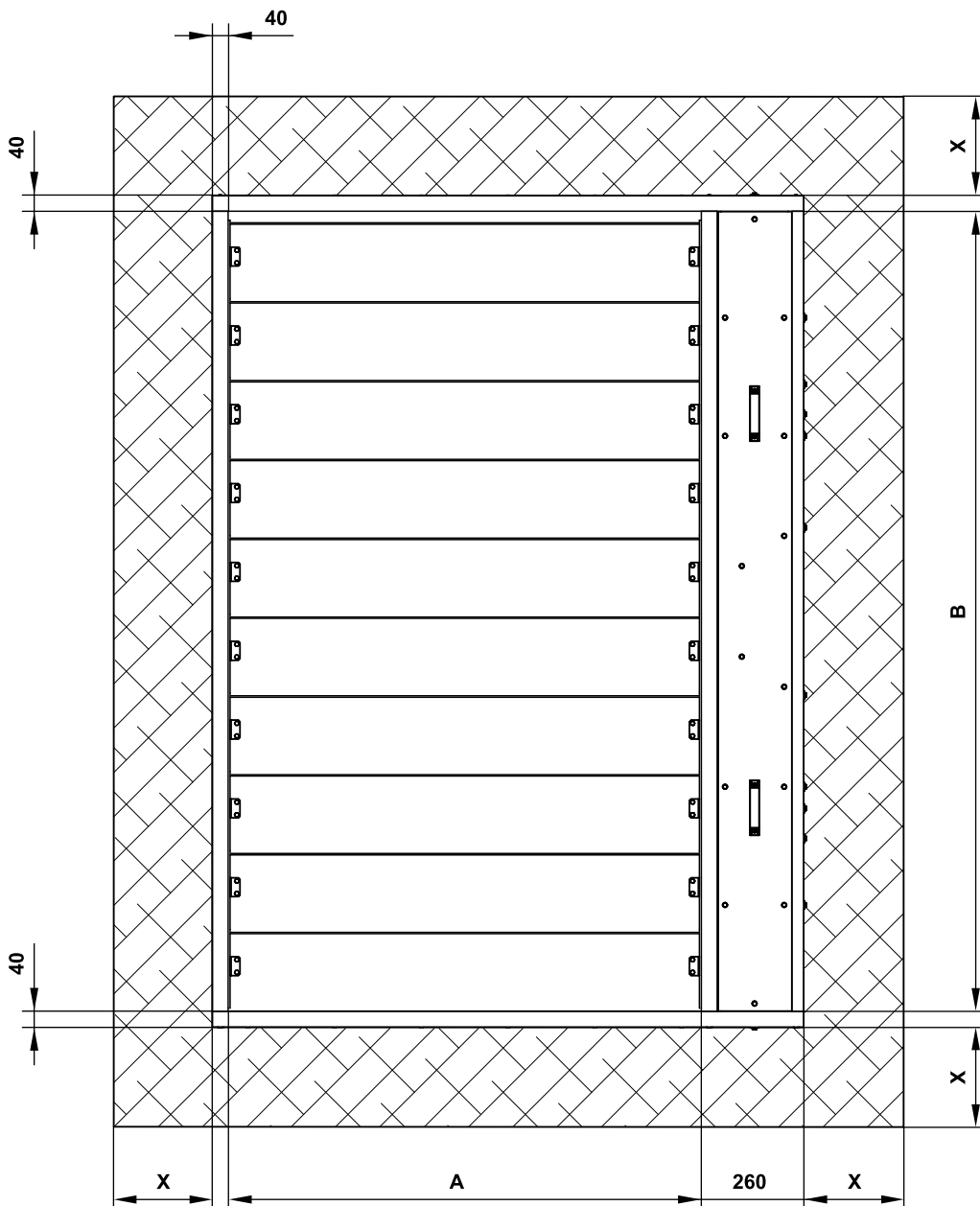

**Mortar or gypsum, damper in solid/ceiling/shaft wall construction**

- x = min. 50 mm
- x = max. 150 mm

**Mortar or gypsum, damper in gypsum wall construction**

- x = 50 mm<sup>+10/-0</sup> for max. fire resistance of the installation EI 120 S
- x = min. 50 mm for max. fire resistance of the installation EI 90 S
- x = max. 150 mm for max. fire resistance of the installation EI 90 S

**Ablative Coated Batt**

- x = 200 mm<sup>+0/-10</sup> for max. fire resistance of the installation EI 120 S
- x = min. 40 mm for max. fire resistance of the installation EI 90 S
- x = max. 230 mm for max. fire resistance of the installation EI 90 S

## Transport of the damper to the installation place and the installation procedure

- Transport the damper to the installation site in the transport packaging. Pay attention to the appropriate length of the forks of the forklift /handling equipment/ to avoid breaking of wooden planks, consequently damaging the damper's blades.
- Smaller dimensions can be transported, handled and installed into the builders work opening manually, for dimensions where a handling insert is included in the delivery, it is recommended to use a suitable handling tools and machines, e.g. a forklift.

### Damper handling when installed in the mounting hole

1. Place the damper in a vertical position. Do not remove the transport pacers and corners !



2. Place handling inserts between the top blade and the damper housing.

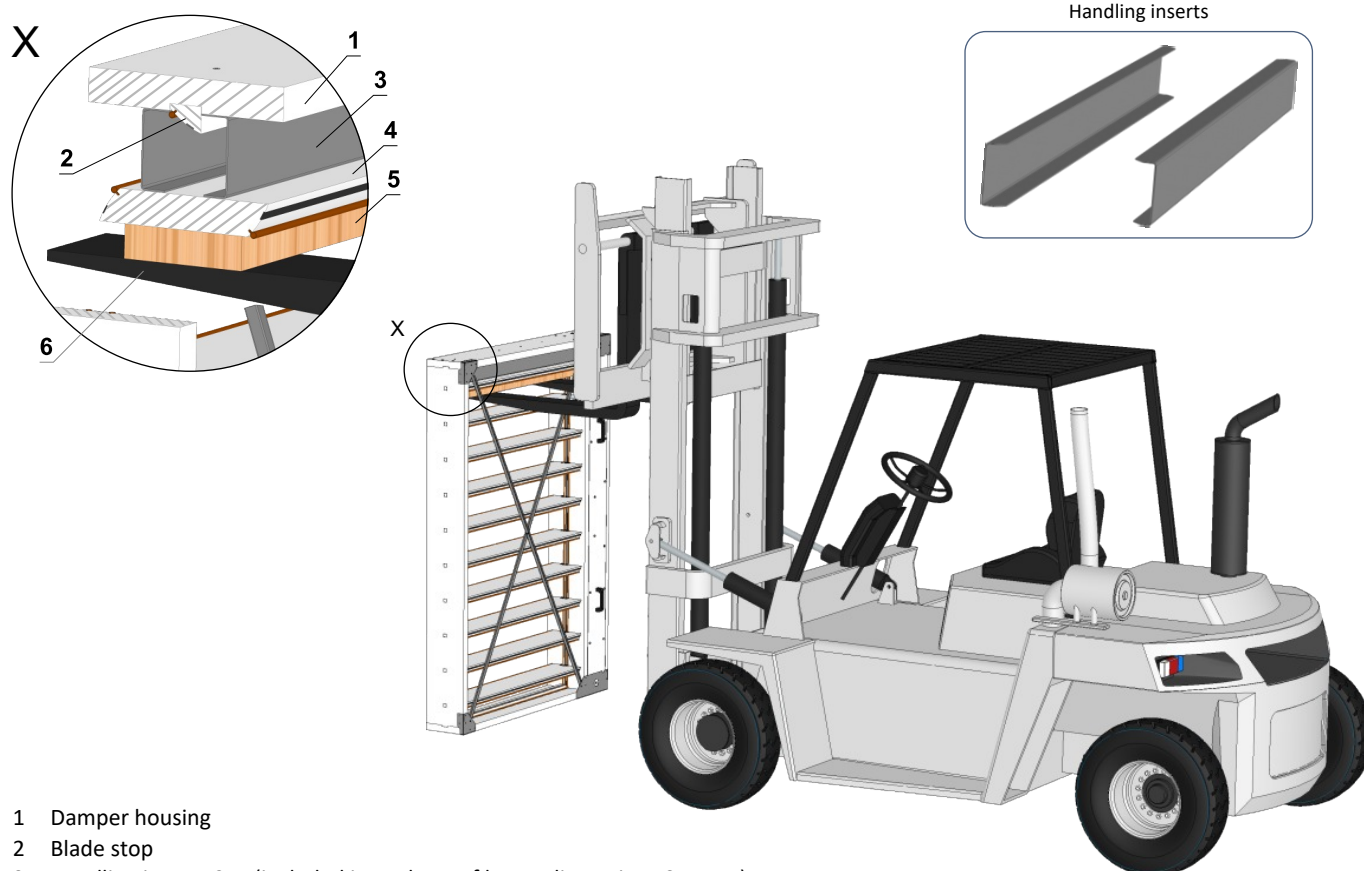

- 1 Damper housing
- 2 Blade stop
- 3 Handling inserts 2pc (included in package of larger dimensions SEDM-L)
- 4 Blade
- 5 Board - thickness min. 25mm (not included)
- 6 Forks

3. Drive the forklift under the highest blade. It's necessary to put a board between the blade and the fork along the blade's entire length so that the blade is not damaged when the damper is raised.

4. Place the damper in the installation hole.



5. After installing the damper and possibly hardening the plaster/mortar, remove the transport struts and corners.



6. Ways of placing the flange on the damper (2 types of flanges)

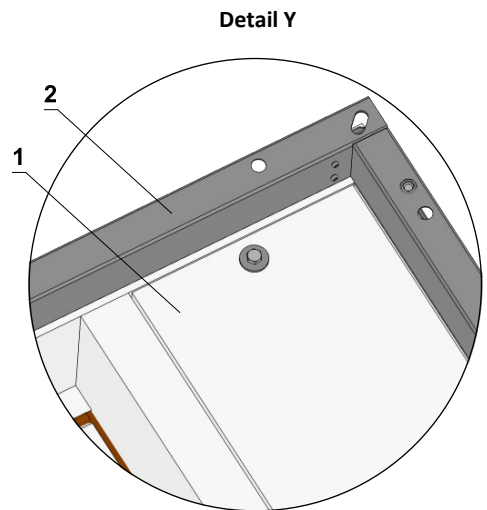
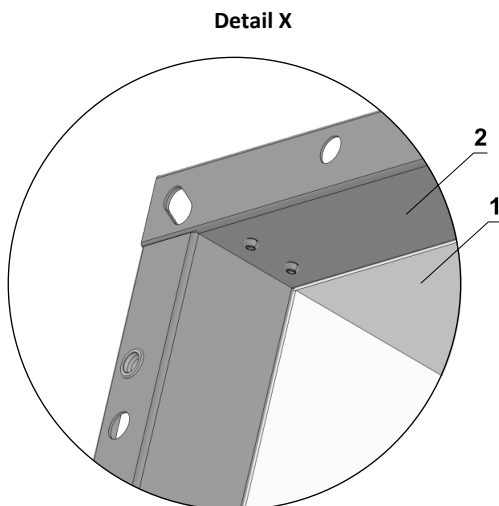
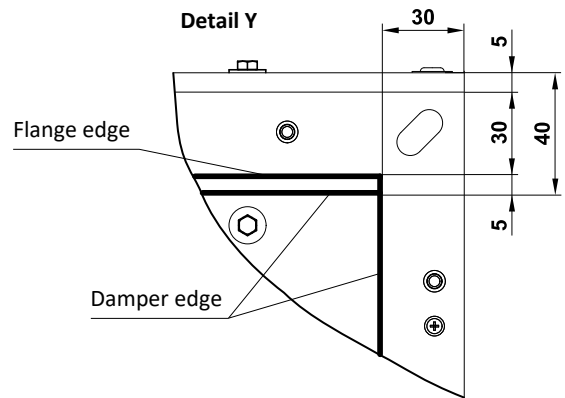
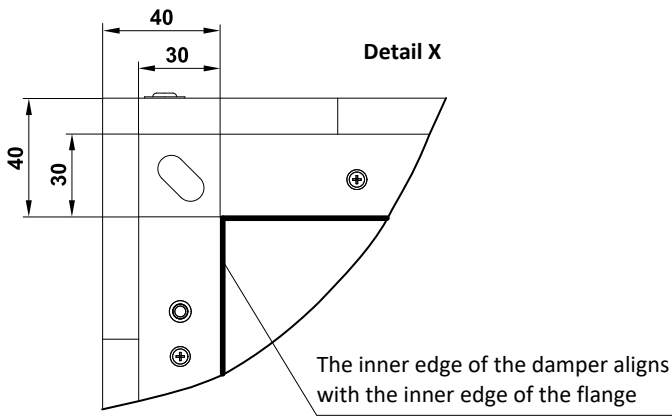
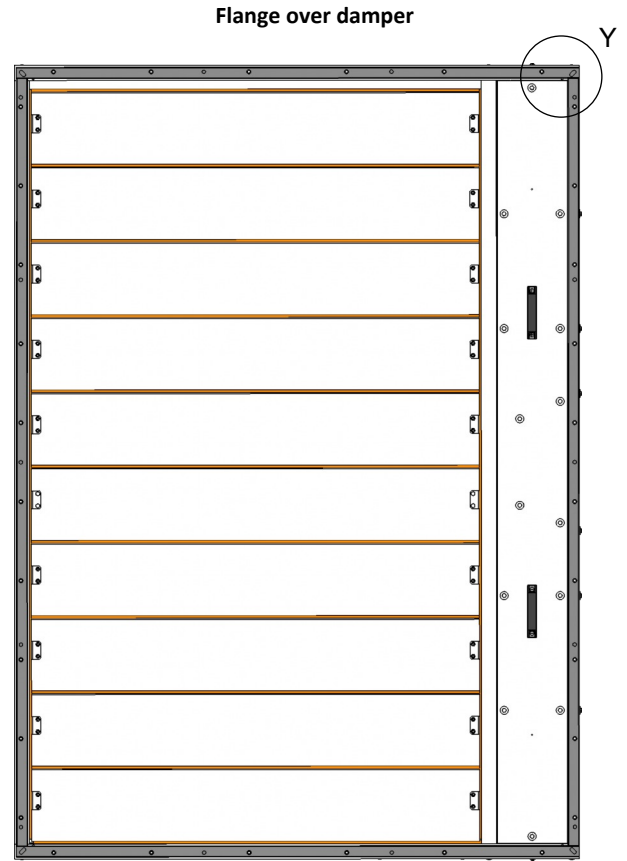
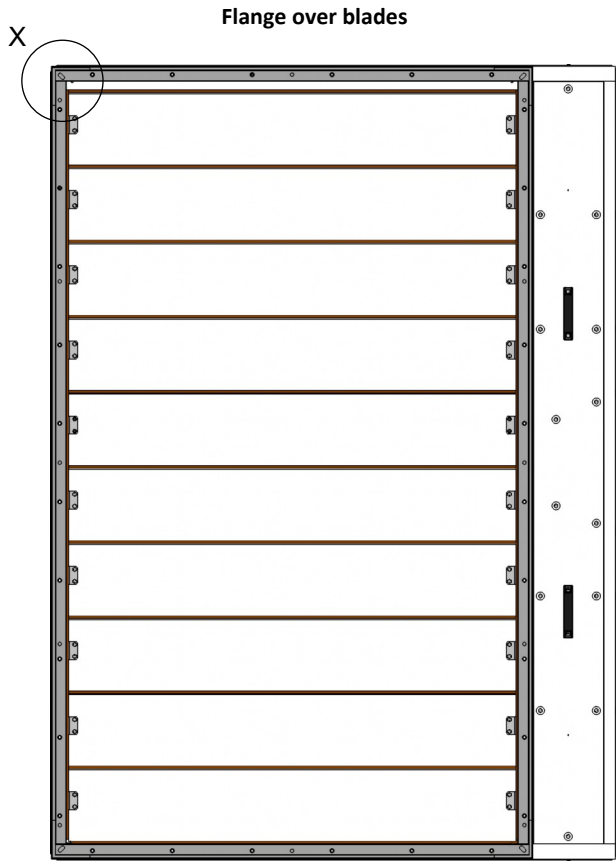

- 1 SEDM-L
- 2 Flange

7. Mounting the flange on the damper

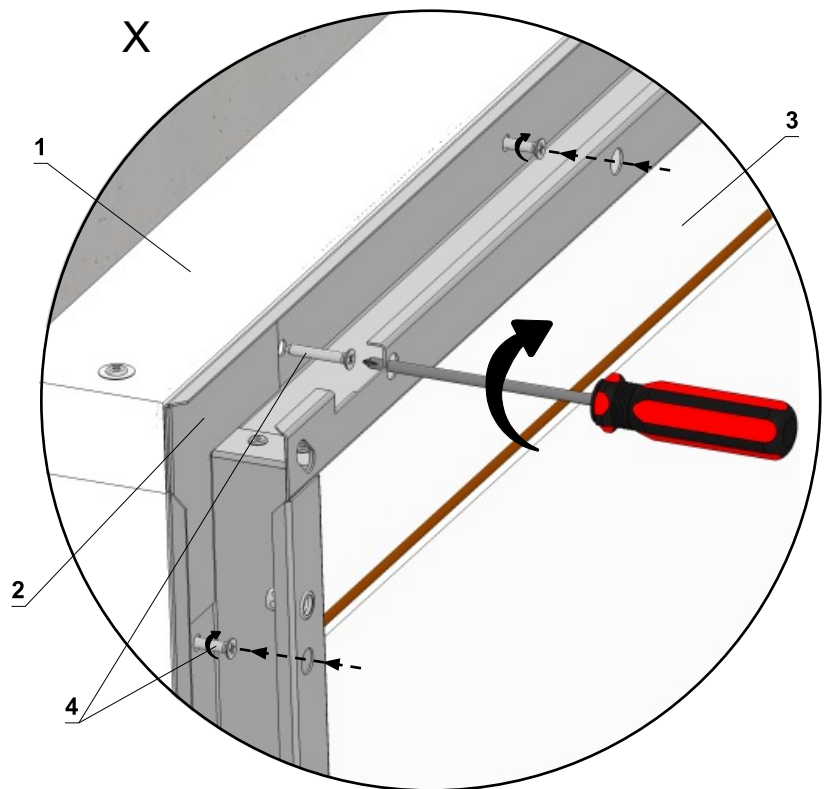

\* Fix in all holes, around the perimeter of the flange.

- 1 SEDM-L
- 2 Flange
- 3 Blades
- 4 Screw UNI 4x30 mm (included in the flange package)\*

8. Ways of placing the grille on the damper with a flange (2 types)

Grille over blades

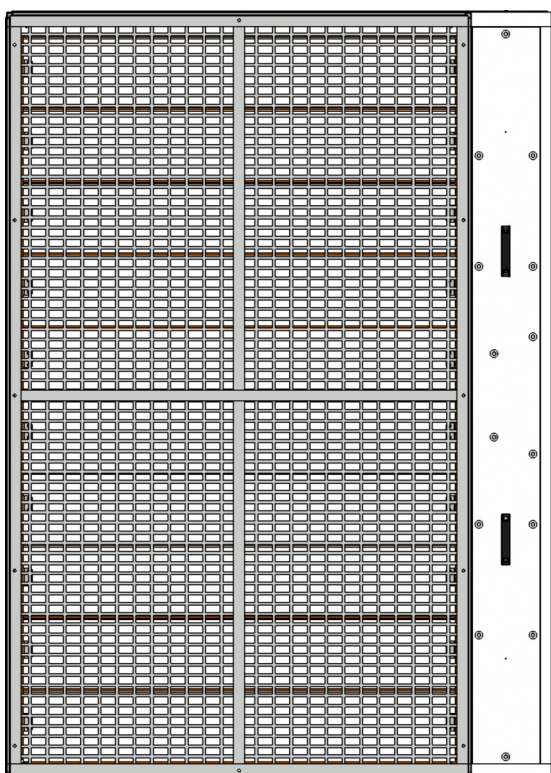

Grille over damper

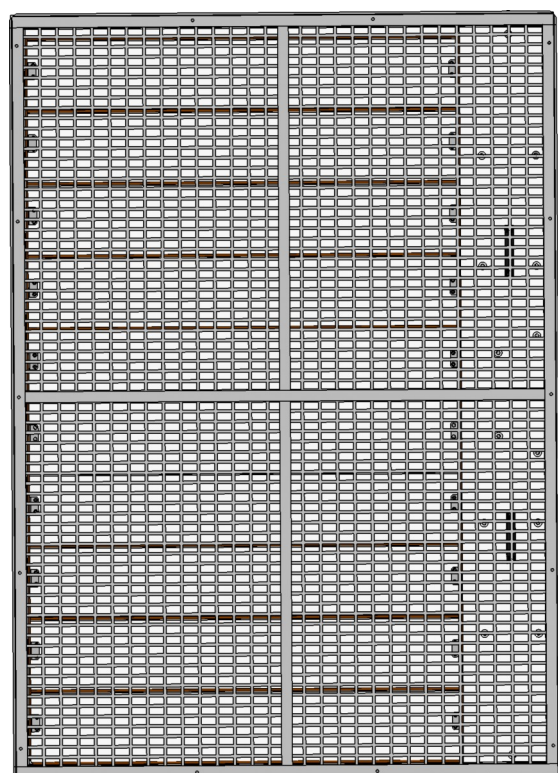

■ For a detail of the cover grille filling, → see page 11

9. Mounting the grille on the flange

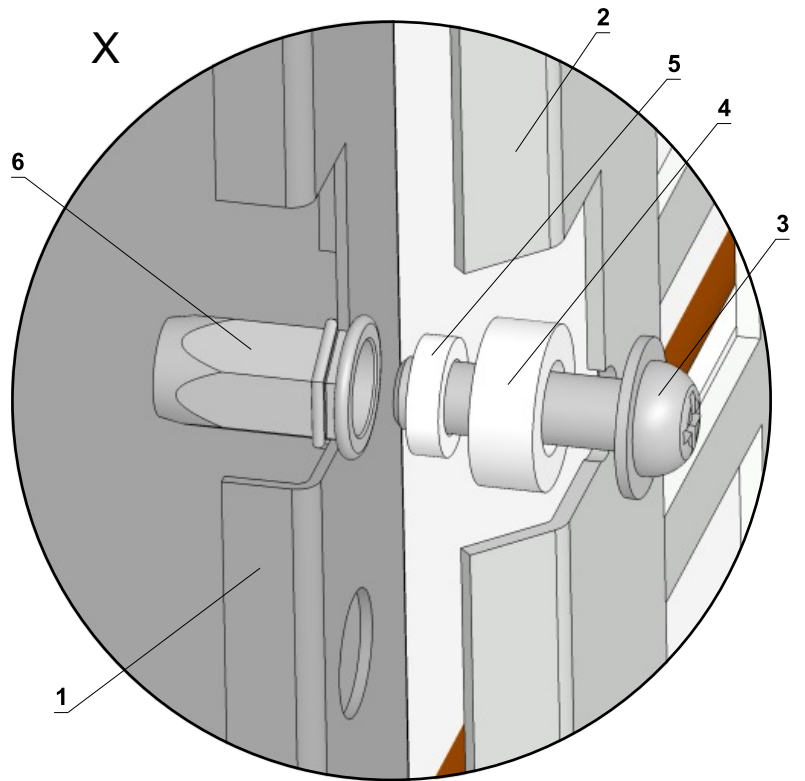
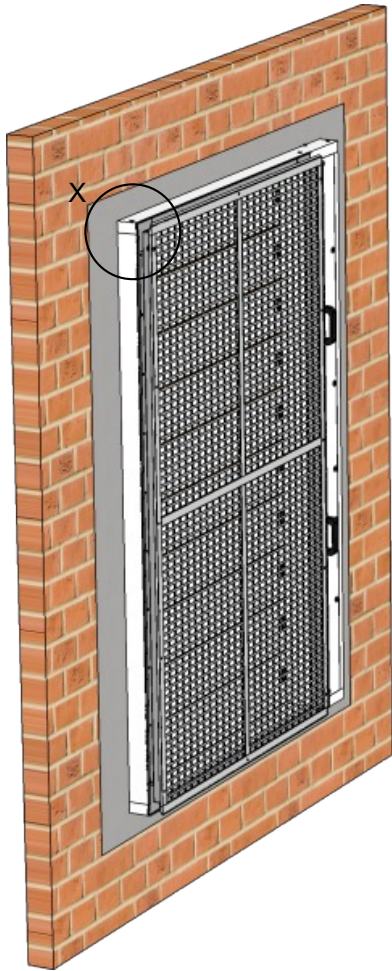

- 1 Flange
- 2 Grille
- 3 Bolt M6x20 type BN 4825 (included in the grille package)
- 4 Spacer ring (included in the grille package)
- 5 Retaining ring (included in the grille package)
- 6 Rivet nuts (mounted on the flange from the factory)

10. Mounting the handrail on the damper

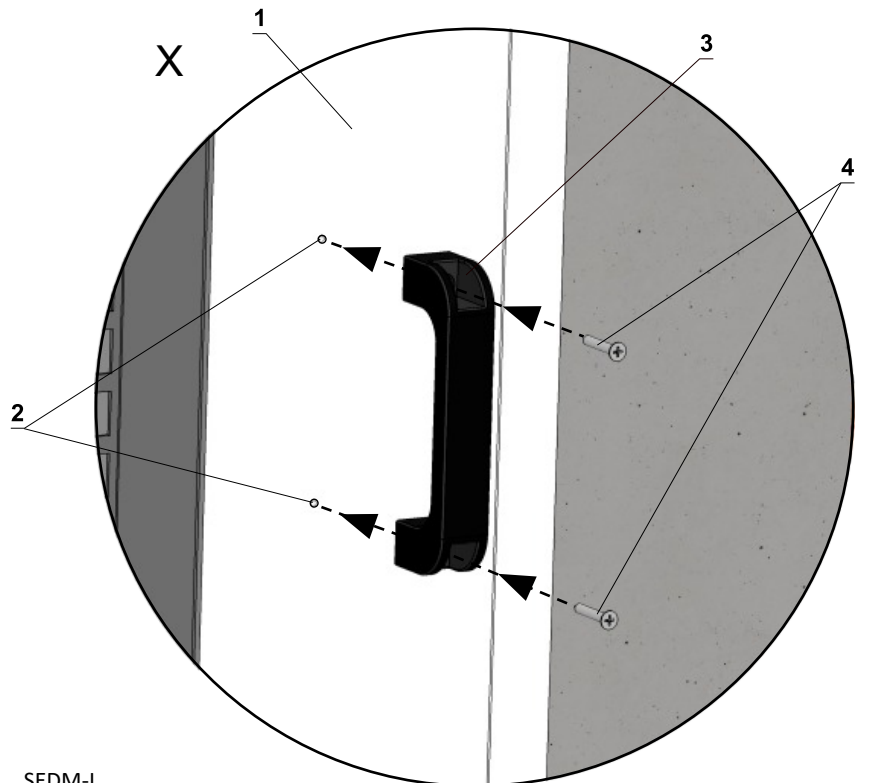
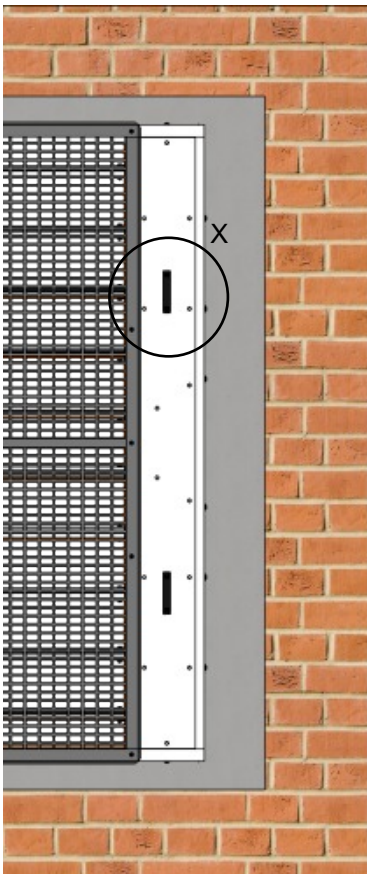

- 1 SEDM-L
- 2 Pre-drilled holes
- 3 Handrail (part of SEDM-L)
- 4 Screw UNI 5x50 mm (part of SEDM-L)

## Statement of installations

Fire separating construction, location of the damper	Installation type, installation system	Gap width [mm]	Classification	Page
Horizontal or vertical smoke extraction ducts tested according to EN 1366-8 or EN 1366-9 <ul style="list-style-type: none"> <li>into/onto the duct</li> </ul>	Damper installed into a duct or onto a duct with grille	N/A	EI120(V <sub>ed</sub> )S1000[H]C <sub>mod</sub> HOT400/30MAmulti	32-33
	Damper installed onto a duct without grille	N/A	EI90(V <sub>ed</sub> )S1000[H]C <sub>mod</sub> HOT400/30MAmulti	
Standard low- and high-density rigid wall construction according to EN 1363-1 <ul style="list-style-type: none"> <li>damper in the wall or shaft wall</li> <li>100 mm min. wall thickness</li> </ul>	Ablative Coated Batt	40-230	EI90(V <sub>edw</sub> )S1000[H]C <sub>mod</sub> HOT400/30MAmulti	27
		200	EI120(V <sub>edw</sub> )S1000[H]C <sub>mod</sub> HOT400/30MAmulti*	
	Mortar or gypsum**	50-150	EI90(V <sub>edw</sub> )S1000[H]C <sub>mod</sub> HOT400/30MAmulti	23-26
			EI120(V <sub>edw</sub> )S1000[H]C <sub>mod</sub> HOT400/30MAmulti*	
Standard flexible wall construction, min. EI90, according to EN 1363-1 <ul style="list-style-type: none"> <li>damper in the wall or shaft wall</li> <li>100 mm min. wall thickness</li> </ul>	Ablative Coated Batt	40-230	EI90(V <sub>edw</sub> )S1000[H]C <sub>mod</sub> HOT400/30MAmulti	29
		200	EI120(V <sub>edw</sub> )S1000[H]C <sub>mod</sub> HOT400/30MAmulti*	
	Mortar or gypsum	50-150	EI90(V <sub>edw</sub> )S1000[H]C <sub>mod</sub> HOT400/30MAmulti	28
			50	
Non-standard asymmetrical shaft wall construction, min. EI120, made of gypsum plasterboards (3 × 15 mm and 1 × 19 mm) with steel studs <ul style="list-style-type: none"> <li>damper in the wall or shaft wall</li> <li>107 mm min. wall thickness</li> </ul>	Mortar or gypsum	50-150	EI90(V <sub>edw</sub> )S1000[H]C <sub>mod</sub> HOT400/30MAmulti	30
			EI120(V <sub>edw</sub> )S1000[H]C <sub>mod</sub> HOT400/30MAmulti*	
Standard low- and high-density rigid floor construction according to EN 1366-2 <ul style="list-style-type: none"> <li>damper in the shaft floor</li> <li>150 mm min. wall thickness</li> </ul>	Mortar or gypsum	50-150	EI90(H <sub>od</sub> )S1000[H]C <sub>mod</sub> HOT400/30MAmulti EI120(H <sub>od</sub> )S1000[H]C <sub>mod</sub> HOT400/30MAmulti*	31

\* Where the damper is installed without a connected duct, the installation shall be terminated with a grille.

\*\* Including assembly of dampers – side by side → see pages 24 to 26

**In solid wall construction**

**In solid or shaft wall construction - mortar or gypsum**

- Standard low- and high-density rigid wall construction according to EN 1363-1
- Examples of anchors to the fire dividing construction → see pages 34 to 36
- Damper must be properly supported until the gypsum has fully hardened.

**EI90(v<sub>edw</sub>)S1000[H]C<sub>mod</sub>HOT400/30MAmulti**  
**EI120(v<sub>edw</sub>)S1000[H]C<sub>mod</sub>HOT400/30MAmulti<sup>1)</sup>**

1) Where the damper is installed without a connected duct, the installation shall be terminated with a grille.

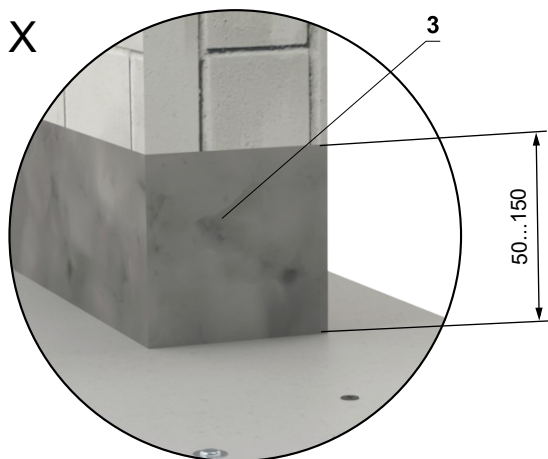

W = min. 50 mm  
 W = max. 150 mm

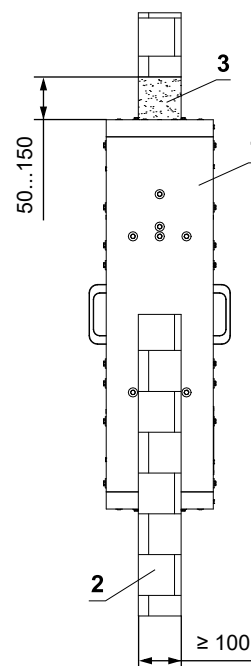
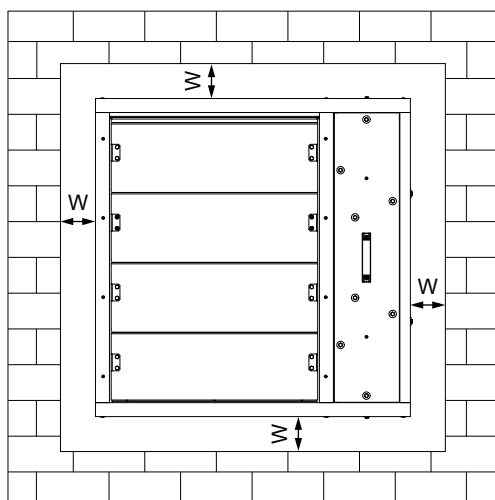
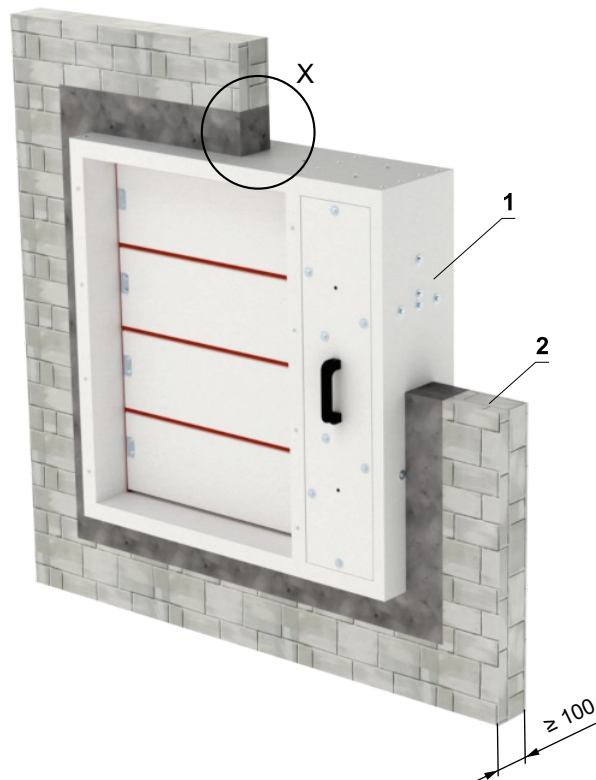

- 1 SEDM-L
- 2 Solid wall construction
- 3 Mortar or gypsum

**In solid or shaft wall construction - 2 dampers side by side - mortar or gypsum**

**EI90(v<sub>edw</sub>)S1000[H]C<sub>mod</sub>HOT400/30MAmulti  
EI120(v<sub>edw</sub>)S1000[H]C<sub>mod</sub>HOT400/30MAmulti<sup>1)</sup>**

- Standard low- and high-density rigid wall construction according to EN 1363-1
- Examples of anchors to the fire dividing construction → see pages 34 to 36
- Damper must be properly supported until the gypsum has fully hardened.
- Spacer straps and screw connections, are not included in the delivery!

1) Where the damper is installed without a connected duct, the installation shall be terminated with a grille.

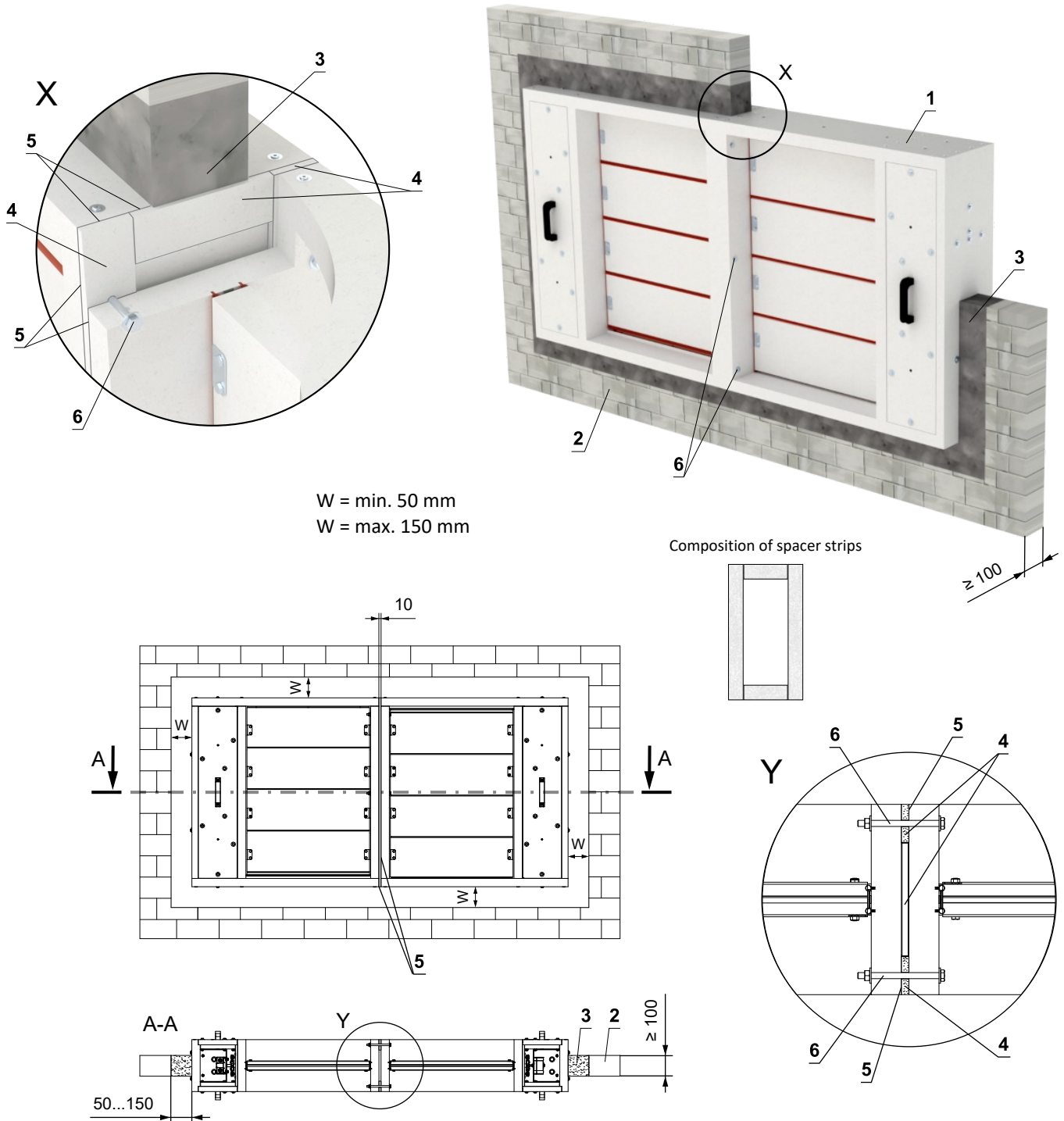

W = min. 50 mm  
W = max. 150 mm

**\* RESPECT JOINT POSITION !**  
Bolts and nuts shall not prevent free rotation on the blades.

- 1 SEDM-L
- 2 Solid wall construction
- 3 Mortar or gypsum
- 4 Spacing strip (e.g. Promactect-H, th. 10 mm, width 50 mm) - glue with HILTI CFS-S ACR (position 5) to the damper body
- 5 Fire-resistant mastic - (HILTI CFS-S ACR...)
- 6 M8 bolt assembly (bolt M8x105 mm, 2 pcs large washer M8, nut M8)\*

**In solid or shaft wall construction - 2 on top of each other - mortar or gypsum**

**EI90(v<sub>edw</sub>)S1000[H]C<sub>mod</sub>HOT400/30MAmulti**  
**EI120(v<sub>edw</sub>)S1000[H]C<sub>mod</sub>HOT400/30MAmulti<sup>1)</sup>**

- Standard low- and high-density rigid wall construction according to EN 1363-1
- Examples of anchors to the fire dividing construction → see pages 34 to 36
- Damper must be properly supported until the gypsum has fully hardened.
- Spacer straps and screw connections, are not included in the delivery!

1) Where the damper is installed without a connected duct, the installation shall be terminated with a grille.

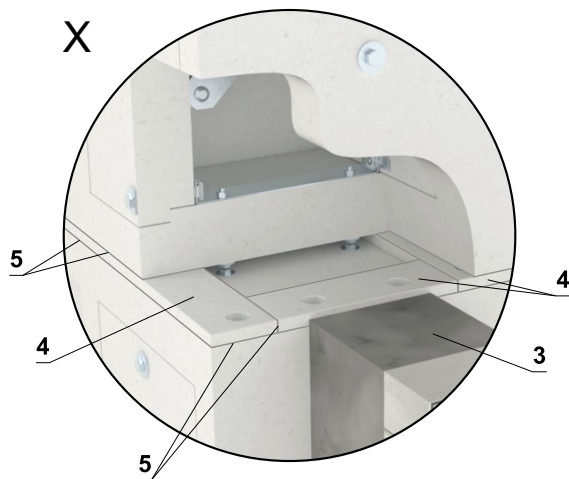

- If the spacer strip rests on the screw head, it is necessary to create a recess in this place (alternatively drill a hole).

Composition of spacer strips

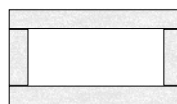

W = min. 50 mm  
 W = max. 150 mm

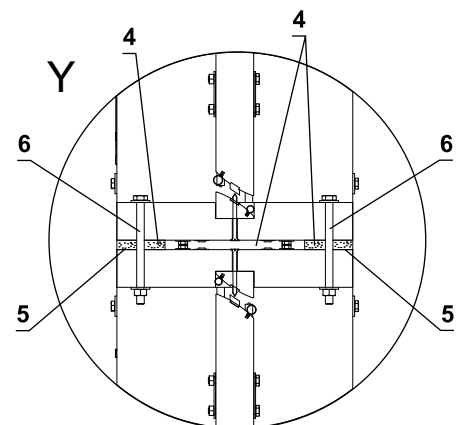
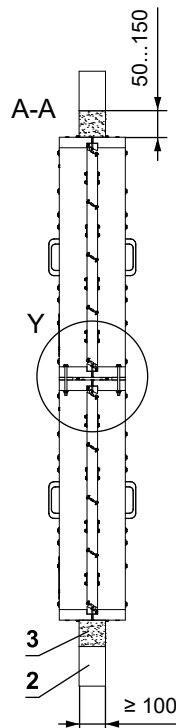
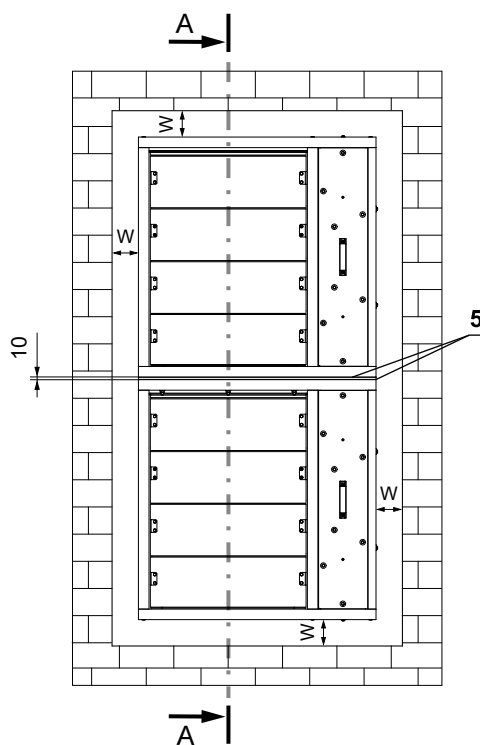
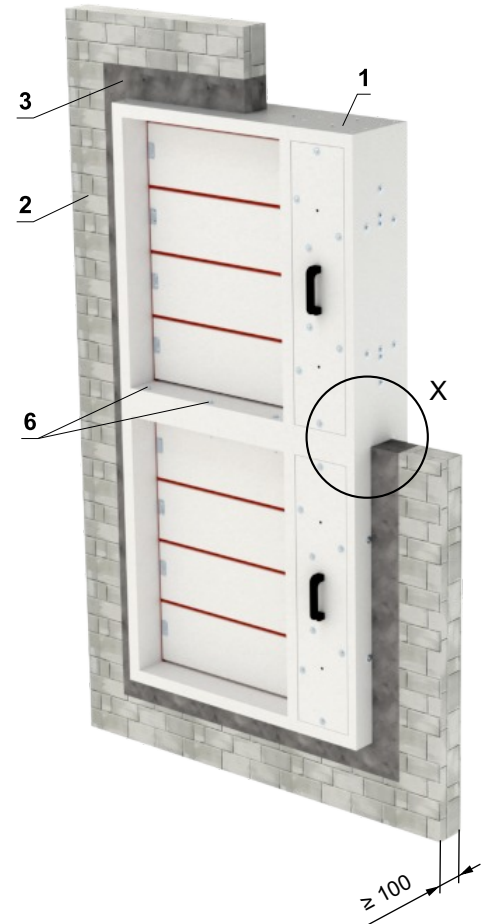

- 1 SEDM-L
- 2 Solid wall construction
- 3 Mortar or gypsum
- 4 Spacing strip (e.g. Promatect-H, th. 10 mm, width 50 mm) - glue with HILTI CFS-S ACR (position 5) to the damper body
- 5 Fire-resistant mastic - (HILTI CFS-S ACR...)
- 6 M8 bolt assembly (bolt M8x105 mm, 2 pcs large washer M8, nut M8)

In solid or shaft wall construction - 4 dampers - mortar or gypsum

EI90(v<sub>edw</sub>)S1000[H]C<sub>mod</sub>HOT400/30MAmulti  
 EI120(v<sub>edw</sub>)S1000[H]C<sub>mod</sub>HOT400/30MAmulti<sup>1)</sup>

- Standard low- and high-density rigid wall construction according to EN 1363-1
- Examples of anchors to the fire dividing construction → see pages 34 to 36
- Damper must be properly supported until the gypsum has fully hardened.
- Spacer straps and screw connections, are not included in the delivery!

1) Where the damper is installed without a connected duct, the installation shall be terminated with a grille.

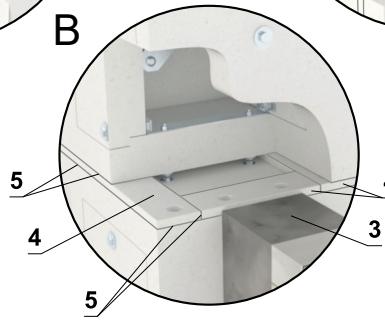
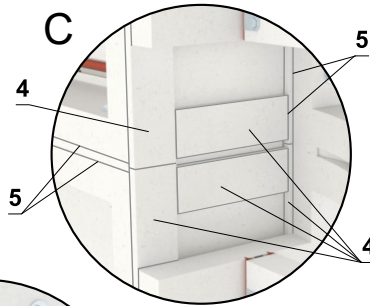
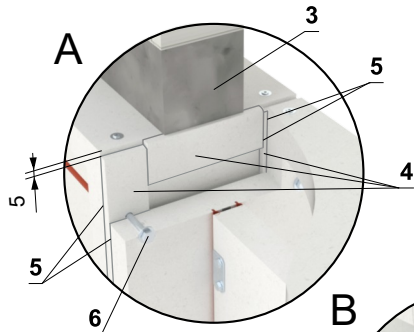

- If the spacer strip rests on the screw head, it is necessary to create a recess in this place (alternatively drill a hole).

W = min. 50 mm  
 W = max. 150 mm

Composition of spacer strips (B)

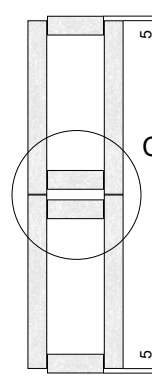

Composition of spacer strips (A)

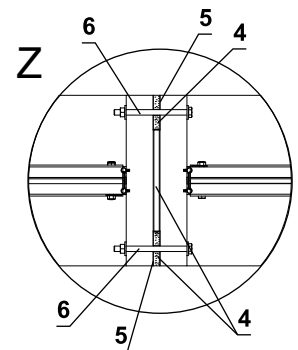
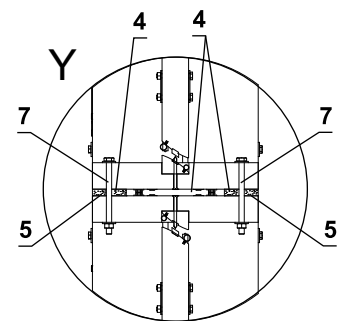
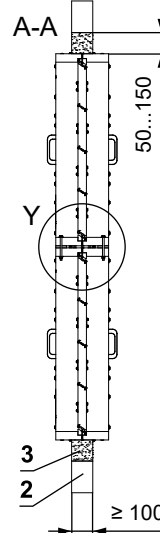
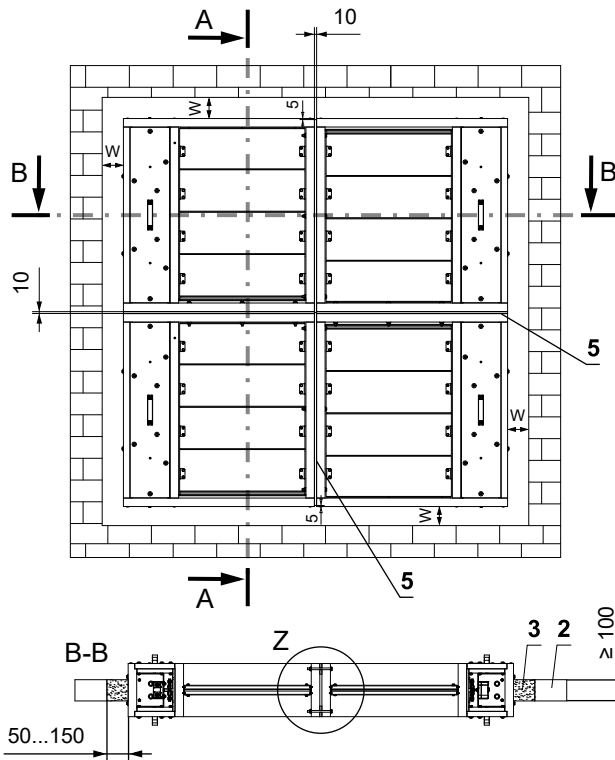
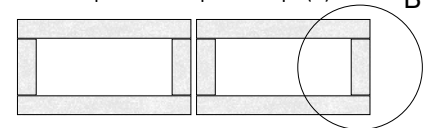

- 1 SEDM-L
- 2 Solid wall construction
- 3 Mortar or gypsum
- 4 Spacing strip (e.g. Promactec-H, th. 10 mm, width 50 mm) - glue with HILTI CFS-S ACR (position 5) to the damper body
- 5 Fire-resistant mastic - (HILTI CFS-S ACR...)
- 6 M8 bolt assembly (bolt M8x105 mm, 2 pcs large washer M8, nut M8)\*
- 7 M8 bolt assembly (bolt M8x105 mm, 2 pcs large washer M8, nut M8), span 200-300 mm

\* **RESPECT JOINT POSITION !**  
 Bolts and nuts shall not prevent free rotation on the blades.

**In solid or shaft wall construction - Ablative Coated Batt**

- Standard low- and high-density rigid wall construction according to EN 1363-1
- Examples of anchors to the fire dividing construction → see pages 34 to 36

**EI90(v<sub>edw</sub>)S1000[H]C<sub>mod</sub>HOT400/30MAmulti**  
**\*EI120(v<sub>edw</sub>)S1000[H]C<sub>mod</sub>HOT400/30MAmulti<sup>1)</sup>**

1) Where the damper is installed without a connected duct, the installation shall be terminated with a grille.

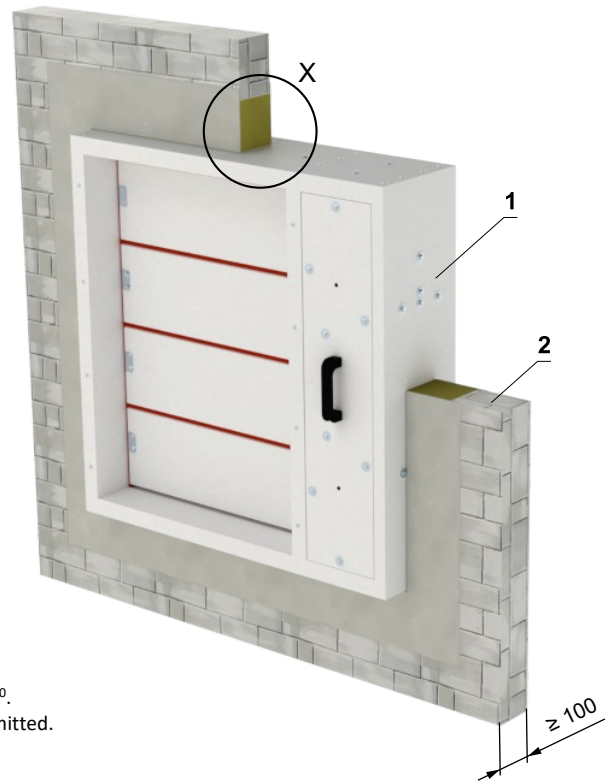
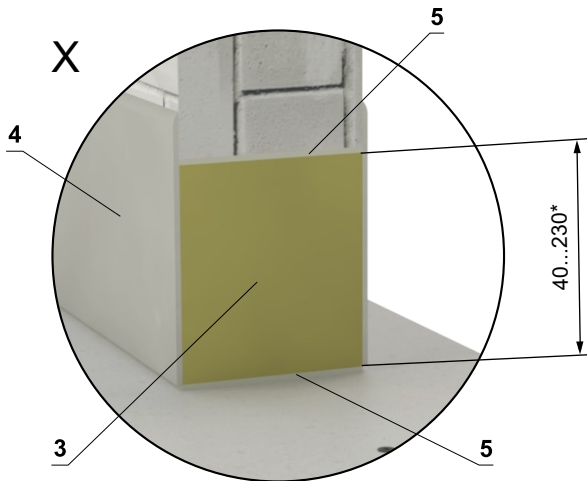

\* In the case of fire resistance EI 120, the installation gap is limited to 200 mm <sup>+0/-10</sup>.  
 For fire resistance EI 90 or lower, an installation gap range of 40–230 mm is permitted.

W = min. 40 mm\*  
 W = max. 230 mm\*

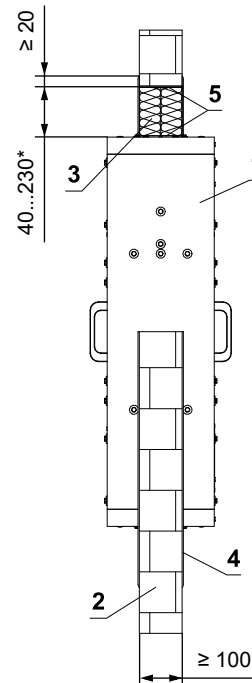
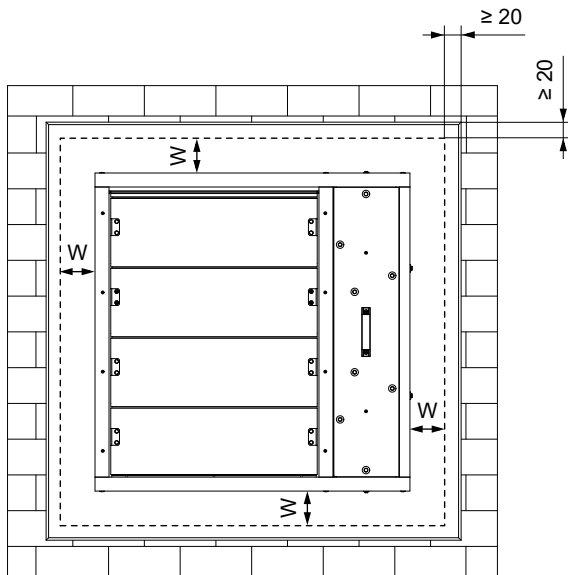

- 1 SEDM-L
- 2 Solid wall construction  
Ablative Coated Batt System HILTI\*\*
- 3 Mineral wool board - min. density 140 kg/m<sup>3</sup> (HILTI CFS-CT B 1S 140/50...)
- 4 Fire stop coating - th. 1 mm (HILTI CFS-CT...) - coating is overcoated on the support construction and on the damper casing/duct.
- 5 Fire-resistant mastic - (HILTI CFS-S ACR...) fill the gap from both sides of the fire separation construction and around the perimeter of penetration and damper casing.

\*\* HILTI system can be replaced by a similar system with the same or higher thickness, density, fire reaction class, tested according to EN 1366-3.

**In gypsum wall construction**

**In gypsum wall or shaft wall construction min. EI 90 - mortar or gypsum**

- Standard flexible wall construction min. EI 90 according to EN 1363-1.
- Examples of anchors to the fire dividing construction → see pages 34 to 36
- Damper must be properly supported until the gypsum has fully hardened.
- The installation opening is lined with a UW/CW profile.

**EI90(v<sub>edw</sub>)S1000[H]C<sub>mod</sub>HOT400/30MAmulti**  
**\*EI120(v<sub>edw</sub>)S1000[H]C<sub>mod</sub>HOT400/30MAmulti<sup>1]</sup>**

1] Where the damper is installed without a connected duct, the installation shall be terminated with a grille.

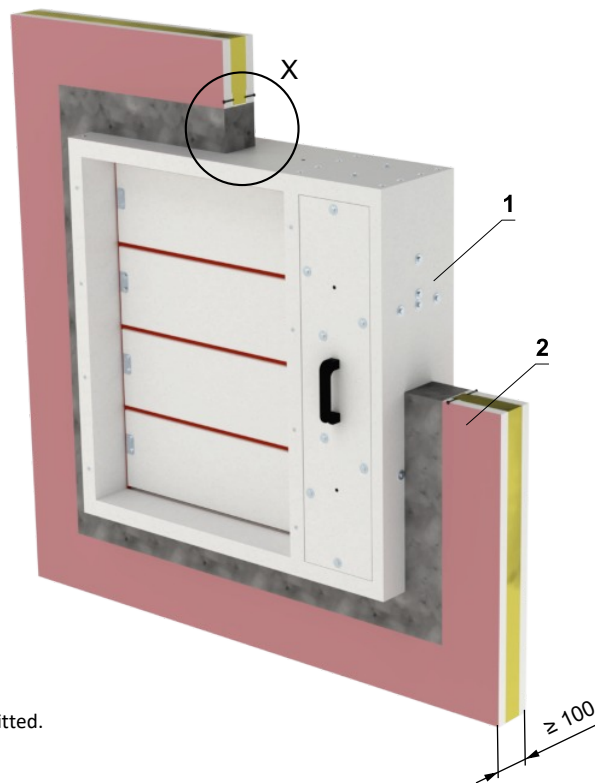
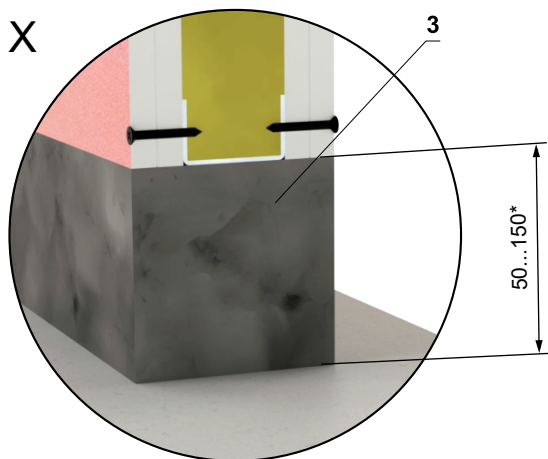

\* In the case of fire resistance EI 120, the installation gap is limited to 50 mm <sup>+10/-0</sup>.  
 For fire resistance EI 90 or lower, an installation gap range of 50–150 mm is permitted.

W = min. 50 mm\*  
 W = max. 150 mm\*

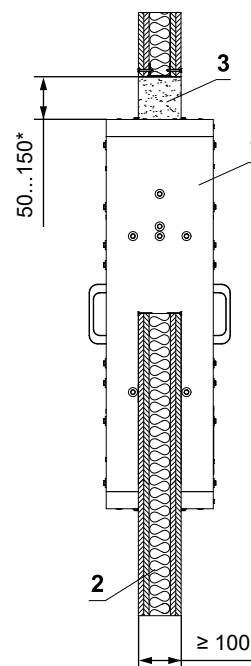
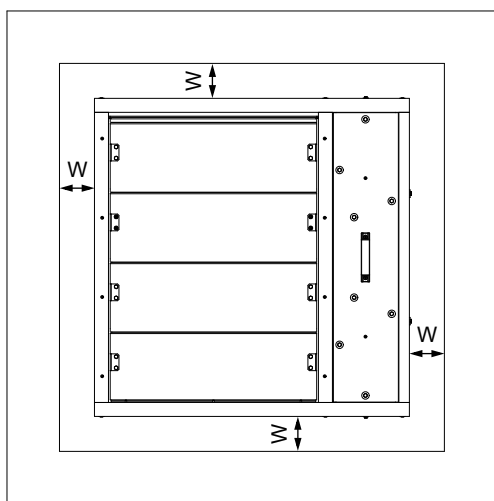

- 1 SEDM-L
- 2 Gypsum wall construction
- 3 Mortar or gypsum

**In gypsum wall or shaft wall construction min. EI 90 - Ablative Coated Batt**

- Standard flexible wall construction min. EI 90 according to EN 1363-1.
- Examples of anchors to the fire dividing construction → see pages 34 to 36
- The installation opening is lined with a UW/CW profile.

**EI90(v<sub>edw</sub>)S1000[H]C<sub>mod</sub>HOT400/30MAmulti**  
**\*EI120(v<sub>edw</sub>)S1000[H]C<sub>mod</sub>HOT400/30MAmulti<sup>1]</sup>**

1] Where the damper is installed without a connected duct, the installation shall be terminated with a grille.

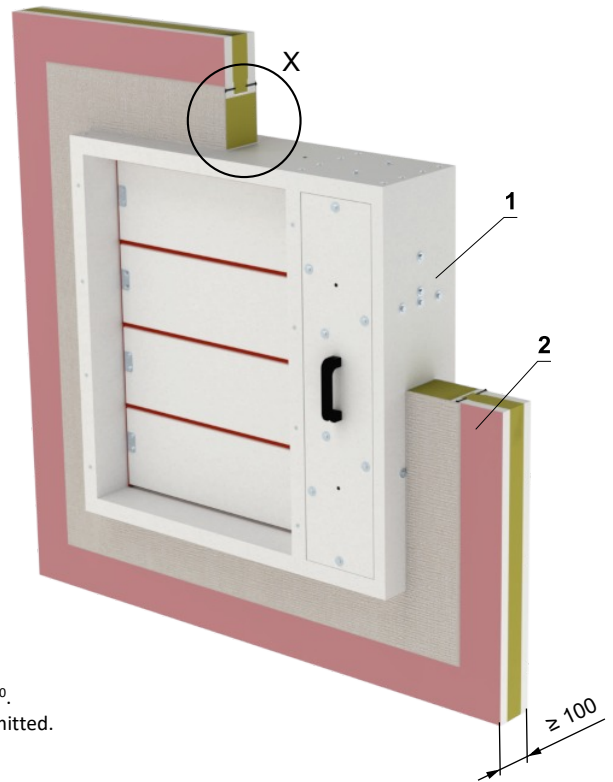
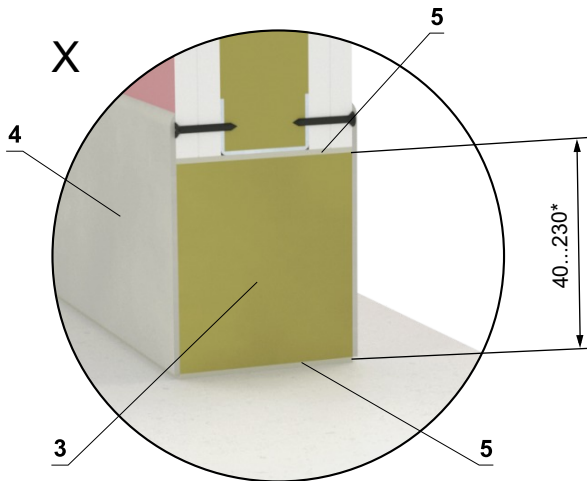

\* In the case of fire resistance EI 120, the installation gap is limited to 200 mm <sup>+0/-10</sup>.  
 For fire resistance EI 90 or lower, an installation gap range of 40–230 mm is permitted.

W = min. 40 mm\*  
 W = max. 230 mm\*

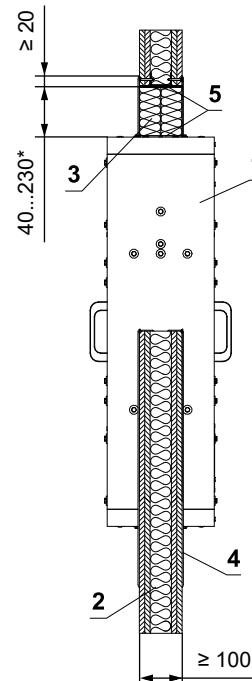
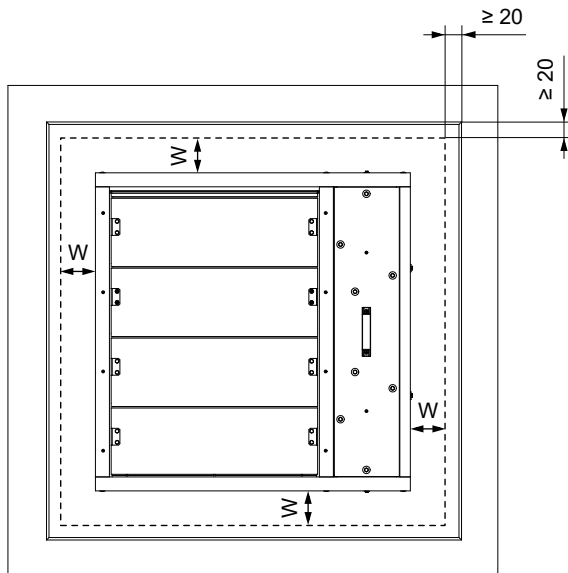

- 1 SEDM-L
- 2 Gypsum wall construction  
Ablative Coated Batt System HILTI\*\*
- 3 Mineral wool board - min. density 140 kg/m<sup>3</sup> (HILTI CFS-CT B 1S 140/50...)
- 4 Fire stop coating - th. 1 mm (HILTI CFS-CT...) - coating is overcoated on the support construction and on the damper casing/duct.
- 5 Fire-resistant mastic - (HILTI CFS-S ACR...) fill the gap from both sides of the fire separation construction and around the perimeter of penetration and damper casing.

\*\* HILTI system can be replaced by a similar system with the same or higher thickness, density, fire reaction class, tested according to EN 1366-3.

**In shaft wall construction**

**In shaft wall construction min. EI 120 - mortar or gypsum**

- Non-standard asymm. shaft wall construction, min. EI 120
- Examples of anchors to the fire dividing construction → see pages 34 to 36
- It is possible to use e.g. wall type A306030... from [www.british-gypsum.com](http://www.british-gypsum.com)
- It is possible to use walls that have the same or greater thickness and density of boards than the walls listed below (more layers of boards can also be used)
- Follow the instructions of the shaft wall manufacturer.
- Damper must be properly supported until the gypsum has fully hardened.

**EI120(v<sub>edw</sub>)S1000[H]C<sub>mod</sub>HOT400/30MAmulti<sup>1]</sup>**

1] Where the damper is installed without a connected duct, the installation shall be terminated with a grille.

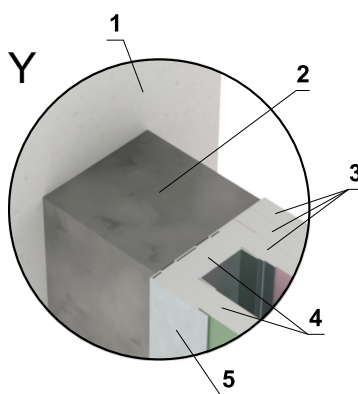
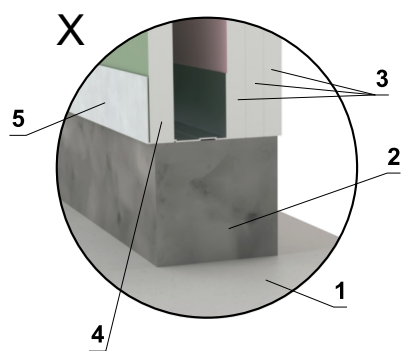

W = min. 50 mm  
W = max. 150 mm

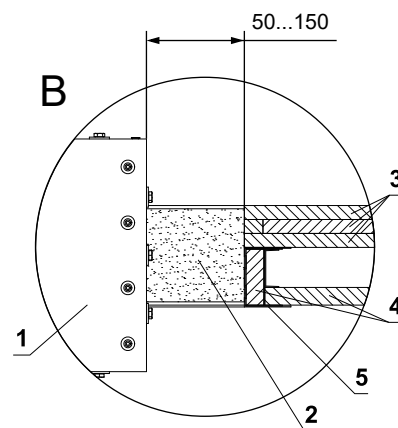
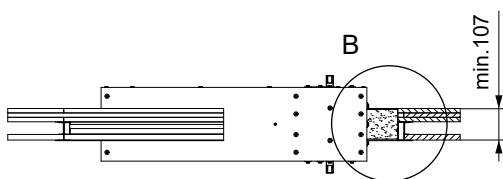
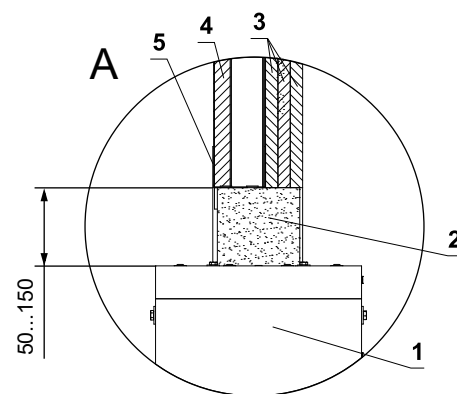
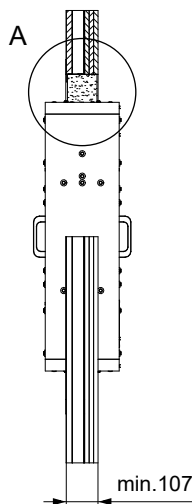
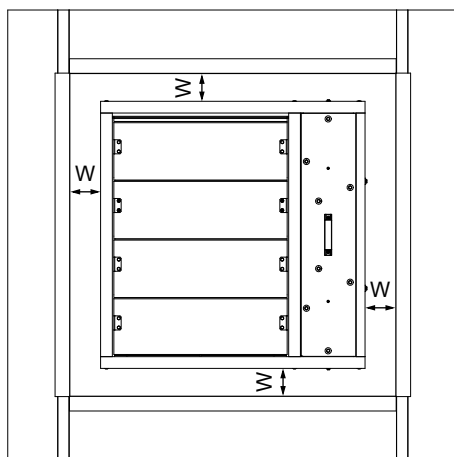
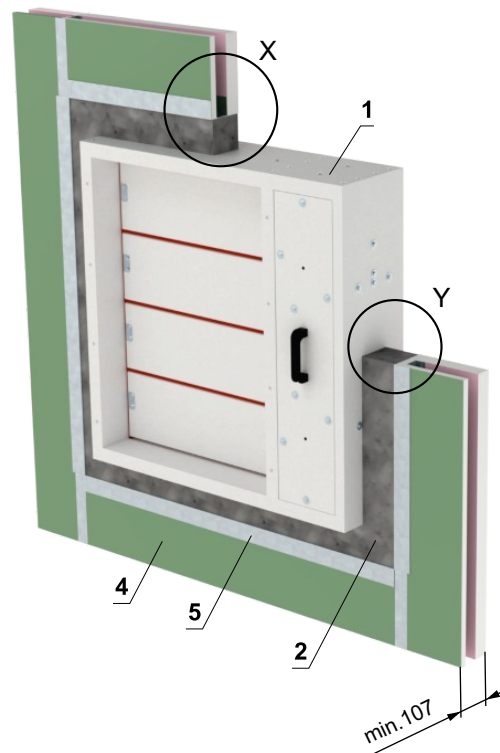

- 1 SEDM-L
- 2 Mortar or gypsum
- 3 Plasterboard EN 520 - Type F min. 3x15 mm
- 4 Plasterboard EN 520 - Type F min. 1x19 mm
- 5 Plasteboard profile

### In solid ceiling construction

#### In solid ceiling construction - mortar or gypsum

- Standard low- and high-density rigid floor construction according to EN 1366-2
- Examples of anchors to the fire dividing construction → see pages 34 to 36
- Damper must be properly supported until the gypsum has fully hardened.
- The damper can be installed from both sides of the construction, i.e. From the top or the bottom side of the ceiling

EI90(h<sub>od</sub>)S1000[H]C<sub>mod</sub>HOT400/30MAmulti  
EI120(h<sub>od</sub>)S1000[H]C<sub>mod</sub>HOT400/30MAmulti<sup>1)</sup>

1) Where the damper is installed without a connected duct, the installation shall be terminated with a grille.

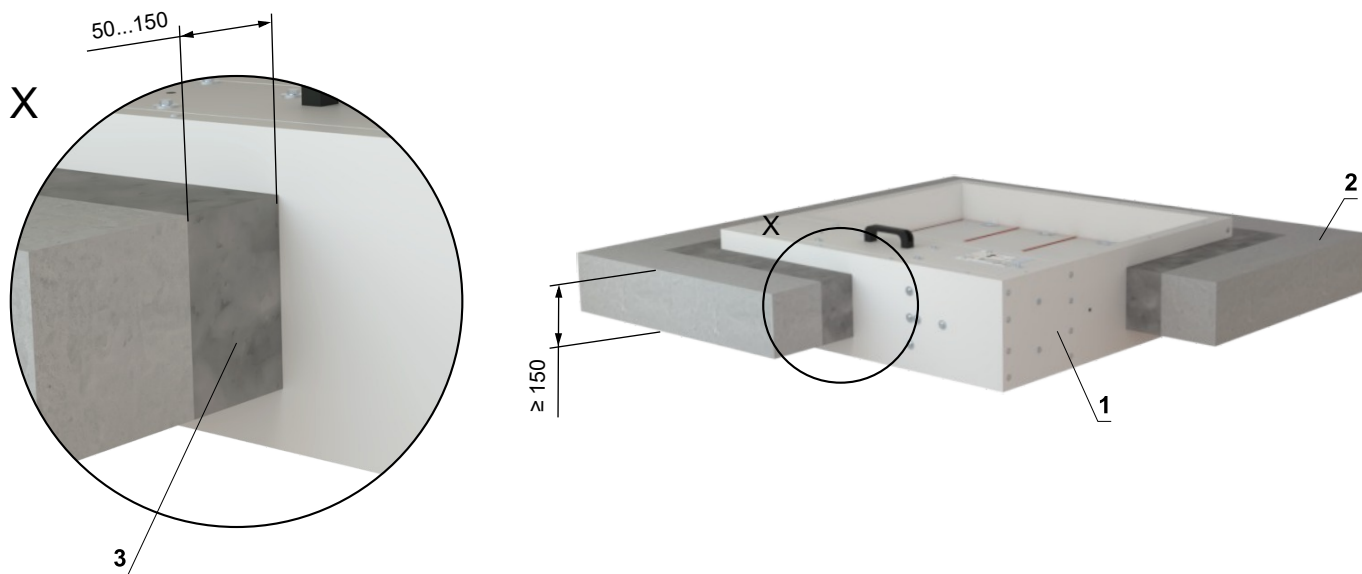

W = min. 50 mm  
W = max. 150 mm

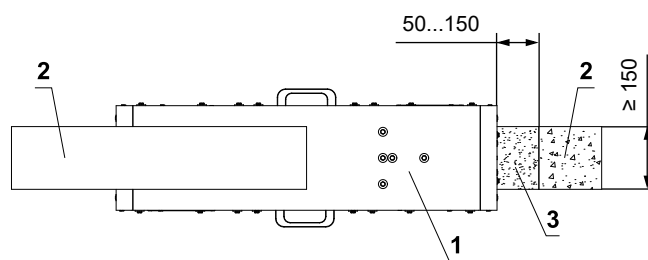
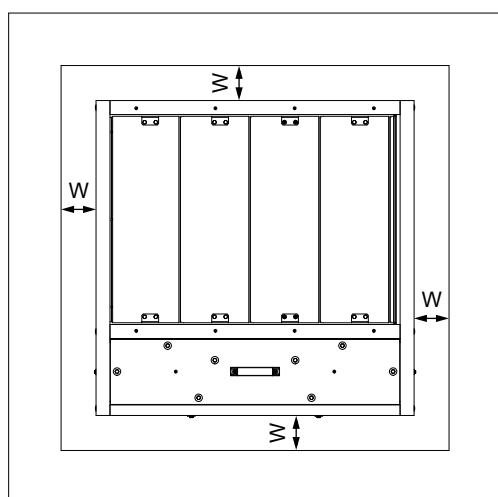

- 1 SEDM-L
- 2 Solid ceiling construction
- 3 Mortar or gypsum

Installation damper into/onto smoke extraction ducts

EI90(v<sub>ed</sub>)S1000[H]C<sub>mod</sub>HOT400/30MAmulti<sup>1)</sup>  
 EI120(v<sub>ed</sub>)S1000[H]C<sub>mod</sub>HOT400/30MAmulti<sup>2)</sup>

1) Damper installed onto a duct without grille  
 2) Damper installed into a duct or onto a duct with grille

- The dampers may be installed onto or into smoke extraction ducts listed below:
  - **Flameshield Fireduct (manufacturer Kent Ductwork Ltd.)**  
 The duct is made of 1.2 mm thick galvanized steel sheet and insulated with 1 layer of 90 mm thick stone wool Rockwool FirePro DuctRock Slab (manufacturer ROCKWOOL Ltd.). The stone wool is finished with a black aluminium foil on the outer side.
  - **FPL08 (manufacturer Fire Protection Ltd)**  
 The duct is made of galvanized steel sheet. The thickness of the duct depends of its dimensions. The surface of the duct is fire sprayed with Flamebar BW11 (manufacturer Firespray International Ltd). The duct is insulated with two layers of stone wool. The first layer is made of 50 mm thick ROCKWOOL FPL 110 SLAB and the second layer with aluminium foil is made of 50 mm thick ROCKWOOL FPL 110 FOIL FACED SLAB (manufacturer ROCKWOOL Ltd.).
- The dampers may be installed onto or into other smoke extraction ducts than that specified above with the following limitations:
  - The duct shall be tested according to EN 1366-9 or EN 1366-8 depending on the intended use,
  - The duct shall be made of material of the same or greater density and of the same or greater thickness as the ducts listed below,
  - Changing surface protection materials is not permitted,
  - Changing the paint surface finish is not permitted.
- The damper must be independetly provided with a duct support within 100 mm of the centre of the damper blade axis.
- Support, drop rods, anchors etc. must be used in accordance with a duct manufacturer instructions.
- The connected duct shall be suspended in such a way that the transfer of all loads from the duct to the damper is completely excluded.
- The damper may be installed in vertical position with the horizontal position of the blades axis.

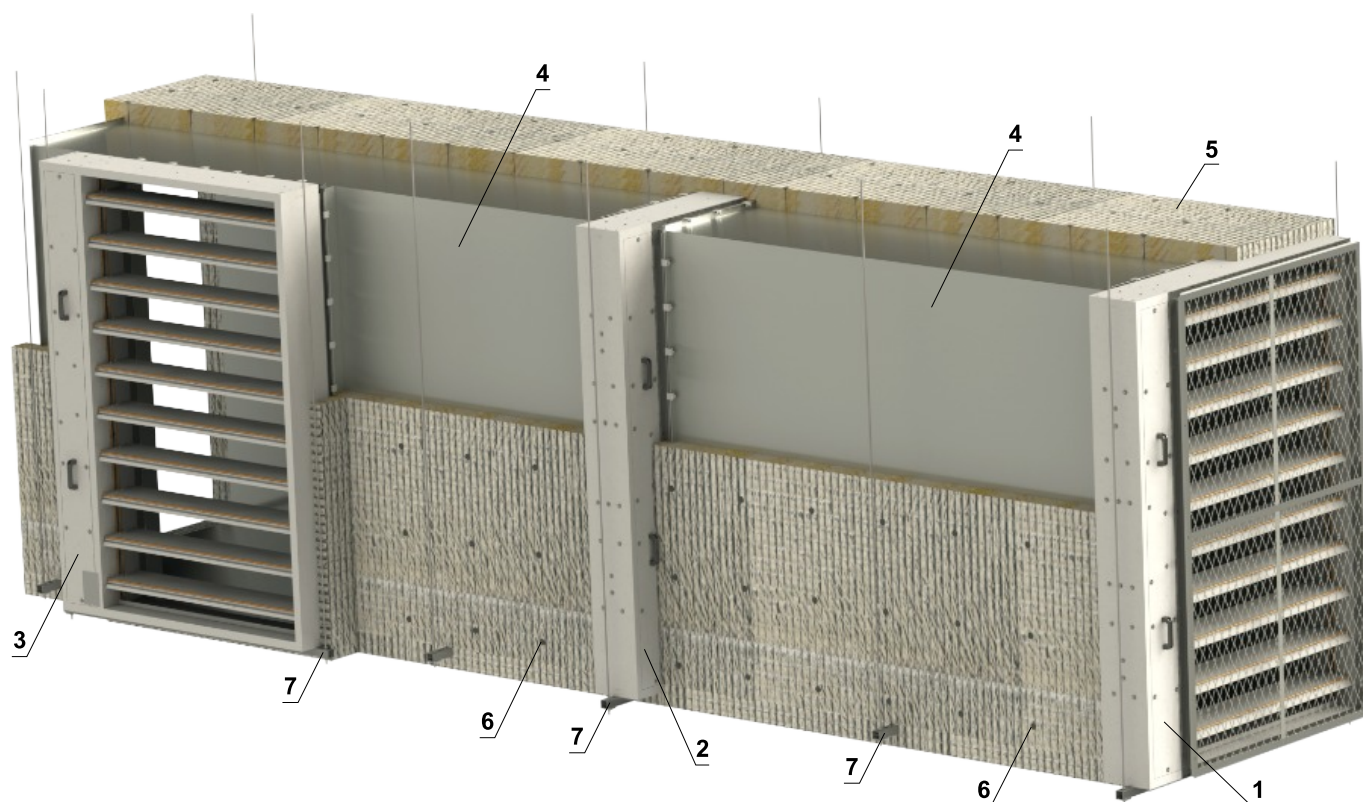

- 1 SEDM-L 2x flange, 1x grille
- 2 SEDM-L 2x flange
- 3 SEDM-L 1x flange\*
- 4 Smoke extraction duct (according to duct manufacturer)
- 5 Surface protection material (according to duct manufacturer)
- 6 Steel instulation pin (according to duct manufacturer)
- 7 Smoke extraction damper and duct supports (according to duct manufacturer)

\* If the damper is installed as the final element in the duct system (i.e. with no ducting behind it), it must be fitted with a grille. Otherwise, the fire resistance will be reduced to EI 90 S.

(continued on next page)

**continuation of installation damper into/onto smoke extraction ducts**

- The damper is connected to the smoke extraction duct by the damper flange as follow:
  - M10 bolts, washers and nuts are used at the corners of the flange
  - C-clamps with M8 bolts with a maximum spacing of 200 mm are used around the circumference
  - Ceramic selfadhesive sealing tape is inserted between flanges
  - The gap between the flanges is filled with intumescent acrylic sealant\*
- The duct insulation is stretched at least 125 mm on three sides of the damper body and attached to the damper with Screws with diameter 5 mm and a washer M5 (DIN 125A) with a maximum spacing 200 mm.

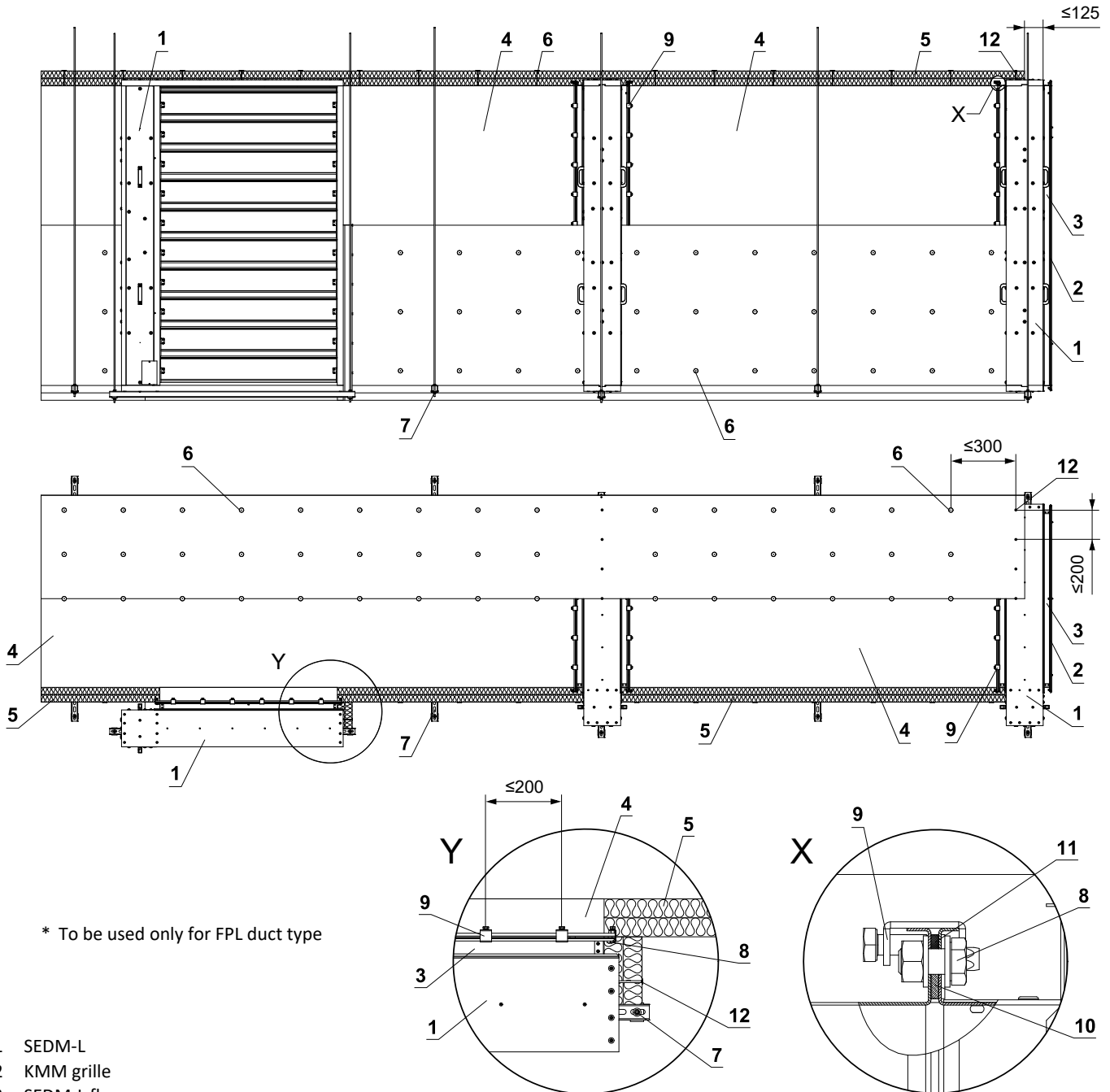

\* To be used only for FPL duct type

- 1 SEDM-L
- 2 KMM grille
- 3 SEDM-L flange
- 4 Smoke extraction duct
- 5 Surface protection material (type according to duct manufacturer instructions)
- 6 Steel instulation pin (type according to duct manufacturer instructions)
- 7 Suspension system (type according to duct manufacturer instructions)
- 8 Flange connection at corners - M10 bolt, washers and nut
- 9 M8 C-clamps - maximum spacing of C-clamps 200 mm (type according to duct manufacturer instructions)
- 10 Ceramic selfadhesive sealing tape - arround the duct circumference (type according to duct manufacturer instructions)
- 11 Intumescent acrylic Sealant - arround the duct circumference (type according to duct manufacturer instructions)\*
- 12 Insulation connection to the damper body - washer M5 (DIN 125A), screw 5xL mm (screw lenght = insullation thickness + 20 mm)

# V. SUSPENSION SYSTEMS

## Fixing SEDM-L to the solid wall construction - Ablative Coated Batt

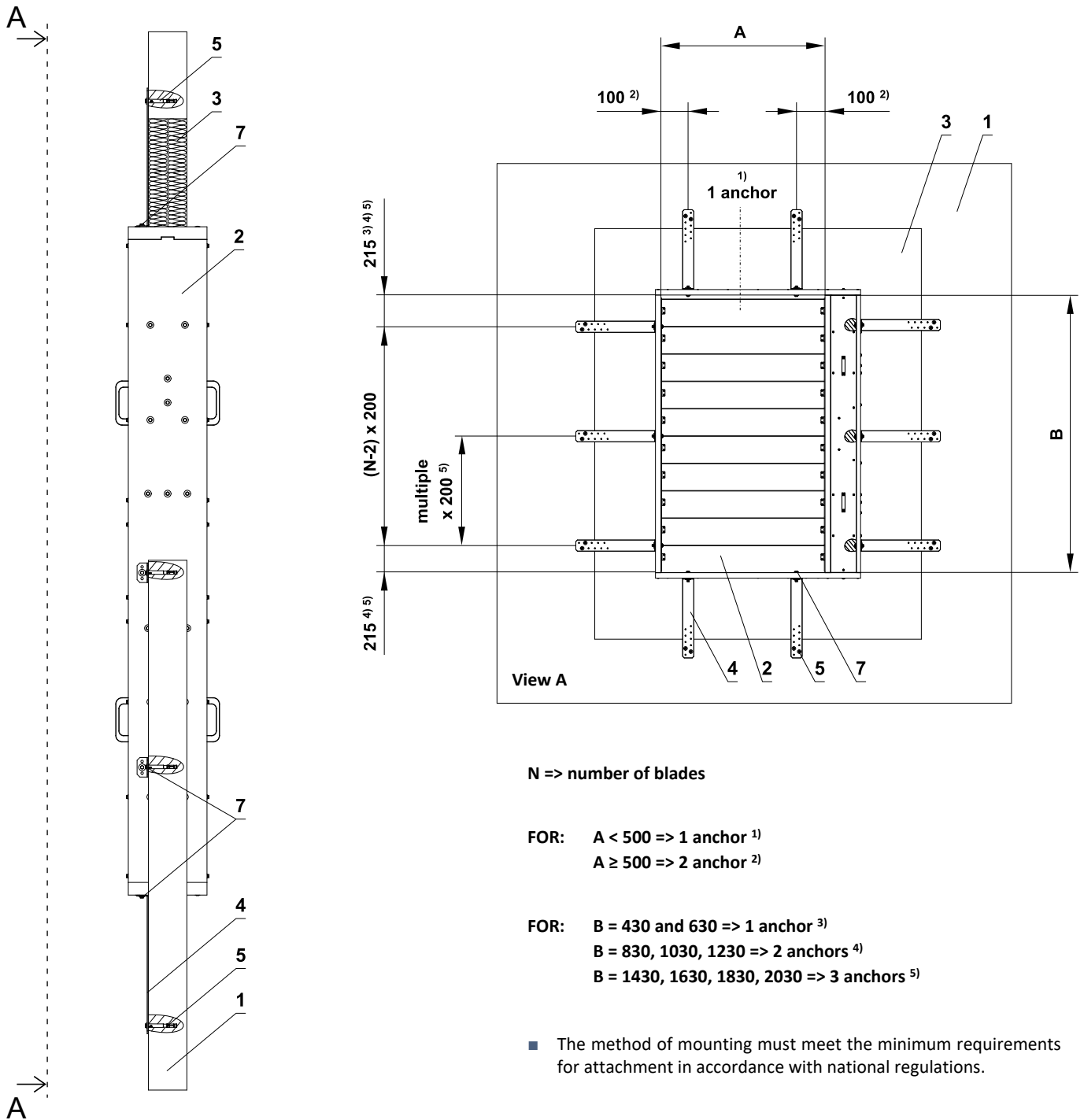

**\* RESPECT JOINT POSITION !**  
 Bolts and nuts shall not prevent free rotation on the blades.

- 1 Solid wall construction
- 2 SEDM-L
- 3 Ablative Coated Batt
- 4 Installation holder for connecting damper to the wall (optional accessories MANDIK, a.s. or sheet metal min. thickness 2 mm and min. width 60 mm). Full drawing of bracket, → see page 36
- 5 Anchor to concrete min. M6
- 6 Installation hols
- 7 M8 bolt assembly (bolt M8x55 mm, 2 pcs large washer M8, nut M8) \*

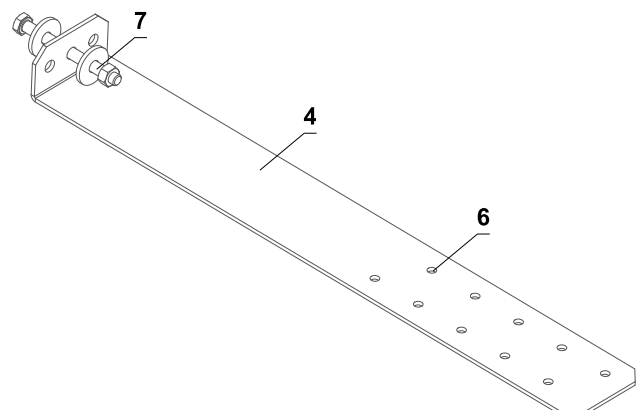

Fixing SEDM-L to the gypsum wall construction - Ablative Coated Batt

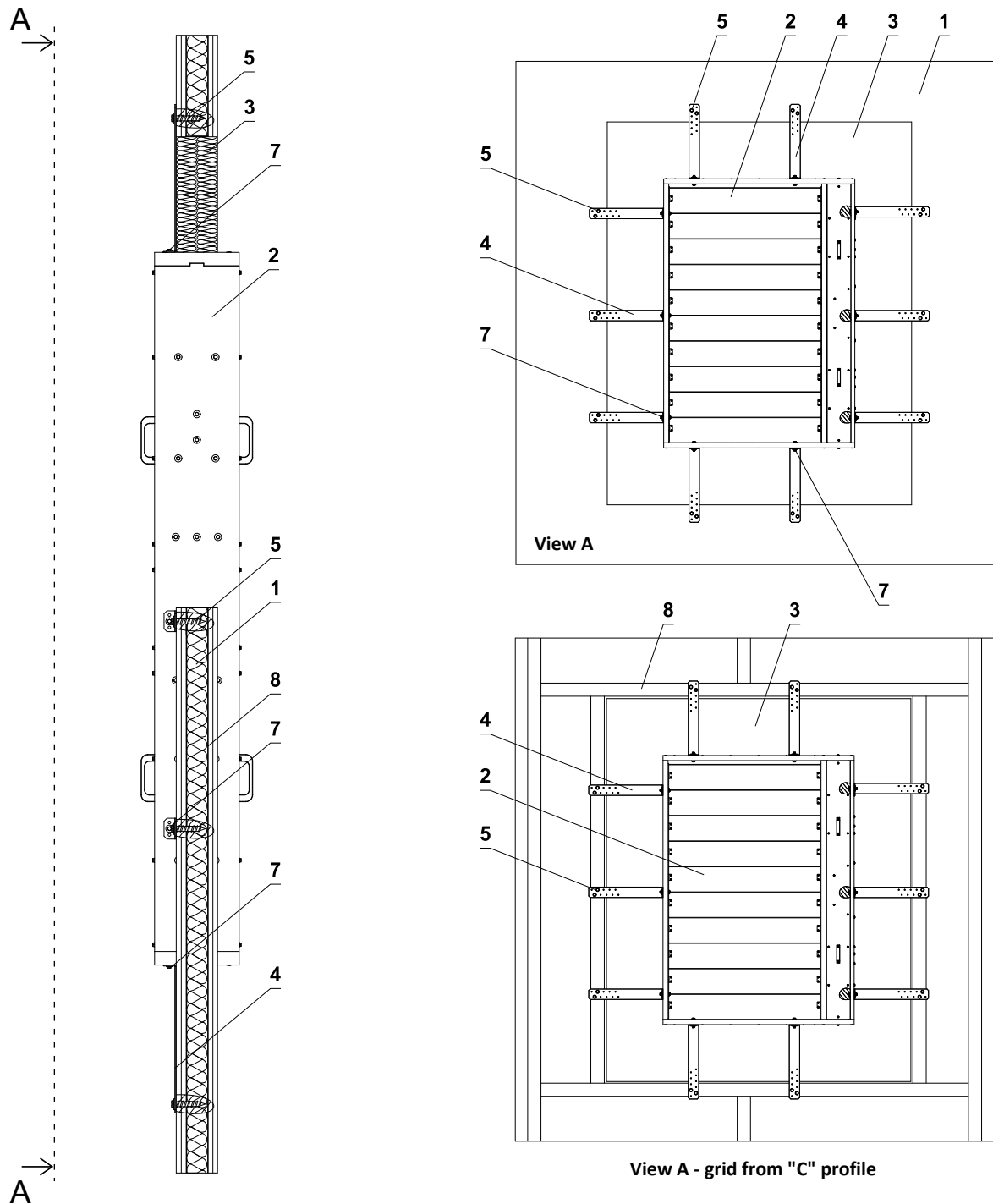

- The method of mounting must meet the minimum requirements for attachment in accordance with national regulations.

**\* RESPECT JOINT POSITION !**

Bolts and nuts shall not prevent free rotation on the blades.

- 1 Gypsum wall construction
- 2 SEDM-L
- 3 Ablative Coated Batt
- 4 Installation holder for connecting damper to the wall (optional accessories MANDIK, a.s. or sheet metal min. thickness 2 mm and min. width 60 mm). Full drawing of bracket, → see page 36
- 5 Screw UNI 6x60 mm
- 6 Installation holes
- 7 M8 bolt assembly (bolt M8x55 mm, 2 pcs large washer M8, nut M8) \*
- 8 Gypsum grid from "C" profile

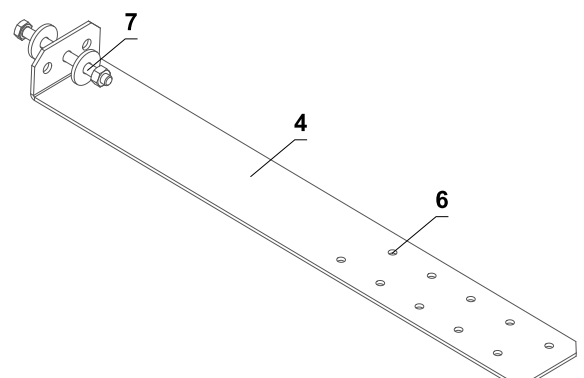

Installation holder for connecting damper to the wall

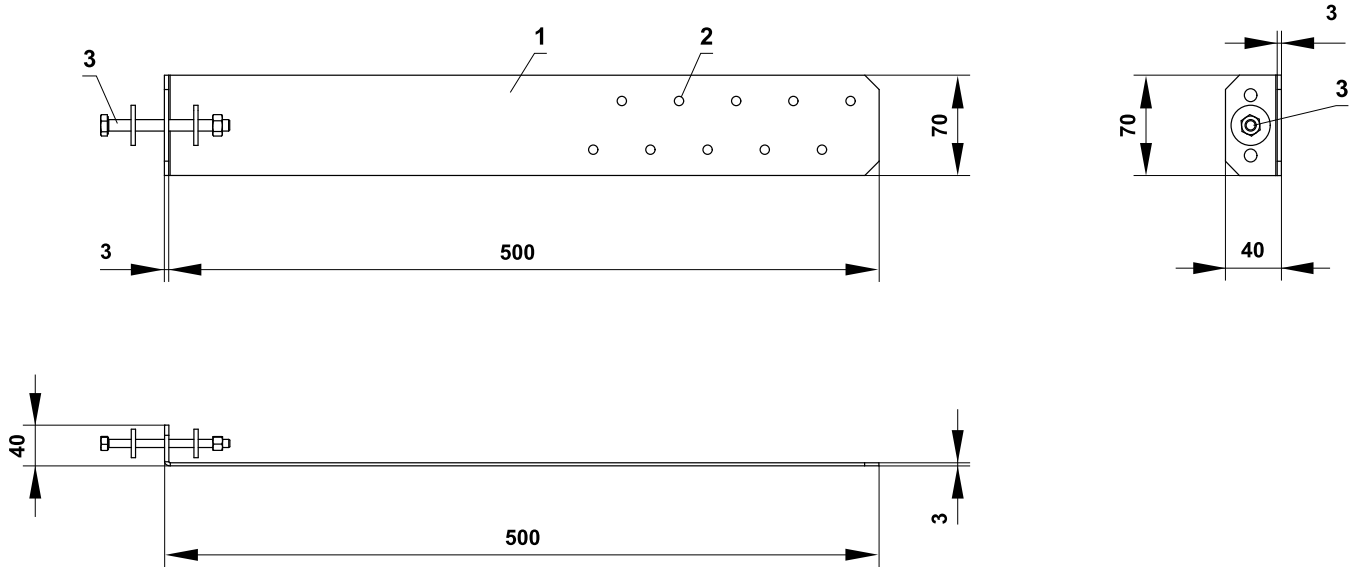

- 1 Installation holder for connecting damper to the wall (optional accessories MANDIK, a.s. or sheet metal min. thickness 2 mm and min. width 60 mm)
- 2 Installation holes
- 3 M8 bolt assembly (bolt M8x55 mm, 2 pcs large washer M8, nut M8)

## Example of duct connection

Example of connection to SHEET STEEL duct

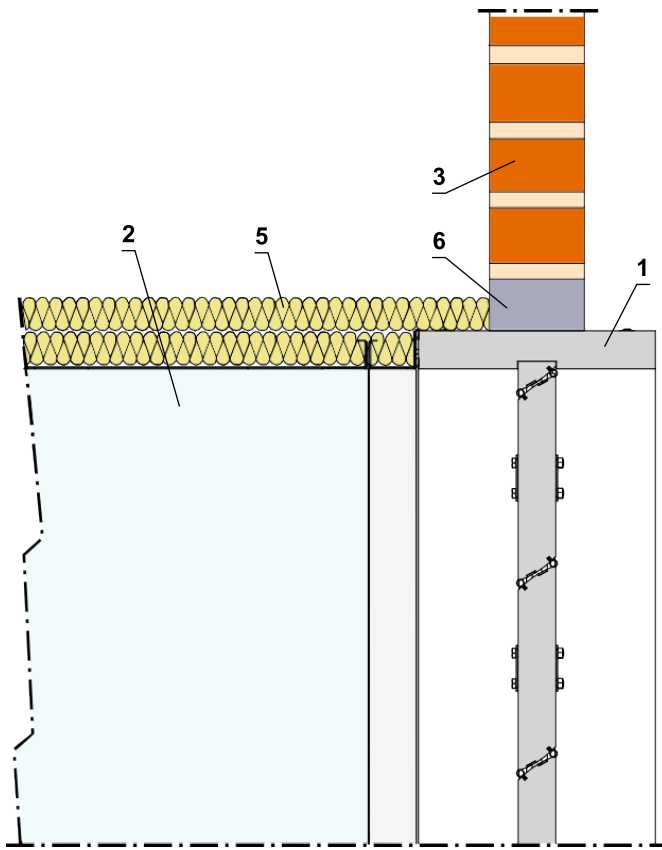

Example of connection to duct made of INSULATION BOARDS

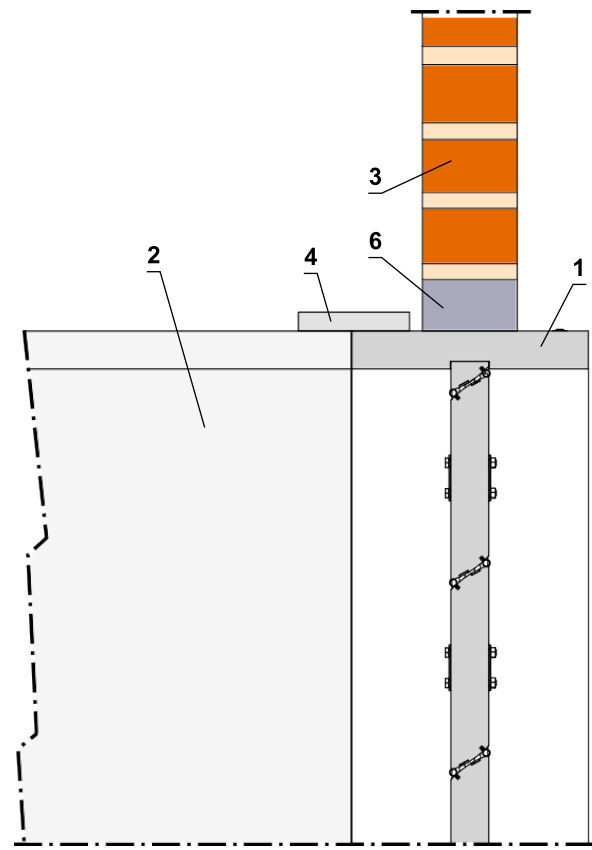

- 1 SEDM-L
- 2 Smoke extraction duct - tested acc.to EN 1366-8 or EN 1366-9
- 3 Fire separating constructions
- 4 Overplating strip - min. th. 30 mm, the same material as a duct.
- 5 Surface protection material (type according to duct manufacturer instructions)
- 6 Penetration seal

# VI. TECHNICAL DATA

## Pressure loss

### Pressure loss calculation

$$\Delta p = \xi \cdot \rho \cdot \frac{w^2}{2}$$

$\Delta p$	[Pa]	pressure loss
$w$	[m/s]	air flow speed in nominal damper section
$\rho$	[kg/m <sup>3</sup> ]	air density
$\xi$	[-]	coefficient of local pressure loss for the nominal damper section → see pages 39 to 42

### Determination of pressure loss by using diagram $\rho = 1,2 \text{ kg/m}^3$

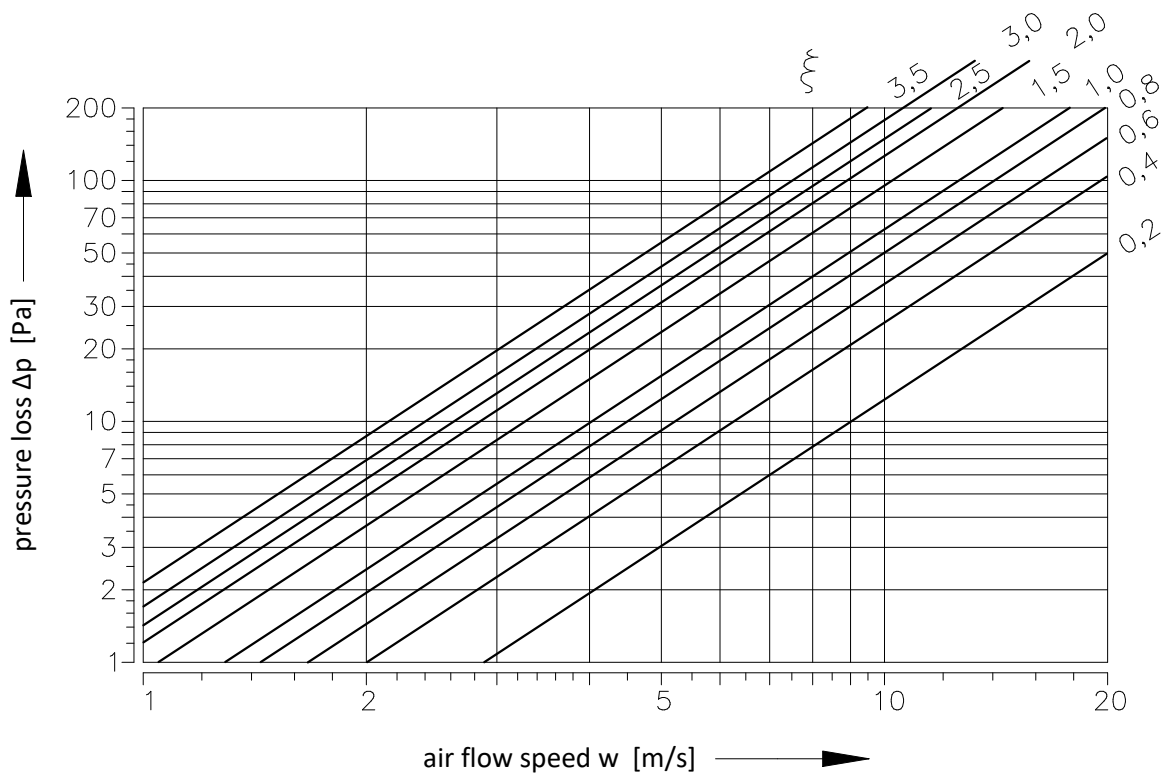

Coefficient of local pressure loss

Installation in duct

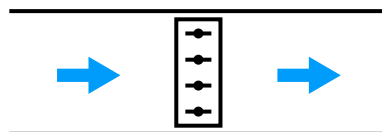

A	B								
	430	630	830	1030	1230	1430	1630	1830	2030
200	0,658	0,586	0,554	0,535	0,523	0,515	0,509	0,504	0,500
250	0,637	0,568	0,536	0,518	0,507	0,499	0,493	0,488	0,484
300	0,624	0,556	0,525	0,508	0,496	0,488	0,482	0,478	0,474
350	0,614	0,548	0,517	0,500	0,489	0,481	0,475	0,471	0,467
400	0,608	0,542	0,512	0,494	0,483	0,476	0,470	0,465	0,462
450	0,602	0,537	0,507	0,490	0,479	0,472	0,466	0,461	0,458
500	0,598	0,533	0,504	0,487	0,476	0,468	0,463	0,458	0,455
550	0,595	0,530	0,501	0,484	0,473	0,466	0,460	0,456	0,452
600	0,592	0,528	0,499	0,482	0,471	0,464	0,458	0,454	0,450
650	0,590	0,526	0,497	0,480	0,469	0,462	0,456	0,452	0,448
700	0,588	0,524	0,495	0,478	0,468	0,460	0,455	0,450	0,447
750	0,586	0,522	0,493	0,477	0,466	0,459	0,453	0,449	0,446
800	0,585	0,521	0,492	0,476	0,465	0,458	0,452	0,448	0,445
850	0,583	0,520	0,491	0,475	0,464	0,457	0,451	0,447	0,444
900	0,582	0,519	0,490	0,474	0,463	0,456	0,450	0,446	0,443
950	0,581	0,518	0,489	0,473	0,462	0,455	0,449	0,445	0,442
1000	0,580	0,517	0,488	0,472	0,462	0,454	0,449	0,444	0,441
1050	0,579	0,516	0,488	0,471	0,461	0,453	0,448	0,444	0,440
1100	0,579	0,516	0,487	0,471	0,460	0,453	0,447	0,443	0,440
1150	0,578	0,515	0,487	0,470	0,460	0,452	0,447	0,443	0,439
1200	0,577	0,515	0,486	0,470	0,459	0,452	0,446	0,442	0,439

Installation at the beginning of duct - without grille

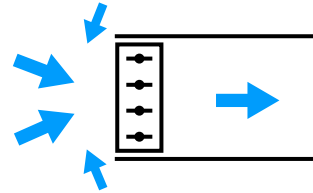

A	B								
	430	630	830	1030	1230	1430	1630	1830	2030
200	1,250	1,114	1,052	1,017	0,994	0,978	0,967	0,958	0,950
250	1,210	1,079	1,019	0,985	0,963	0,947	0,936	0,927	0,920
300	1,185	1,056	0,998	0,964	0,943	0,928	0,916	0,908	0,901
350	1,167	1,041	0,983	0,950	0,929	0,914	0,903	0,894	0,888
400	1,154	1,029	0,972	0,939	0,918	0,904	0,893	0,884	0,878
450	1,144	1,020	0,964	0,931	0,911	0,896	0,885	0,877	0,870
500	1,137	1,013	0,957	0,925	0,904	0,890	0,879	0,871	0,864
550	1,130	1,008	0,952	0,920	0,899	0,885	0,874	0,866	0,859
600	1,125	1,003	0,947	0,916	0,895	0,881	0,870	0,862	0,855
650	1,121	0,999	0,944	0,912	0,891	0,877	0,867	0,858	0,852
700	1,117	0,996	0,940	0,909	0,888	0,874	0,864	0,856	0,849
750	1,113	0,993	0,938	0,906	0,886	0,872	0,861	0,853	0,847
800	1,111	0,990	0,935	0,904	0,884	0,869	0,859	0,851	0,845
850	1,108	0,988	0,933	0,902	0,882	0,868	0,857	0,849	0,843
900	1,106	0,986	0,931	0,900	0,880	0,866	0,855	0,847	0,841
950	1,104	0,984	0,930	0,898	0,878	0,864	0,854	0,846	0,839
1000	1,102	0,983	0,928	0,897	0,877	0,863	0,852	0,844	0,838
1050	1,101	0,981	0,927	0,896	0,876	0,862	0,851	0,843	0,837
1100	1,099	0,980	0,926	0,895	0,875	0,860	0,850	0,842	0,836
1150	1,098	0,979	0,924	0,893	0,873	0,859	0,849	0,841	0,835
1200	1,097	0,978	0,923	0,893	0,872	0,858	0,848	0,840	0,834

Installation at the beginning of duct - with grille

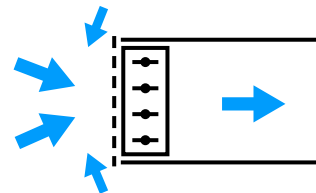

A	B								
	430	630	830	1030	1230	1430	1630	1830	2030
200	2,350	2,214	2,152	2,117	2,094	2,078	2,067	2,058	2,050
250	2,310	2,179	2,119	2,085	2,063	2,047	2,036	2,027	2,020
300	2,285	2,156	2,098	2,064	2,043	2,028	2,016	2,008	2,001
350	2,267	2,141	2,083	2,050	2,029	2,014	2,003	1,994	1,988
400	2,254	2,129	2,072	2,039	2,018	2,004	1,993	1,984	1,978
450	2,244	2,120	2,064	2,031	2,011	1,996	1,985	1,977	1,970
500	2,237	2,113	2,057	2,025	2,004	1,990	1,979	1,971	1,964
550	2,230	2,108	2,052	2,020	1,999	1,985	1,974	1,966	1,959
600	2,225	2,103	2,047	2,016	1,995	1,981	1,970	1,962	1,955
650	2,221	2,099	2,044	2,012	1,991	1,977	1,967	1,958	1,952
700	2,217	2,096	2,040	2,009	1,988	1,974	1,964	1,956	1,949
750	2,213	2,093	2,038	2,006	1,986	1,972	1,961	1,953	1,947
800	2,211	2,090	2,035	2,004	1,984	1,969	1,959	1,951	1,945
850	2,208	2,088	2,033	2,002	1,982	1,968	1,957	1,949	1,943
900	2,206	2,086	2,031	2,000	1,980	1,966	1,955	1,947	1,941
950	2,204	2,084	2,030	1,998	1,978	1,964	1,954	1,946	1,939
1000	2,202	2,083	2,028	1,997	1,977	1,963	1,952	1,944	1,938
1050	2,201	2,081	2,027	1,996	1,976	1,962	1,951	1,943	1,937
1100	2,199	2,080	2,026	1,995	1,975	1,960	1,950	1,942	1,936
1150	2,198	2,079	2,024	1,993	1,973	1,959	1,949	1,941	1,935
1200	2,197	2,078	2,023	1,993	1,972	1,958	1,948	1,940	1,934

Installation at the beginning of duct in the wall - without grille

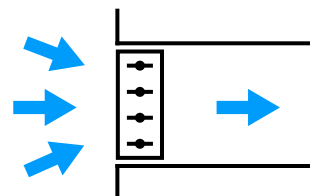

A	B								
	430	630	830	1030	1230	1430	1630	1830	2030
200	1,151	1,026	0,969	0,937	0,916	0,901	0,890	0,882	0,875
250	1,115	0,994	0,939	0,907	0,887	0,873	0,862	0,854	0,848
300	1,091	0,973	0,919	0,888	0,868	0,854	0,844	0,836	0,830
350	1,075	0,958	0,905	0,875	0,855	0,842	0,832	0,824	0,818
400	1,063	0,948	0,895	0,865	0,846	0,832	0,822	0,815	0,808
450	1,054	0,940	0,888	0,858	0,839	0,825	0,815	0,808	0,802
500	1,047	0,933	0,882	0,852	0,833	0,820	0,810	0,802	0,796
550	1,041	0,928	0,877	0,847	0,828	0,815	0,805	0,798	0,792
600	1,036	0,924	0,872	0,843	0,824	0,811	0,801	0,794	0,788
650	1,032	0,920	0,869	0,840	0,821	0,808	0,798	0,791	0,785
700	1,029	0,917	0,866	0,837	0,818	0,805	0,796	0,788	0,782
750	1,026	0,914	0,864	0,835	0,816	0,803	0,793	0,786	0,780
800	1,023	0,912	0,861	0,833	0,814	0,801	0,791	0,784	0,778
850	1,021	0,910	0,859	0,831	0,812	0,799	0,789	0,782	0,776
900	1,019	0,908	0,858	0,829	0,810	0,797	0,788	0,780	0,775
950	1,017	0,906	0,856	0,828	0,809	0,796	0,786	0,779	0,773
1000	1,015	0,905	0,855	0,826	0,808	0,795	0,785	0,778	0,772
1050	1,014	0,904	0,854	0,825	0,807	0,794	0,784	0,777	0,771
1100	1,012	0,903	0,853	0,824	0,805	0,793	0,783	0,776	0,770
1150	1,011	0,901	0,851	0,823	0,805	0,792	0,782	0,775	0,769
1200	1,010	0,900	0,851	0,822	0,804	0,791	0,781	0,774	0,768

Installation at the beginning of duct in the wall - with grille

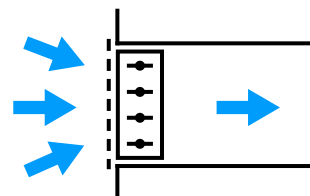

A	B								
	430	630	830	1030	1230	1430	1630	1830	2030
200	2,251	2,126	2,069	2,037	2,016	2,001	1,990	1,982	1,975
250	2,215	2,094	2,039	2,007	1,987	1,973	1,962	1,954	1,948
300	2,191	2,073	2,019	1,988	1,968	1,954	1,944	1,936	1,930
350	2,175	2,058	2,005	1,975	1,955	1,942	1,932	1,924	1,918
400	2,163	2,048	1,995	1,965	1,946	1,932	1,922	1,915	1,908
450	2,154	2,040	1,988	1,958	1,939	1,925	1,915	1,908	1,902
500	2,147	2,033	1,982	1,952	1,933	1,920	1,910	1,902	1,896
550	2,141	2,028	1,977	1,947	1,928	1,915	1,905	1,898	1,892
600	2,136	2,024	1,972	1,943	1,924	1,911	1,901	1,894	1,888
650	2,132	2,020	1,969	1,940	1,921	1,908	1,898	1,891	1,885
700	2,129	2,017	1,966	1,937	1,918	1,905	1,896	1,888	1,882
750	2,126	2,014	1,964	1,935	1,916	1,903	1,893	1,886	1,880
800	2,123	2,012	1,961	1,933	1,914	1,901	1,891	1,884	1,878
850	2,121	2,010	1,959	1,931	1,912	1,899	1,889	1,882	1,876
900	2,119	2,008	1,958	1,929	1,910	1,897	1,888	1,880	1,875
950	2,117	2,006	1,956	1,928	1,909	1,896	1,886	1,879	1,873
1000	2,115	2,005	1,955	1,926	1,908	1,895	1,885	1,878	1,872
1050	2,114	2,004	1,954	1,925	1,907	1,894	1,884	1,877	1,871
1100	2,112	2,003	1,953	1,924	1,905	1,893	1,883	1,876	1,870
1150	2,111	2,001	1,951	1,923	1,905	1,892	1,882	1,875	1,869
1200	2,110	2,000	1,951	1,922	1,904	1,891	1,881	1,874	1,868

Installation in the wall between the rooms - 1 grille

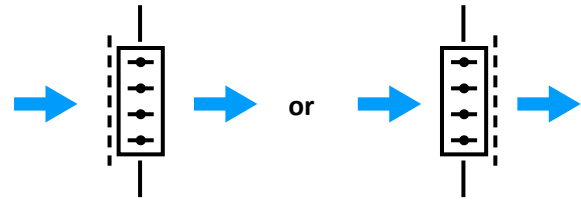

A	B								
	430	630	830	1030	1230	1430	1630	1830	2030
200	3,994	3,680	3,537	3,456	3,403	3,366	3,339	3,318	3,301
250	3,903	3,599	3,460	3,381	3,330	3,294	3,268	3,247	3,231
300	3,844	3,546	3,411	3,333	3,283	3,248	3,222	3,202	3,187
350	3,803	3,510	3,376	3,300	3,251	3,216	3,191	3,171	3,156
400	3,773	3,483	3,351	3,276	3,227	3,193	3,168	3,148	3,133
450	3,750	3,463	3,332	3,257	3,209	3,175	3,150	3,131	3,115
500	3,732	3,446	3,316	3,242	3,194	3,160	3,136	3,117	3,101
550	3,717	3,433	3,304	3,230	3,182	3,149	3,124	3,105	3,090
600	3,705	3,422	3,294	3,220	3,173	3,139	3,115	3,096	3,081
650	3,695	3,413	3,285	3,212	3,165	3,131	3,107	3,088	3,073
700	3,686	3,405	3,278	3,205	3,158	3,125	3,100	3,081	3,067
750	3,679	3,399	3,271	3,199	3,152	3,119	3,094	3,076	3,061
800	3,672	3,393	3,266	3,193	3,146	3,114	3,089	3,071	3,056
850	3,666	3,388	3,261	3,189	3,142	3,109	3,085	3,066	3,051
900	3,661	3,383	3,257	3,184	3,138	3,105	3,081	3,062	3,048
950	3,657	3,379	3,253	3,181	3,134	3,101	3,077	3,059	3,044
1000	3,652	3,375	3,249	3,177	3,131	3,098	3,074	3,056	3,041
1050	3,649	3,372	3,246	3,174	3,128	3,095	3,071	3,053	3,038
1100	3,645	3,369	3,243	3,172	3,125	3,093	3,069	3,050	3,036
1150	3,642	3,366	3,241	3,169	3,123	3,090	3,066	3,048	3,033
1200	3,640	3,364	3,239	3,167	3,121	3,088	3,064	3,046	3,031

Installation in the wall between the rooms - 2 grille

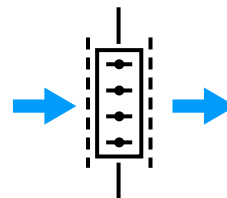

A	B								
	430	630	830	1030	1230	1430	1630	1830	2030
200	4,894	4,580	4,437	4,356	4,303	4,266	4,239	4,218	4,201
250	4,803	4,499	4,360	4,281	4,230	4,194	4,168	4,147	4,131
300	4,744	4,446	4,311	4,233	4,183	4,148	4,122	4,102	4,087
350	4,703	4,410	4,276	4,200	4,151	4,116	4,091	4,071	4,056
400	4,673	4,383	4,251	4,176	4,127	4,093	4,068	4,048	4,033
450	4,650	4,363	4,232	4,157	4,109	4,075	4,050	4,031	4,015
500	4,632	4,346	4,216	4,142	4,094	4,060	4,036	4,017	4,001
550	4,617	4,333	4,204	4,130	4,082	4,049	4,024	4,005	3,990
600	4,605	4,322	4,194	4,120	4,073	4,039	4,015	3,996	3,981
650	4,595	4,313	4,185	4,112	4,065	4,031	4,007	3,988	3,973
700	4,586	4,305	4,178	4,105	4,058	4,025	4,000	3,981	3,967
750	4,579	4,299	4,171	4,099	4,052	4,019	3,994	3,976	3,961
800	4,572	4,293	4,166	4,093	4,046	4,014	3,989	3,971	3,956
850	4,566	4,288	4,161	4,089	4,042	4,009	3,985	3,966	3,951
900	4,561	4,283	4,157	4,084	4,038	4,005	3,981	3,962	3,948
950	4,557	4,279	4,153	4,081	4,034	4,001	3,977	3,959	3,944
1000	4,552	4,275	4,149	4,077	4,031	3,998	3,974	3,956	3,941
1050	4,549	4,272	4,146	4,074	4,028	3,995	3,971	3,953	3,938
1100	4,545	4,269	4,143	4,072	4,025	3,993	3,969	3,950	3,936
1150	4,542	4,266	4,141	4,069	4,023	3,990	3,966	3,948	3,933
1200	4,540	4,264	4,139	4,067	4,021	3,988	3,964	3,946	3,931

## Noise data - level of acoustic output corrected with filter A

Air velocity 2 m/s Level of acoustic output [dB]									
A	B								
	430	630	830	1030	1230	1430	1630	1830	2030
200	27	28	29	30	30	31	31	32	32
250	28	29	30	30	31	32	32	33	33
300	28	29	30	31	32	32	33	33	34
350	29	30	31	32	32	33	33	34	34
400	29	30	31	32	33	33	34	34	35
450	30	31	32	33	33	34	34	35	35
500	30	31	32	33	34	34	35	35	36
550	31	32	33	33	34	35	35	36	36
600	31	32	33	34	34	35	36	36	36
650	31	32	33	34	35	35	36	36	37
700	32	33	34	34	35	36	36	37	37
750	32	33	34	35	35	36	36	37	37
800	32	33	34	35	36	36	37	37	38
850	32	34	34	35	36	36	37	37	38
900	33	34	35	35	36	37	37	38	38
950	33	34	35	36	36	37	37	38	38
1000	33	34	35	36	37	37	38	38	39
1050	33	34	35	36	37	37	38	38	39
1100	34	35	36	36	37	38	38	39	39
1150	34	35	36	36	37	38	38	39	39
1200	34	35	36	37	37	38	38	39	39

Air velocity 3 m/s Level of acoustic output [dB]									
A	B								
	430	630	830	1030	1230	1430	1630	1830	2030
200	36	37	38	39	39	40	40	41	41
250	37	38	39	39	40	41	41	42	42
300	37	38	39	40	41	41	42	42	43
350	38	39	40	41	41	42	42	43	43
400	38	39	40	41	42	42	43	43	44
450	39	40	41	42	42	43	43	44	44
500	39	40	41	42	43	43	44	44	45
550	40	41	42	42	43	44	44	45	45
600	40	41	42	43	43	44	45	45	45
650	40	41	42	43	44	44	45	45	46
700	41	42	43	43	44	45	45	46	46
750	41	42	43	44	44	45	45	46	46
800	41	42	43	44	45	45	46	46	47
850	41	43	43	44	45	45	46	46	47
900	42	43	44	44	45	46	46	47	47
950	42	43	44	45	45	46	46	47	47
1000	42	43	44	45	46	46	47	47	48
1050	42	43	44	45	46	46	47	47	48
1100	43	44	45	45	46	47	47	48	48
1150	43	44	45	45	46	47	47	48	48
1200	43	44	45	46	46	47	47	48	48

**Air velocity 4 m/s  
Level of acoustic output [dB]**

A	B								
	430	630	830	1030	1230	1430	1630	1830	2030
200	42	43	44	45	46	47	47	47	48
250	43	44	45	46	47	47	48	48	49
300	44	45	46	47	47	48	49	49	49
350	44	46	47	47	48	49	49	50	50
400	45	46	47	48	49	49	50	50	51
450	45	47	48	48	49	50	50	51	51
500	46	47	48	49	50	50	51	51	52
550	46	47	48	49	50	51	51	52	52
600	47	48	49	50	50	51	51	52	52
650	47	48	49	50	51	51	52	52	53
700	47	48	49	50	51	52	52	53	53
750	48	49	50	51	51	52	52	53	53
800	48	49	50	51	51	52	53	53	53
850	48	49	50	51	52	52	53	53	54
900	48	50	50	51	52	53	53	54	54
950	49	50	51	52	52	53	53	54	54
1000	49	50	51	52	52	53	54	54	54
1050	49	50	51	52	53	53	54	54	55
1100	49	50	51	52	53	53	54	54	55
1150	49	51	52	52	53	54	54	55	55
1200	50	51	52	53	53	54	54	55	55

**Air velocity 5 m/s  
Level of acoustic output [dB]**

A	B								
	430	630	830	1030	1230	1430	1630	1830	2030
200	49	50	51	52	53	54	54	54	55
250	50	51	52	53	54	54	55	55	56
300	51	52	53	54	54	55	56	56	56
350	51	53	54	54	55	56	56	57	57
400	52	53	54	55	56	56	57	57	58
450	52	54	55	55	56	57	57	58	58
500	53	54	55	56	57	57	58	58	59
550	53	54	55	56	57	58	58	59	59
600	54	55	56	57	57	58	58	59	59
650	54	55	56	57	58	58	59	59	60
700	54	55	56	57	58	59	59	60	60
750	55	56	57	58	58	59	59	60	60
800	55	56	57	58	58	59	60	60	60
850	55	56	57	58	59	59	60	60	61
900	55	57	57	58	59	60	60	61	61
950	56	57	58	59	59	60	60	61	61
1000	56	57	58	59	59	60	61	61	61
1050	56	57	58	59	60	60	61	61	62
1100	56	57	58	59	60	60	61	61	62
1150	56	58	59	59	60	61	61	62	62
1200	57	58	59	60	60	61	61	62	62

**Air velocity 6 m/s  
Level of acoustic output [dB]**

A	B								
	430	630	830	1030	1230	1430	1630	1830	2030
200	54	55	56	57	58	58	59	59	60
250	55	56	57	58	59	59	60	60	61
300	55	57	58	59	59	60	60	61	61
350	56	57	58	59	60	60	61	61	62
400	57	58	59	60	60	61	62	62	62
450	57	58	59	60	61	62	62	63	63
500	57	59	60	61	61	62	62	63	63
550	58	59	60	61	62	62	63	63	64
600	58	60	61	61	62	63	63	64	64
650	59	60	61	62	62	63	64	64	64
700	59	60	61	62	63	63	64	64	65
750	59	60	61	62	63	64	64	65	65
800	59	61	62	63	63	64	64	65	65
850	60	61	62	63	64	64	65	65	66
900	60	61	62	63	64	64	65	65	66
950	60	61	62	63	64	65	65	66	66
1000	60	62	63	64	64	65	65	66	66
1050	61	62	63	64	64	65	66	66	67
1100	61	62	63	64	65	65	66	66	67
1150	61	62	63	64	65	65	66	66	67
1200	61	62	63	64	65	66	66	67	67

**Air velocity 8 m/s  
Level of acoustic output [dB]**

A	B								
	430	630	830	1030	1230	1430	1630	1830	2030
200	60	62	63	64	64	65	66	66	66
250	61	63	64	65	65	66	66	67	67
300	62	63	64	65	66	67	67	68	68
350	63	64	65	66	67	67	68	68	69
400	63	65	66	67	67	68	68	69	69
450	64	65	66	67	68	68	69	69	70
500	64	66	67	67	68	69	69	70	70
550	65	66	67	68	69	69	70	70	71
600	65	66	67	68	69	70	70	71	71
650	65	67	68	69	69	70	70	71	71
700	66	67	68	69	70	70	71	71	72
750	66	67	68	69	70	71	71	72	72
800	66	68	69	69	70	71	71	72	72
850	66	68	69	70	70	71	72	72	73
900	67	68	69	70	71	71	72	72	73
950	67	68	69	70	71	72	72	73	73
1000	67	68	70	70	71	72	72	73	73
1050	67	69	70	71	71	72	73	73	73
1100	67	69	70	71	72	72	73	73	74
1150	68	69	70	71	72	72	73	73	74
1200	68	69	70	71	72	73	73	74	74

**Air velocity 10 m/s  
Level of acoustic output [dB]**

A	B								
	430	630	830	1030	1230	1430	1630	1830	2030
200	66	68	69	70	70	71	72	72	72
250	67	69	70	71	71	72	72	73	73
300	68	69	70	71	72	73	73	74	74
350	68	70	71	72	73	73	74	74	75
400	69	71	72	72	73	74	74	75	75
450	70	71	72	73	74	74	75	75	76
500	70	71	73	73	74	75	75	76	76
550	70	72	73	74	75	75	76	76	77
600	71	72	73	74	75	76	76	77	77
650	71	73	74	75	75	76	76	77	77
700	71	73	74	75	76	76	77	77	78
750	72	73	74	75	76	77	77	78	78
800	72	73	75	75	76	77	77	78	78
850	72	74	75	76	76	77	78	78	79
900	72	74	75	76	77	77	78	78	79
950	73	74	75	76	77	78	78	79	79
1000	73	74	76	76	77	78	78	79	79
1050	73	75	76	77	77	78	79	79	79
1100	73	75	76	77	78	78	79	79	80
1150	74	75	76	77	78	78	79	79	80
1200	74	75	76	77	78	79	79	80	80

**Air velocity 12 m/s  
Level of acoustic output [dB]**

A	B								
	430	630	830	1030	1230	1430	1630	1830	2030
200	71	73	74	75	75	76	76	77	77
250	72	73	75	75	76	77	77	78	78
300	73	74	75	76	77	78	78	79	79
350	73	75	76	77	78	78	79	79	80
400	74	75	77	77	78	79	79	80	80
450	74	76	77	78	79	79	80	80	81
500	75	76	77	78	79	80	80	81	81
550	75	77	78	79	80	80	81	81	82
600	76	77	78	79	80	81	81	82	82
650	76	77	79	79	80	81	81	82	82
700	76	78	79	80	81	81	82	82	83
750	77	78	79	80	81	81	82	83	83
800	77	78	79	80	81	82	82	83	83
850	77	79	80	81	81	82	83	83	84
900	77	79	80	81	82	82	83	83	84
950	78	79	80	81	82	82	83	84	84
1000	78	79	80	81	82	83	83	84	84
1050	78	80	81	82	82	83	83	84	84
1100	78	80	81	82	82	83	84	84	85
1150	78	80	81	82	83	83	84	84	85
1200	79	80	81	82	83	84	84	85	85

## VII. MATERIAL, FINISHING

- Damper casings and blades are made of fire resistant asbestos free boards made of mineral fibres.
- Damper bodies and blades can be coated with Promat 2000 anti-moisture coating or Promat-SR anti-aggressive coating.
- Fasteners are galvanized.
- Any other requirements for the design shall be considered atypical and shall be addressed on an individual basis.

## VIII. TRANSPORTATION, STORAGE AND WARRANTY

### Logistic terms

- Dampers are delivered on special pallets. As standard, the dampers are wrapped in plastic foil for protection during transport and must not be used for long-term storage of the equipment. Changes in temperature during transport may cause condensation of water vapour inside the packaging and thereby conditions may arise inside the packaging that are suitable for corrosion of materials used in the equipment (e.g. white corrosion on zinc-coated items or mould on calcium silicate). Therefore, it is necessary to remove the transport packaging immediately after unloading to allow air to circulate around the product.
- The equipment must be stored in clean, dry, well ventilated and dust-free environment out of direct sunlight. ensuring protection against moisture and extremes of temperatures (minimum temperature +5°C) the equipment must be protected against mechanical and accidental damage prior to installation.
- Another required packaging system should be approved and agreed by manufacturer. Packaging material is not returnable in case that another packaging system (material) is required and used and it is not included into final price of damper.
- For unloading and further manipulation with the damper is necessary to use appropriate tooling (forklifts) due to damper weight. Dampers are fragile.
- Dampers are transported by box freight vehicles without direct weather impact, there must not occur any shocks and ambient temperature must not exceed +50°C. Dampers must be protected against impact when transported and manipulated. During transportation, the damper blades must be in the "CLOSED" position.
- Dampers are stored indoor in environment without any aggressive vapours, gases or dust. Indoor temperature must be in the range from -30°C to +50°C and maximum relative humidity 95% (avoid condensation on the damper body). Dampers must be protected against impact when transported and manipulated.

### Warranty

- The manufacturer provides a warranty of 24 months from the date of dispatch for the dampers.
- The warranty for fire dampers SEDM-L, provided by the manufacturer, is completely void if actuating, closing and control devices are unprofessionally handled by untrained workers or if electric components, i.e. actuators.
- The warranty is void if dampers are used for other purposes, devices and working conditions than those allowed by these technical conditions or if the dampers are mechanically damaged during handling.
- If the dampers are damaged by transport, a record must be written down with the forwarder at reception for later complaint.

## IX. ASSEMBLY, ATTENDANCE AND MAINTENANCE

- Assembly, maintenance and damper function check can be done only by qualified and trained person, i.e. "AUTHORIZED PERSON" according to the manufacturer documentation. All works done on the smoke control dampers must be done according international and local norms and laws.
- All effective safety standards and directives must be observed during damper assembly.
- To ensure reliable smoke exhaust damper function it is necessary to avoid blocking the closing mechanism and contact surfaces with collected dust, fibre and sticky materials and solvents.
- Manual operation
  - Without power supply, the damper can be operated manually and fixed in any required position.

## Electrical connection of the actuator in protection box

### Protection box without slot or predrilled holes

- Drill two holes into the protection box (from outside to inside) and pull through field wiring cables (CAT 3 fire resistant cables as BS 8519) to connect to the actuator trailing lead inside the housing, using a standard screwed cable connector block, the protection box is made of calcium silicate plates.
- Procedure
  - Use drill (drill size acc. To suit connecting cable  $\varnothing + 2$  mm for seal up by mastic) and make two holes. It is possible to drill holes in any side of the housing.
  - Pull the heat resistant cable through the calcium silicate plate (wall) and connect with cables from actuator acc. to above mentioned electrical diagram.
  - Seal up the space around cable with fire resistant mastic (HILTI CFS-S ACR, PROMASTOP) or equivalent.
  - Let the mastic harden.

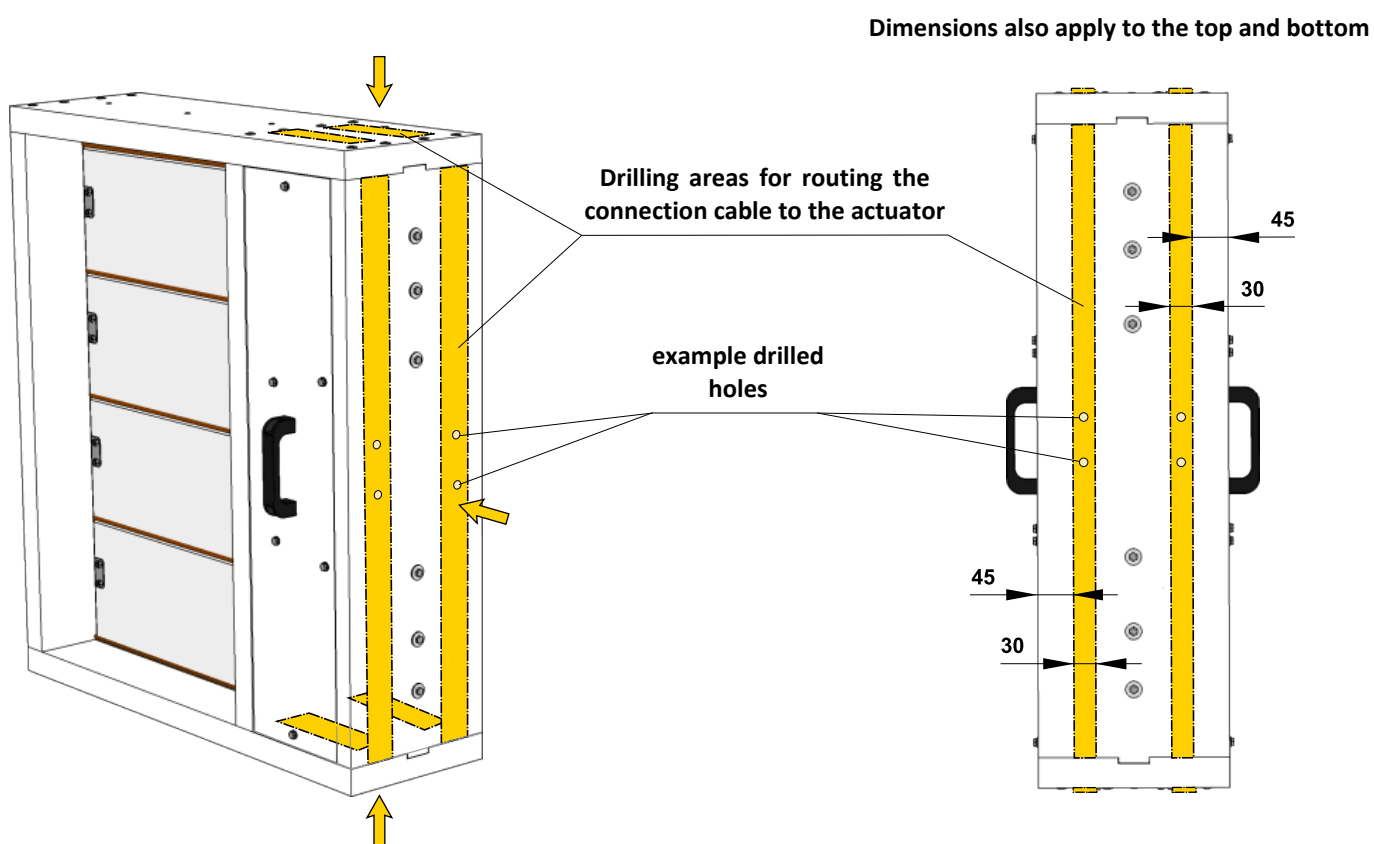

*Example of position of holes in the wall of the box, without pre-manufactured slot*

## Entry into service and revisions

- Before entering the dampers into operation after assembly and after sequential revisions, checks and functionality tests of all designs including operation of the electrical components must be successfully provided and finished. After entering into operation, these revisions must be done according to requirement set by national regulations.
- In case that dampers are found unable to serve for their function for any cause, it must be clearly marked. The operator is obliged to ensure that the damper is put into condition in which it is ready for function and meanwhile he is obliged to provide the fire protection by another appropriate way.
- Removing actuator housing cover (from both sides)
  - Release actuator housing cover by unscrewing all the screws located on the cover.
- Results of regular checks, imperfections found and all-important facts connected with the damper function must be recorded in the "FIRE BOOK" and immediately reported to the operator.
- Before entering the dampers into operation after their assembly and by sequential checks, the following checks must be carried out for all designs.
- Visual inspection of proper damper integration, inside damper area, damper blade, contact surfaces and silicon sealing.

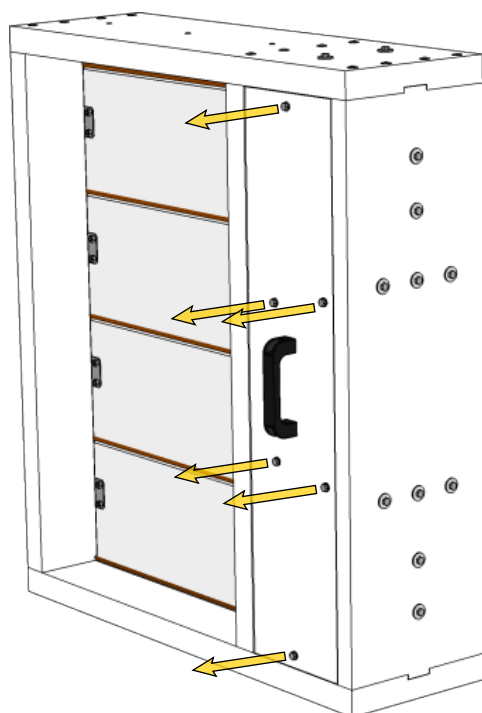

*Actuator housing cover detail*

- Ensure each damper is fully checked for operational capability, control should be initiated from the control system. Dampers blades should open and close correctly and operation should be visually inspected and documented prior to handover.

# X. ORDERING INFORMATION

## Ordering key



**EXAMPLE:**

**SEDM-L EN 1200x2030 .44/M1/P2 Q30-ZN**

Smoke control damper SEDM-L, dimension 1200x2030 mm, control design with spring return actuator AC 230 V, flange and cover grille KMM over blades (on one side), flange over damper (on other side), flange dimension 30 mm, galvanized material variant.

**1 | Type of smoke control damper - SEDM-L**

**2 | Country of destination**

**3 | Damper dimensions A x B → see pages 12 to 14**

„A“ is the width of the damper

„B“ is the height of the damper

**4 | Damper design**

.44	With actuating mechanism BEN, BEE, BE for 230V
.54	With actuating mechanism BEN, BEE, BE for 24V
.65*	With actuating mechanism BEN (BEE)-SR for 24V

\* Design .65 is not available by using actuating mechanism BE.

**5 | Flange/Cover grille KMM (on one side)**

	Without flange and without KMM cover grille
P1	Flange over blades
P2	Flange over damper
M1	Flange and cover grille KMM over blades*
M2	Flange and cover grille KMM over damper*

\* The surface of the cover grille KMM is provided with powder coating, standard colour is the RAL 9010. Requirements for other colour of the cover grille KMM, must be discussed in advance with the manufacturer.

**6 | Flange/Cover grille KMM (on other side)**

	Without flange and without KMM cover grille
P1	Flange over blades
P2	Flange over damper
M1	Flange and cover grille KMM over blades*
M2	Flange and cover grille KMM over damper*

\* The surface of the cover grille KMM is provided with powder coating, standard colour is the RAL 9010. Requirements for other colour of the cover grille KMM, must be discussed in advance with the manufacturer.

**7 | Flange dimension**

Q30	Flange width 30 mm
-----	--------------------

**8 | Material**

ZN	Galvanized
----	------------

**9 | Surface treatment**

	Without surface treatment
IW	Damper blade impregnation, impregnating agent PROMAT 2000 - impregnation against humidity
IA	Damper blade impregnation, impregnating agent PROMAT SR - impregnation against chemical

### Accessories

#### Flange



1| Accessory type - flange

3| Type of smoke control damper - SEDM-L

4| Damper dimensions A x B → see pages 12 to 14

#### 2| Flange design

P1	Flange over blades
P2	Flange over damper

#### Cover grille KMM



1| Accessory type - cover grille KMM

3| Type of smoke control damper - SEDM-L

4| Damper dimensions A x B → see pages 12 to 14

#### 2| Cover grille KMM design\*

M1	Cover grille KMM over blades
M2	Cover grille KMM over damper

\* The surface of the cover grille KMM is provided with powder coating, standard colour is the RAL 9010. Requirements for other colour of the cover grille KMM, must be discussed in advance with the manufacturer.

#### Installation holder



1| Accessory type - installation holder

#### 2| Installation holder design

L = 500	Length 500 mm
L = 250	Length 250 mm

### Data label

- Data label is placed on the damper casing (example)

<b>MANDÍK®</b>		MANDÍK, a.s. Dobříšská 550, 267 24 Hostomice, Czech Republic	
MULTI COMPARTMENT SMOKE CONTROL DAMPER - XXXX			
DIMENSION:		DESIGN:	
SERIAL.NO.:		WEIGHT (kg):	
CLASSIFICATION:			
TPM XXX/XX	Cert. No.: 1391-CPR-XXXX/XXXX, DoP: PM/XXXX/XX/XX/X	XX	EN 12101:2011



MANUAL



The producer reserves the right for innovations of the product.  
For actual product information see [www.mandik.com](http://www.mandik.com)

**MANDÍK**<sup>®</sup>  
[www.mandik.com](http://www.mandik.com)

