

## FDMA-PM

### Fire damper

Technical Documentation

Installation, Commissioning, Operation, Maintenance and Service Manual

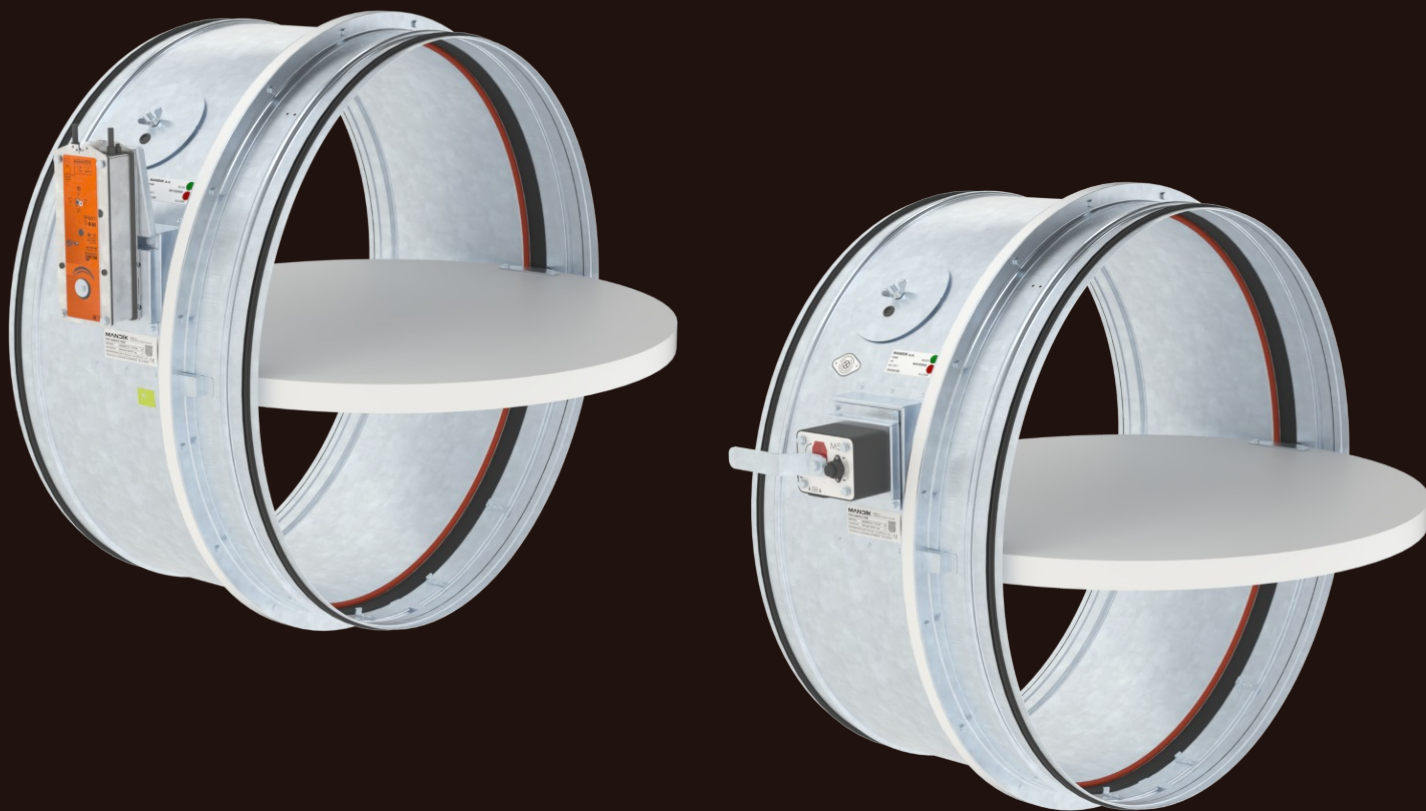

CE  
1391

MANDÍK®

[www.mandik.com](http://www.mandik.com)

These technical specifications state a row of manufactured sizes and models of fire dampers FDMA-PM  
It is valid for production, designing, ordering, delivery, maintenance and operation.

# CONTENT

I. GENERAL.....	3
Description.....	3
II. DESIGN.....	4
Design with manual control.....	4
Design with spring return actuator.....	7
Design with the communication and supply device.....	11
III. DIMENSIONS.....	13
Technical parameters.....	15
IV. INSTALLATION.....	16
Placement and installation.....	16
Statement of installations.....	18
Installation in solid wall construction.....	19
Installation outside solid wall construction.....	25
Installation in gypsum wall construction.....	28
Installation outside gypsum wall construction .....	34
Shaft walls.....	37
Installation in solid ceiling construction.....	39
Installation outside solid ceiling construction.....	43
Installation frames.....	45
V. SUSPENSION SYSTEMS.....	46
Example of duct connection.....	47
VI. TECHNICAL DATA.....	48
Pressure loss.....	48
Noise data.....	49
VII. MATERIAL, FINISHING.....	50
VIII. TRANSPORTATION, STORAGE AND WARRANTY.....	51
Logistic terms.....	51
Warranty.....	51
IX. ASSEMBLY, ATTENDANCE AND MAINTENANCE.....	52
Commissioning and revisions.....	54
X. ORDERING INFORMATIONS.....	56
Ordering key.....	56
Accessories.....	57
Data label.....	58

# I. GENERAL

## Description

Fire dampers are shutters in ducts of air-conditioning devices that prevent the spread of fire and combustion products from one fire segment to the other one by means of closing the duct in the points of fire separating constructions.

Damper blade automatically closes air duct using a closing spring or a spring return actuator. The closing spring is actuated by pressing a button on the manual control or by melting a thermal fuse.

The return spring of the actuator is actuated when a thermoelectric activation device BAT is activated, when a test button on BAT is pressed or when power supply of the actuator is interrupted.

After closing the blade, the damper is sealed with silicon against smoke penetration. On request by customer, the damper can be supplied silicon-free. In the closed position, the damper is also sealed with material which increases its volume due to increasing temperature and air proofs the air duct.



*FDMA-PM with spring return actuator*



*FDMA-PM with manual control*

### Damper characteristics

- CE certified acc. to EN 15650
- Tested in accordance with EN 1366-2
- Classified acc. to EN 13501-3+A1
- External Casing leakage class min. ATC 3 (old marking "C"), Internal leakage min. class 2 acc. to EN 1751
- Cycling test in class C<sub>10000</sub> acc. to EN 15650
- Corrosion resistant acc. to EN 15650
- Certificate of constancy of performance No. 1391-CPR-XXXX/XXXX
- Declaration of Performance No. PM/FDMA-PM/01/XX/X
- Hygienic assessment of fire dampers - Report No. 1.6/pos/19/19b

### Working conditions

- Exact damper function is provided under the following conditions:
  - maximum air velocity 12 m/s
  - maximum pressure difference 1200 Pa
  - the air circulation in the whole damper section must be secured steady over the entire surface.
- Dampers can be installed in arbitrary position
- Dampers are suitable for systems without abrasive, chemical and adhesive particles.
- Dampers are designed for macroclimatic areas with mild climate according to EN IEC 60 721-3-3 ed.2., class 3K22. (Environment 3K22 is typically protected place with regulated temperature)
- Temperature in the place of installation is permitted to range from -30°C to +50°C.

## II. DESIGN

### Design with manual control

#### Design .01

- Design with manual control with a thermal fuse which actuates the shutting device, after the nominal activation temperature 72°C has been reached.
- Automatic initiation of the manual control is not activated if the temperature does not exceed 70°C.
- In case that other activation temperatures are required, thermal fuses with nominal activation temperature +104°C or +147°C can be supplied (this requirement must be specified in the order).



Design .01

#### Design .11

- Design .01 with manual control can be complemented with a limit switch signaling of the damper blade position "CLOSED".
- Cable is connected directly to limit switch.
- Limit switch detail → see page 6

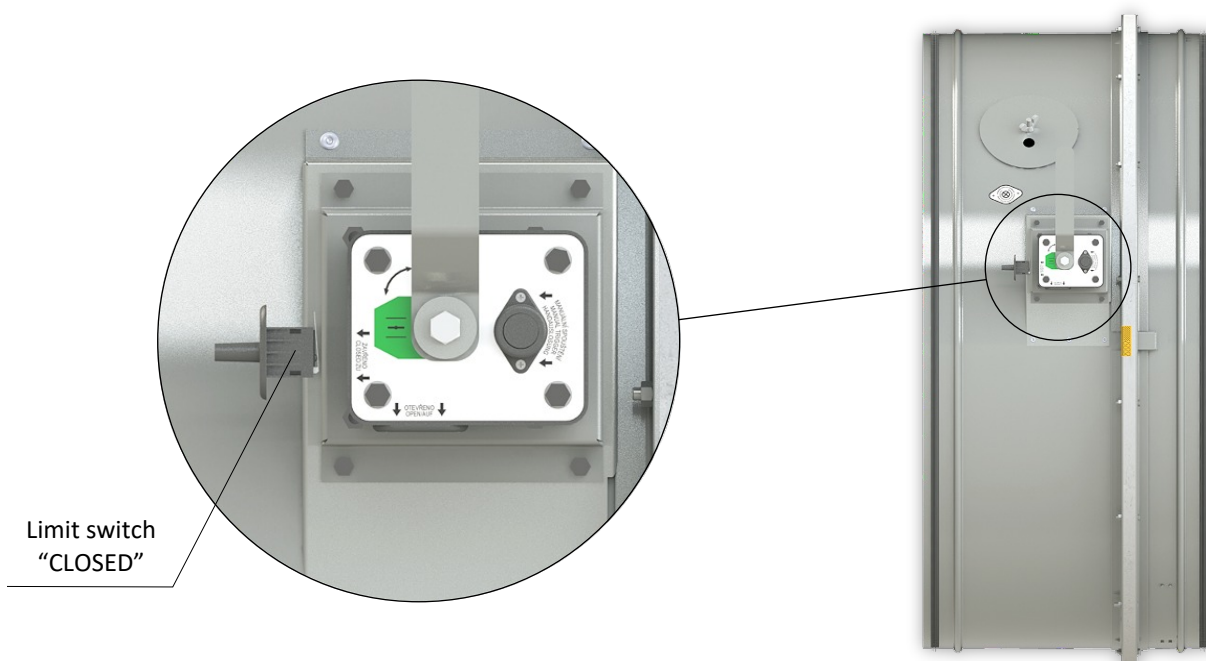

Design .11

**Design .80**

- Design .01 with manual control can be complemented with two limit switches signaling of the damper blade position "CLOSED" and "OPEN".
- Cables are connected directly to limit switches.
- Limit switch detail → see page 6

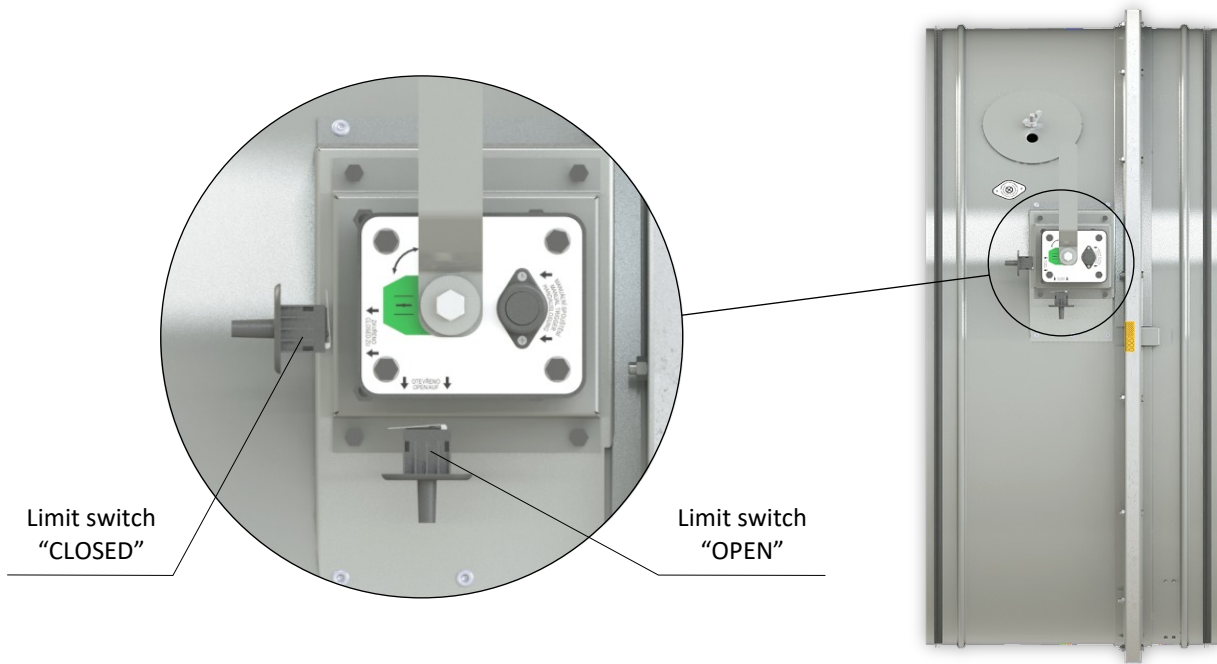

*Design .80*

Manual control

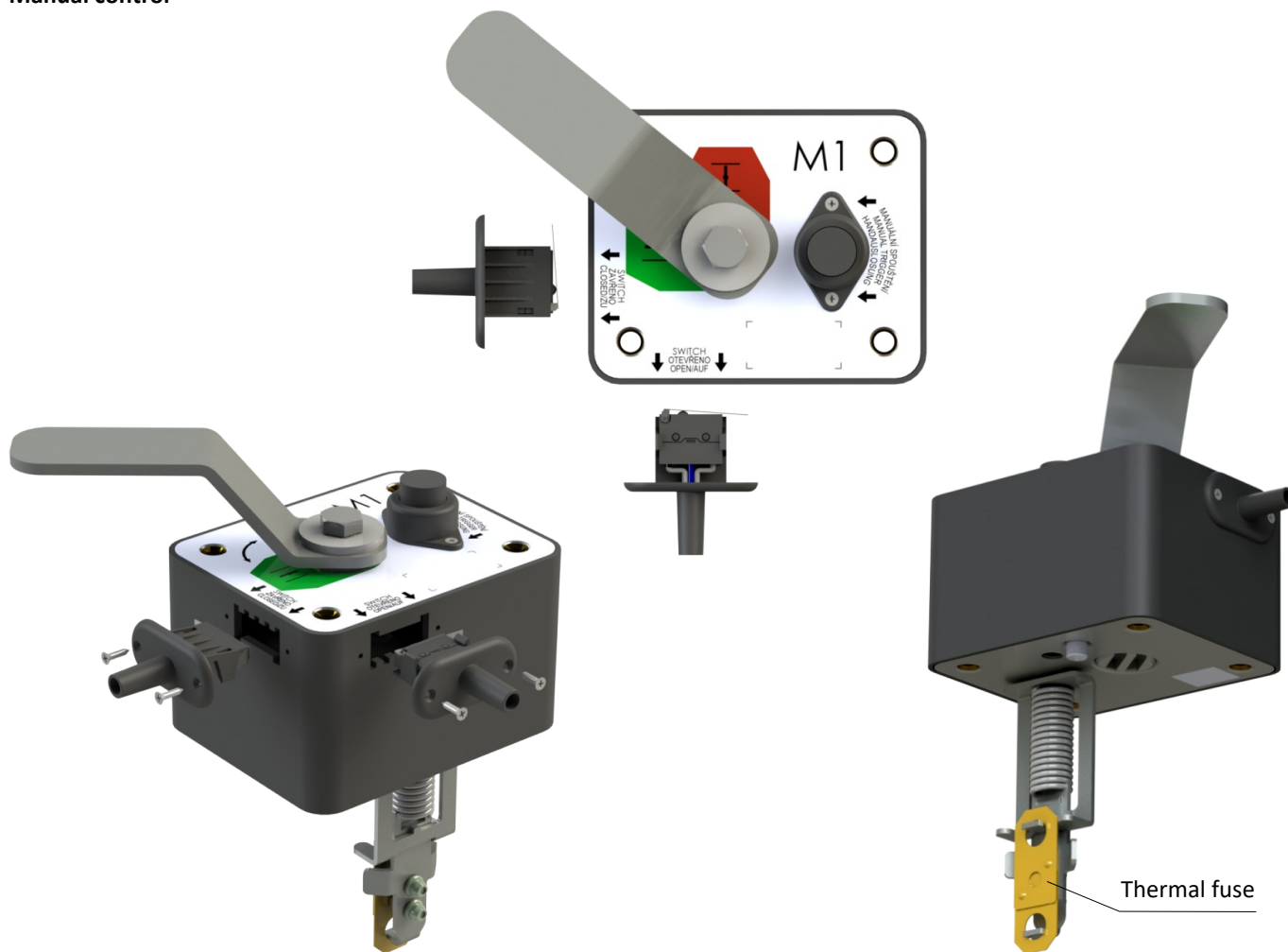

Limit switch G905-300E03W1

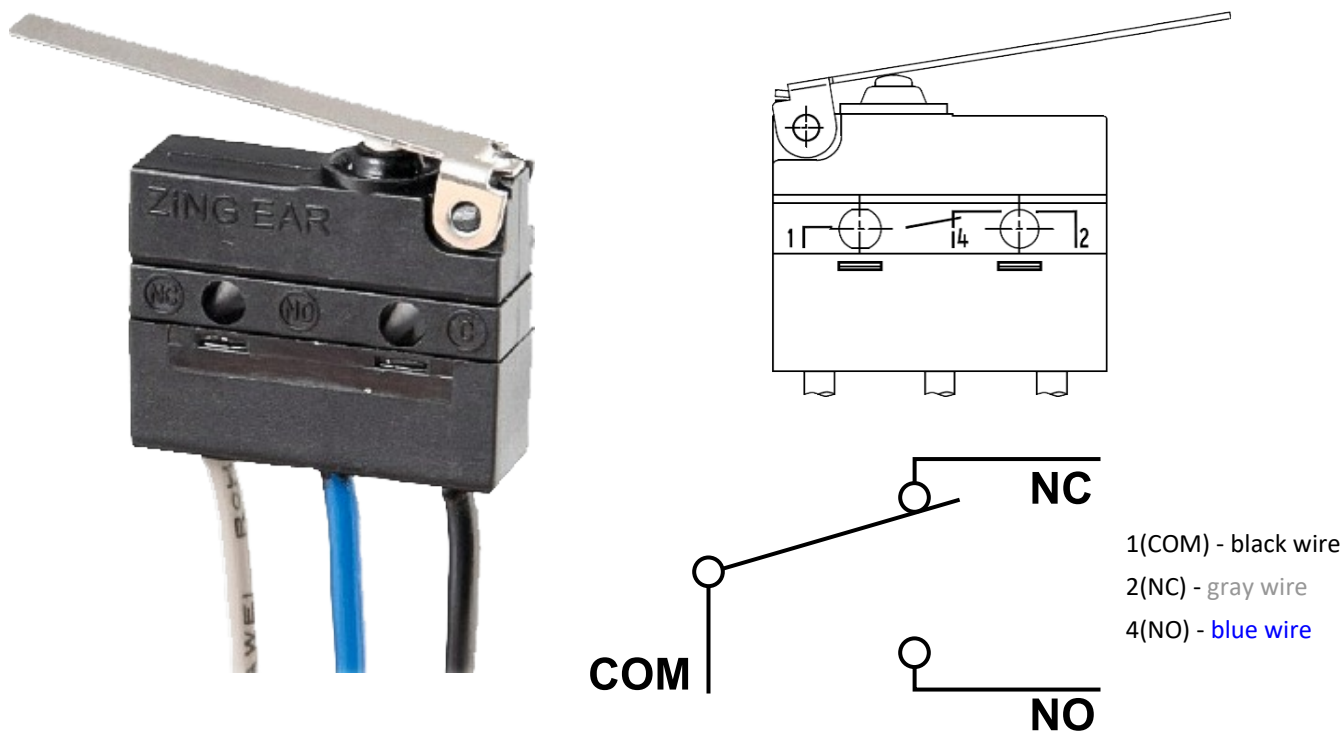

Nominal voltage and maximal current	AC 230V / 5A
Class of protection	IP 67
Working temperature	-25°C ... +120°C

This limit switch is possible to connect in two following ways

- CUT-OFF if the arm is moving ... connect wire 1+2
- SWITCH-ON if the arm is moving ... connect wire 1+4

## Design with spring return actuator

### Design .40 and .50

- The fire dampers are equipped with Belimo spring return actuators with thermoelectric activation device BAT, of series "BF".
- After being connected to power supply 230V or AC/DC 24V, the actuator rotates the damper blade to the operating position "OPEN" and at the same time pre-stretches its return spring.
- When the actuator is power supplied, the damper blade is in the position "OPEN" and the return spring is pre-stretched.
- Time needed for full opening of the damper blade from the position "CLOSED" to the position "OPEN" is maximum 120 sec. If the actuator power supply is interrupted (due to loss of supply voltage, or pressing a test button on the thermoelectric activation device BAT), the actuator rotates the damper blade to the breakdown position "CLOSED".
- The time of closing the damper blade from the position "OPEN" to the position "CLOSED" takes maximum 20 sec.
- In case that the power supply is restored again (the blade can be in any position), the actuator starts to rotate the damper blade back to the position "OPEN".
- A thermoelectric activation device BAT, which contains two thermal fuses Tf1 and Tf2, is an integral part of the actuator.
- These fuses are activated when temperature +72°C has been reached (the fuse Tf1 due to temperature outside the duct and the fuse Tf2 due to temperature inside the duct). The thermoelectric activation device can also be equipped with a Tf2 thermal fuse type ZBAT 95/120/140 (must be specified in the order). In this case, the activation temperature inside the duct is +95°C, +120°C or +140°C (depending on the type).
- After the thermal fuse Tf1 or Tf2 has been activated, the power supply is permanently and irreversibly interrupted and the actuator, by means of the pre-stretched spring, rotates the damper blade into the breakdown position "CLOSED".
- Signalisation of damper blade position "OPEN" and "CLOSE" is provided by two microswitches.

Spring return actuator



*Design .40 and .50*

Actuator BELIMO BF 230-TN

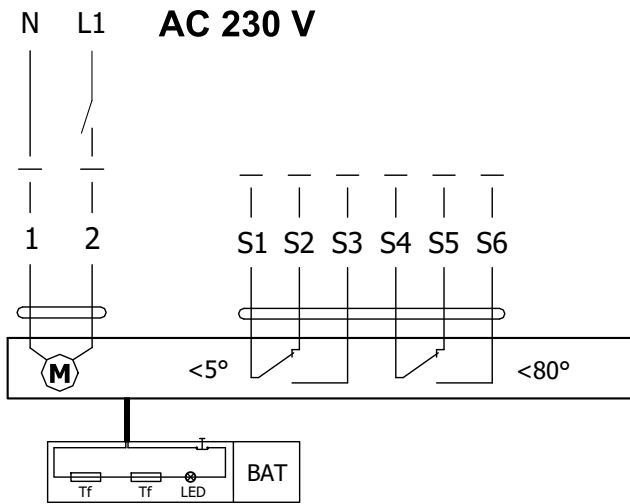

Actuator BELIMO BF 24-TN (-ST)

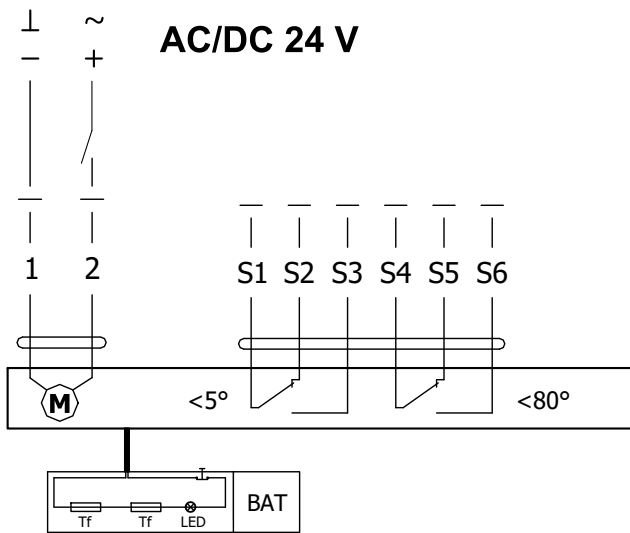

Actuator BELIMO BF 230-TN(-ST), BF 24-TN(-ST)

Actuator BELIMO - 18 Nm/ 12 Nm Spring	BF 230-TN(-ST)	BF 24-TN(-ST)
Power voltage	AC 230 V 50/60Hz	AC/DC 24 V 50/60Hz
Power consumption - in operation - in rest position	8,5 W 3 W	7 W 2 W
Dimensioning	11 VA (I <sub>max</sub> 8,3 A @ 5 ms)	10 VA (I <sub>max</sub> 8,3 A @ 5 ms)
Protection class	II	III
Degree of protection	IP 54	
Running time - motor - spring return	120 s ~ 16 s	
Ambient temperature - normal duty - safety duty - non-operating temperature	-30°C ... +50°C The safe position will be attained up to max. +75°C -40°C ... +50°C	
Connection - supply/control - auxiliary switch	cable 1 m, 2 x 0,75 mm <sup>2</sup> (BF 2xx-TN-ST) with 3-pin plug-in connectors cable 1 m, 6 x 0,75 mm <sup>2</sup> (BF 2xx-TN-ST) with 6-pin plug-in connectors	
Response temperature thermal fuse	duct outside temperature +72°C duct inside temperature +72°C	

**Thermoelectric activation device BAT**

- If the thermal fuse Tf1 is interrupted (due to temperature outside the duct), it is necessary to replace the spring return actuator. Thermoelectric activation device BAT is integral part of the actuator.
- If the thermal fuse Tf2 is interrupted (due to temperature inside the duct), only the spare part ZBAT 72 (95/120/140) needs to be replaced (acc.to the activation temperature).
- When one of the thermal fuses responds, the supply voltage is interrupted permanently and irreversibly.
- The function (interruption of the supply voltage) can be checked by pressing the test button.
- Installation is carried out with the pre-assembled, self-tapping screws.



**BELIMO ZBAT 72**  
Black (BK) = 72°C (standard)



**BELIMO ZBAT 95**  
Grey (GY) = 95°C

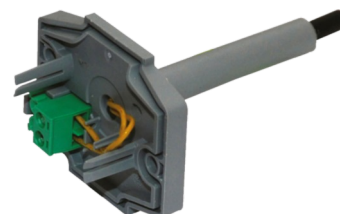

**BELIMO ZBAT 120**  
Orange (OG) = 120°C

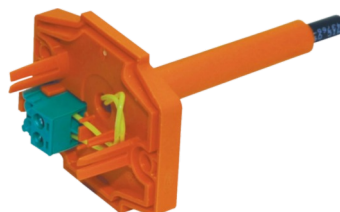

**BELIMO ZBAT 140**  
Red (RD) = 140°C

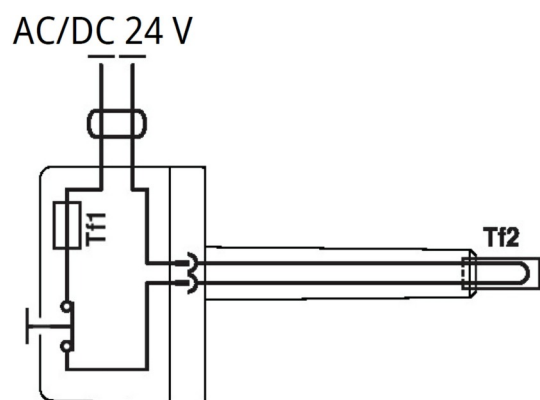
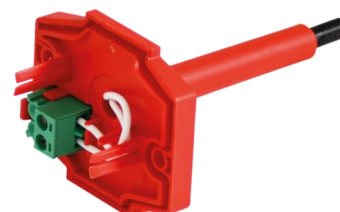

**Thermoelectric activation device BAT 72 (95/120/140)**

Power voltage	AC/DC 24 V 50/60Hz
Rated current	1 A
AC/DC throughput resistance	<1 Ω
Protection class	III
Degree of protection	IP 54
Probe length	65 mm
Ambient temperature	-30°C ... +50°C
Storage temperature	-40°C ... +50°C
Ambient humidity	Max. 95% RH, non-condensing
Connection supply	Cable 1 m, 2 x 0.5 mm <sup>2</sup> , Betaflam cable heatresistant up to 145°C
Response temperature thermal fuse	Duct inside temperature +72 (95/120/140)°C Duct outside temperature +72 (95/120/140)°C

**Design .41 and .51**

- Design .41 or .51 with actuator and smoke detector ORS 142 K. The voltage can be AC 230 V or 24 V DC. Design .41 with voltage AC 230 V is equipped with communication and supply device BKN 230-24-MOD and with actuator BF 24-TN (BFL 24-T, BFN 24-T).
- The smoke detector is activated when smoke spreads in air duct system. Deactivation of the smoke detector alarm status is provided by interruption of supply voltage for min. 2s.
- Signalisation of damper blade position "OPEN" and "CLOSE" is provided by two microswitches.

**Design .41 with actuator BF 24-TN (BFL, BFN 24-T), with smoke detector ORS 142 K and with supply device BKN 230-24-MOD (voltage AC 230 V)**

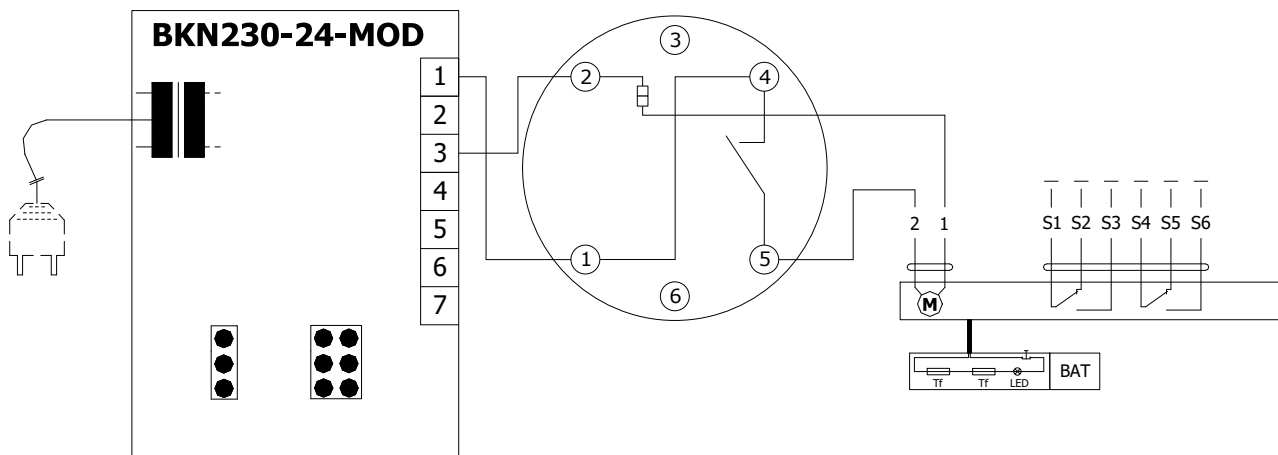

**Design .51 with actuator BF 24-TN (BFL, BFN 24-T), with smoke detector ORS 142 K (voltage 24 V DC)**

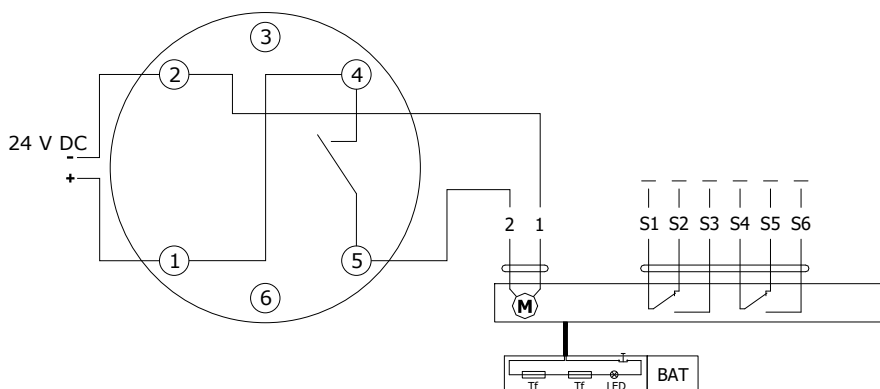

**Communication and supply device BKN 230-24-MOD**

Nominal voltage	AC 230 V 50/60Hz
Power consumption	3 W (operating position)
Dimensioning	14 VA (including actuator)
Protection Class	II
Degree of protection	IP 40
Ambient temperature	-20°C ... +50°C
Non-operating temperature	-40°C ... +80°C
Connection - net	cable 0,9 m with EURO plug type 26
- motor	6-pole connector, 3-pole connector
- terminal board	screw terminals for cable 2x1,5 mm <sup>2</sup>

## Design with the communication and supply device

### Design .63, 63S

- Design with the communication and supply device BKN 230-24-MOD and actuator BF 24-TN-ST (BFL 24-T-ST, BFN 24-T-ST) for communication with control systems using the Modbus RTU or BACnet MS / TP. Design 63. can be extended with an optical smoke detector ORS 142 K (design .63S).
- The wiring of the line is to be carried out in accordance with applicable RS485 regulations.
- Parameterization of the communication is done using DIL switches.
- BKN 230-24-MOD can be installed separately, without a connection to a master control system, in which case the connection bridge between the terminals 1 and 4 must be installed.
- If the test button on BAT is pressed or if the power supply (e.g. by a signal from ELECTRICAL FIRE SIGNALISATION ) is disconnected, the damper blade position will be "FAILURE".
- For design 63S the smoke detector is activated when smoke spreads in air duct system. Deactivation of the smoke detector alarm status is provided by interruption of supply voltage for min. 2s.

### Design with communication and supply device BKN 230-24-MOD, with actuator BF 24-TN-ST (BFL 24-T-ST, BFN 24-T-ST) and smoke detector ORS 142 K

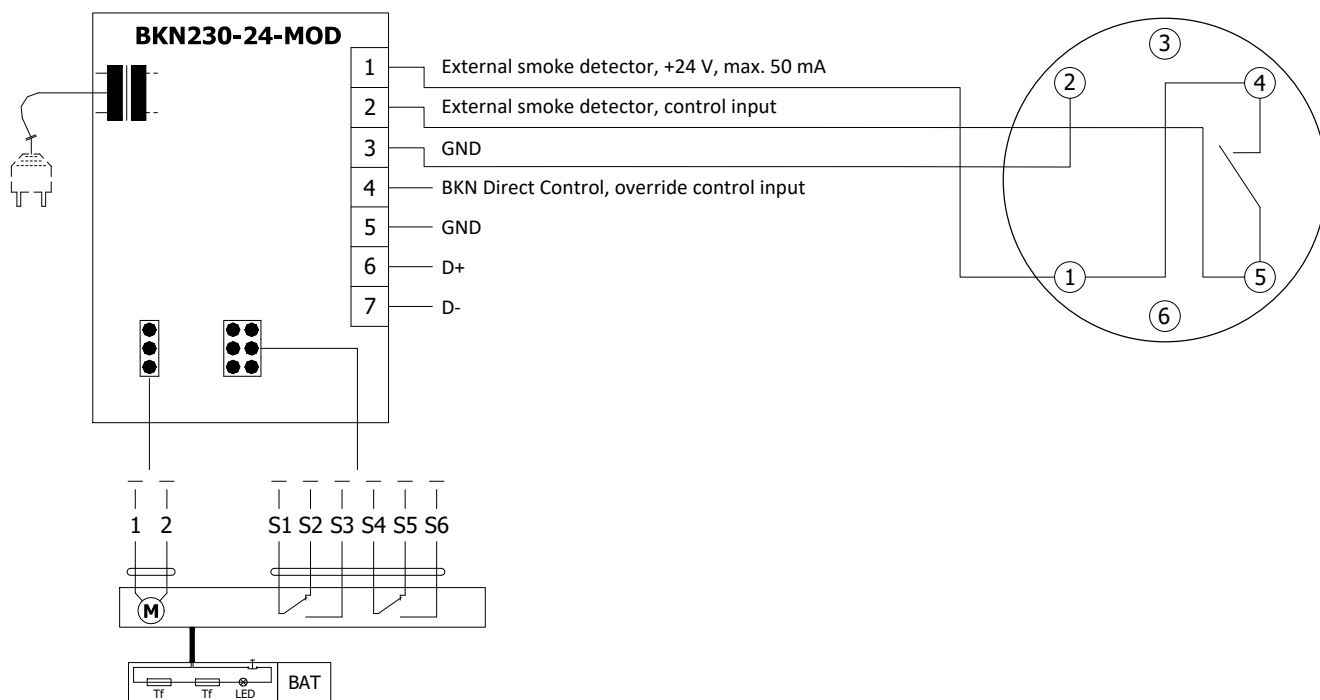

#### Communication and supply device BKN 230-24-MOD

Nominal voltage	AC 230 V 50/60Hz
Power consumption	3 W (operating position)
Dimensioning	14 VA (including actuator)
Protection Class	II
Degree of protection	IP 40
Ambient temperature	-20°C ... +50°C
Non-operating temperature	-40°C ... +80°C
Connection - net	cable 0,9 m with EURO plug type 26
- motor	6-pole connector, 3-pole connector
- terminal board	screw terminals for cable 2x1,5 mm <sup>2</sup>

**Optical smoke detector ORS 142 K with the socket 143A**

- The smoke detector ORS 142 K is used for early smoke detection in rooms or inside the ventilation system.
- The sensor operates on the light scatter principle. Inside the scanning chamber is a light source and a light sensor, in the normal state the light from the source does not fall on the sensor. Only when smoke enters the scanning chamber the light is scattered and falls on the sensor.
- The smoke detector can be connected directly to the actuator (design .41 and .51) which, in case of smoke detection, passes to the safety position, or to the BKN communication and supply device (design .63).
- By early detection of smoke, it can be effectively prevented from spreading of smoke through the ventilation system. In addition to smoke detection, the sensor can distinguish and signal slight and heavy contamination, e.g. the presence of large amounts of dust.
- The ORS 142 K smoke detector has an alarm memory, i.e. if the alarm is triggered, the safety relay opens and stays in this state even if the smoke disappears from the scanning chamber. The sensor remains in the alarm state until the power supply is briefly reset.
- On the pin 3, an external device can be connected via RS-Bus communication to report the status of the sensor.
- Pin 6 has no connection to the detector and is designed as a load-bearing structure in the base.

**ORS 142 K**



**Socket 143A**



RS-Bus communication

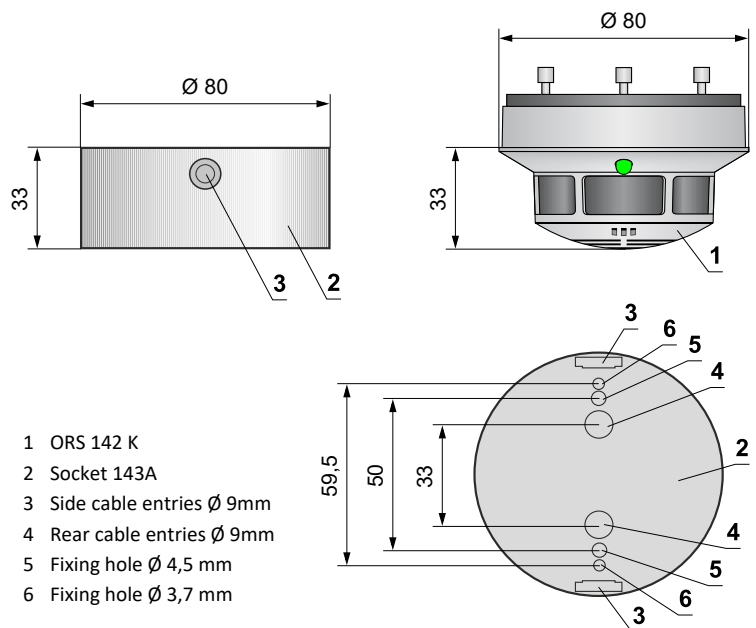
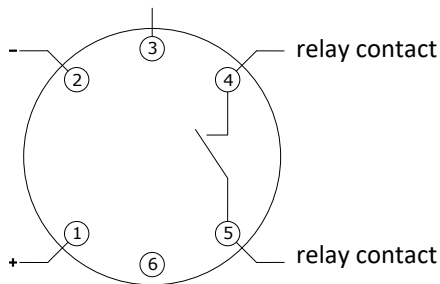

Relay contact		LED	
In operation		Green	Shines
Slight contamination		Green / Yellow	Flashes
Heavy contamination		Green / Yellow	Flashes
Fault		Yellow	Shines
Alarm		Red	Shines
Power Off		Off	-

- 1 ORS 142 K
- 2 Socket 143A
- 3 Side cable entries Ø 9mm
- 4 Rear cable entries Ø 9mm
- 5 Fixing hole Ø 4,5 mm
- 6 Fixing hole Ø 3,7 mm

**Optical smoke detector ORS 142 K with the socket 143A**

Operating voltage	18 ... 28 V DC
Residual ripple	≤ 200 mV
Power Consumption Socket (without actuator)	max. 22 mA
Degree of protection	IP 42
Ambient temperature	-20°C ... +75°C
Additional temperature sensor	+70°C
Connection - net	Cabel 1m, connected to terminals 1, 2 and 4
- motor	Actuator connected on the terminals 2 and 5
- communication and supply device BKN	Cabel 1m, connected to terminals 1, 2, 4 and 5

### III. DIMENSIONS

**SPIRO design with manual control**

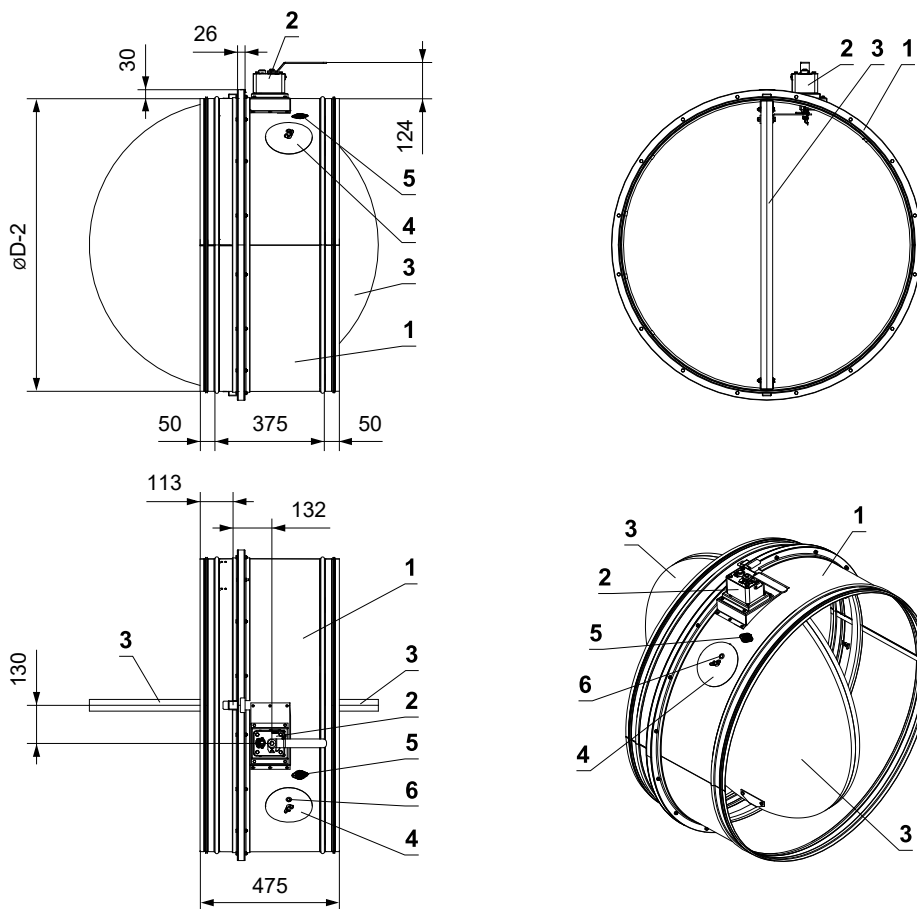

- 1 Damper casing
- 2 Manual control
- 3 Damper blade
- 4 Inspection opening cover
- 5 Sensor sticker
- 6 Hole for camera

**Design SPIRO with spring return actuator**

■ The actuator can be rotated 90°

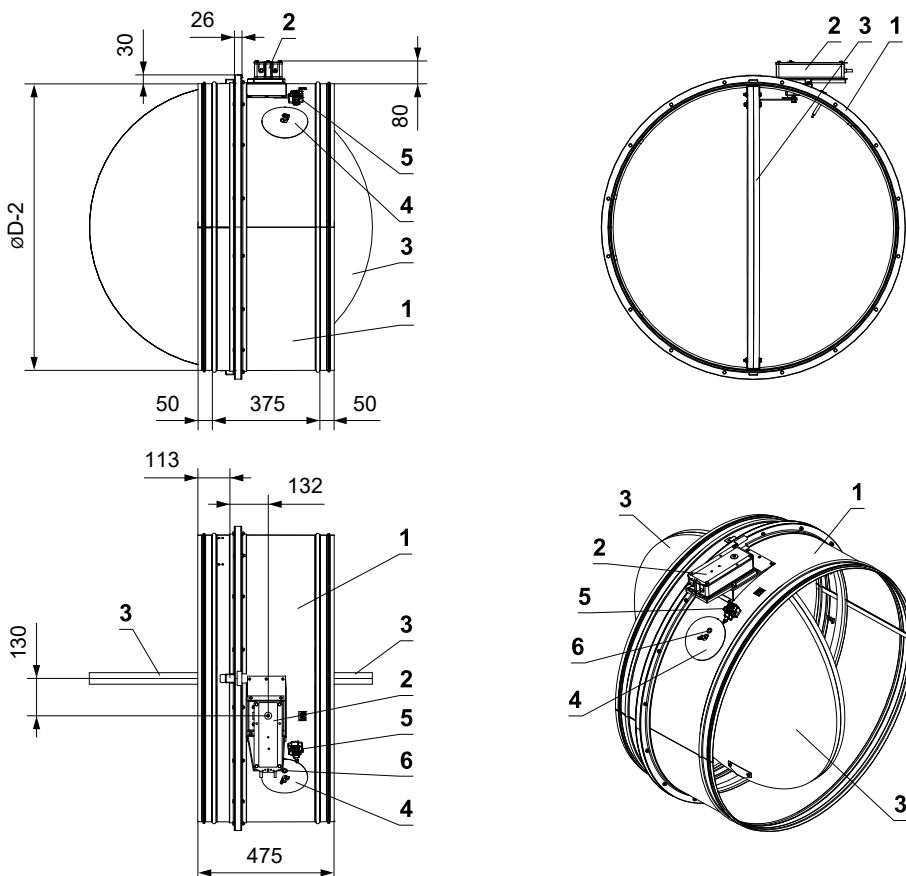

- 1 Damper casing
- 2 Spring return actuator
- 3 Damper blade
- 4 Inspection opening cover
- 5 Thermoelectric activation device BAT
- 6 Hole for camera

FLANGE design with manual control

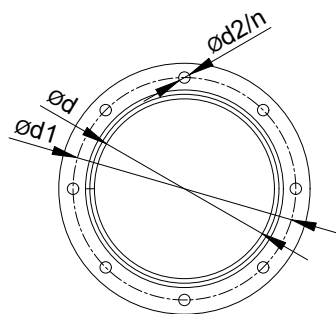

$\varnothing d$ [mm]	$\varnothing d1$ [mm]	$\varnothing d2$ [mm]	n number of holes in the flange
900	960	15	24
1000	1070	19	24

- 1 Damper casing
- 2 Manual control
- 3 Damper blade
- 4 Inspection opening cover
- 5 Sensor sticker
- 6 Hole for camera

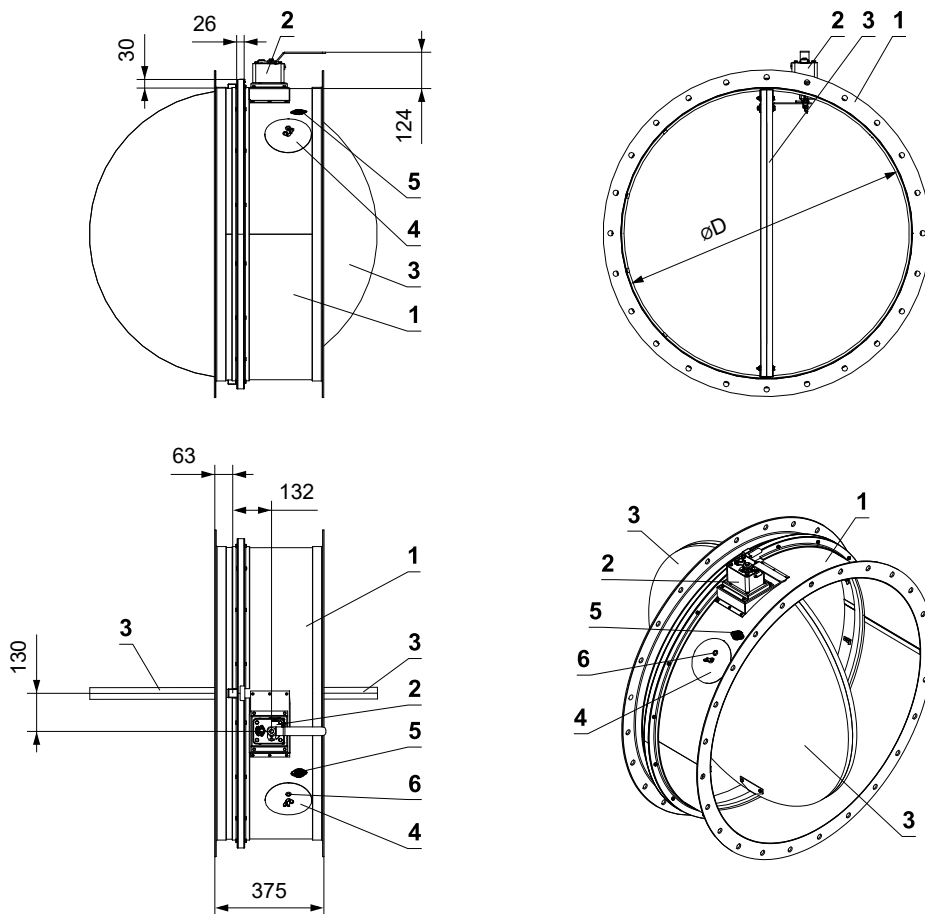

Design FLANGE with spring return actuator

■ The actuator cannot be rotated

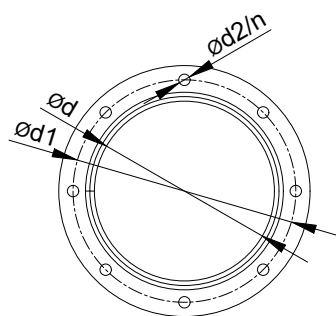

$\varnothing d$ [mm]	$\varnothing d1$ [mm]	$\varnothing d2$ [mm]	n number of holes in the flange
900	960	15	24
1000	1070	19	24

- 1 Damper casing
- 2 Spring return actuator
- 3 Damper blade
- 4 Inspection opening cover
- 5 Thermoelectric activation device BAT
- 6 Hole for camera

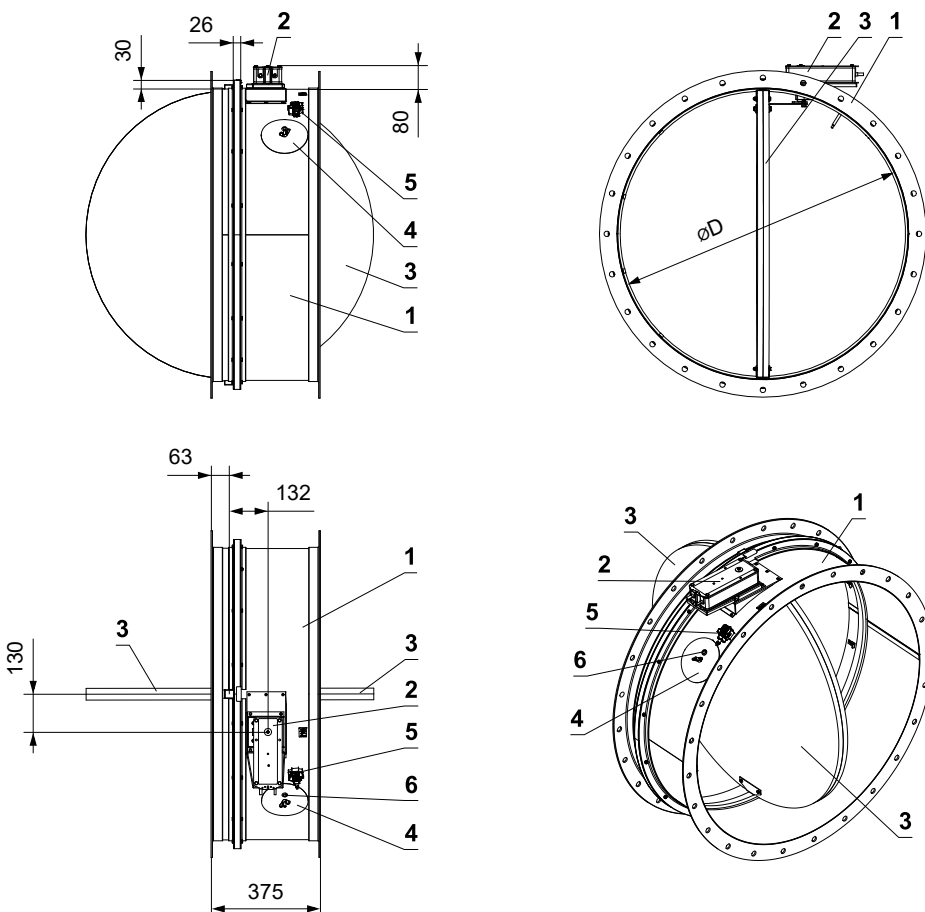

Damper blade overlaps

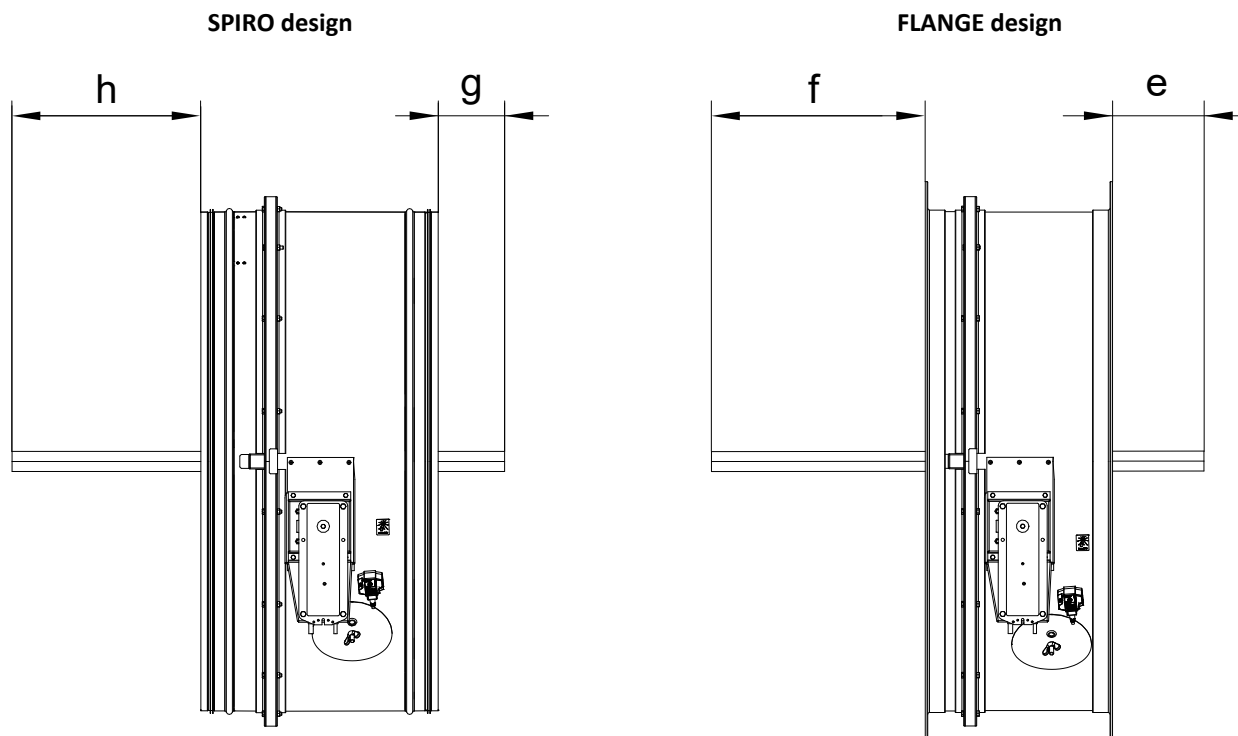

Values "h" and "g" resp. "f" and "e" has to be respected when projecting following air-conditioning duct.

Technical parameters

SPIRO design

Nominal size ØD [mm]	Damper blade overlaps		Weight		Free area S <sub>f</sub> [m <sup>2</sup> ]	Spring return actuator	Manual control
	h [mm]	g [mm]	Man. control [kg]	Spring return actuator [kg] *			
900	326,5	84,5	47,8	50,2	0,5727	BF	M5
1000	376,5	134,5	55,8	58,2	0,7147		

\* For designs with BKN a weight of 0.5 kg must be added.

FLANGE design

Nominal size ØD [mm]	Damper blade overlaps		Weight		Free area S <sub>f</sub> [m <sup>2</sup> ]	Spring return actuator	Manual control
	f [mm]	e [mm]	Man. control [kg]	Spring return actuator [Kg] *			
900	376,5	134,5	51	53	0,5727	BF	M5
1000	426,5	184,5	59	61	0,7147		

\* For designs with BKN a weight of 0.5 kg must be added.

## IV. INSTALLATION

### Placement and installation

- The fire dampers are suitable for installation in arbitrary position in vertical and horizontal passages of fire separating constructions. The damper installation procedures must be done so that all load transfer from the fire separating constructions to the damper is absolutely excluded. Following air-conditioning duct must be suspended or supported so that all load transfer from the following duct to the fire damper is absolutely excluded. The gap between the installed damper and the fire separating construction must be perfectly filled with approved material.
- The damper must be installed so that the damper blade (in closed position) is situated in the fire separating construction - marked by the label BUILT-IN EDGE on the damper casing. If such solution is not possible, the duct between the fire separating construction and the damper blade must be protected according to the certified installation method → see pages 19 to 45
- During the installation and plastering process, the actuating mechanism must be protected (covered) against damage and pollution. The damper casing should not be deformed during bricking in. Once the damper is built in, the damper blade should not grind against the damper casing during opening or closing.
- The distance between the fire damper and the construction (wall, ceiling) must be 75 mm at the minimum, according to EN 1366-2. If two or more dampers are to be installed in one fire separating construction, the distance between adjacent dampers must be 200 mm at the minimum, according to EN 1366-2.

#### Minimum distance between the fire dampers and the construction

- minimum distance 200 mm between dampers, according to EN 1366-2
- minimum distance 75 mm between damper and construction (wall/ceiling), according to EN 1366-2
- recommended minimum distance 150 mm necessary for access to the actuator
- recommended minimum distance 250 mm necessary for access to the manual control

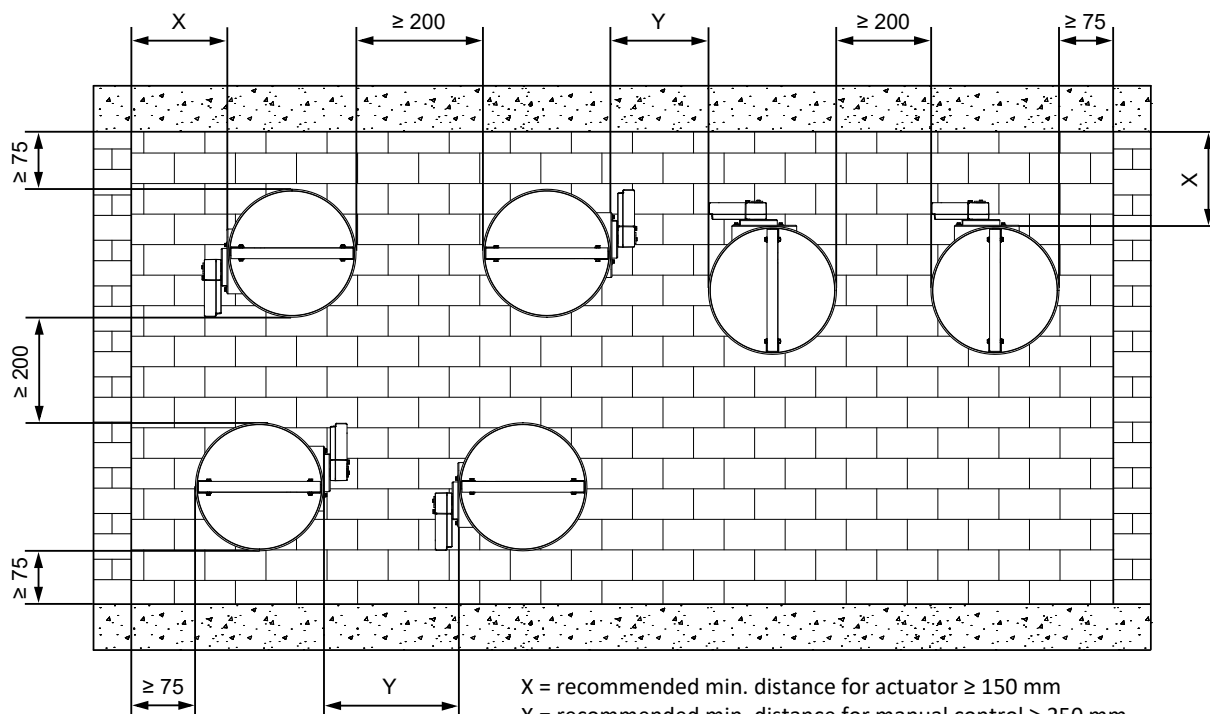

X = recommended min. distance for actuator  $\geq 150$  mm  
 X = recommended min. distance for manual control  $\geq 250$  mm  
 Y = min. distance for actuator  $\geq 200$  mm acc. to EN 1366-2  
 Y = recommended min. distance for manual control  $\geq 250$  mm

Built in edge

SPIRO design

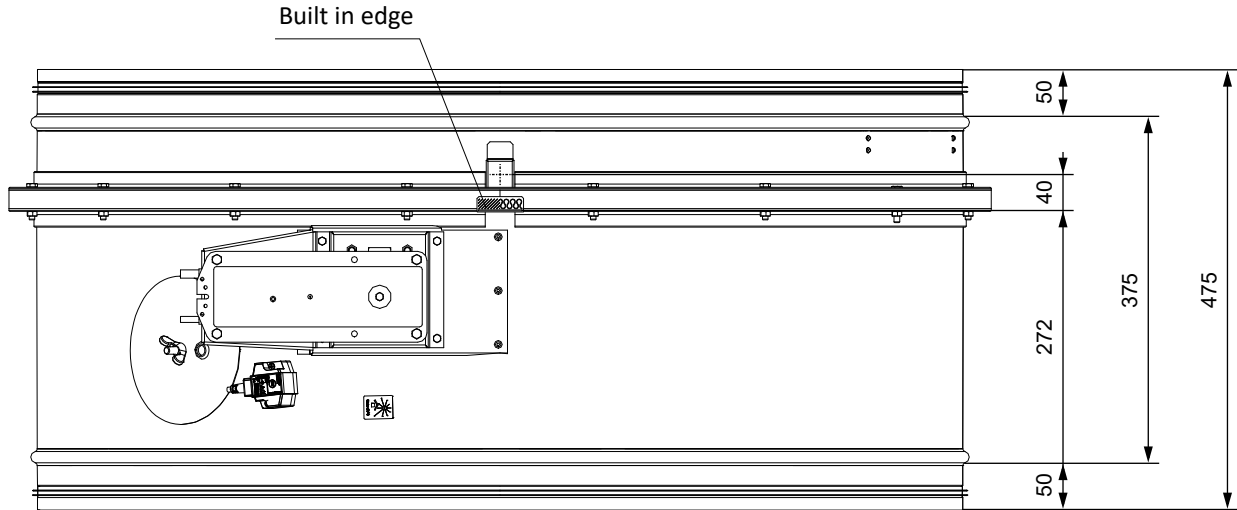

FLANGE design

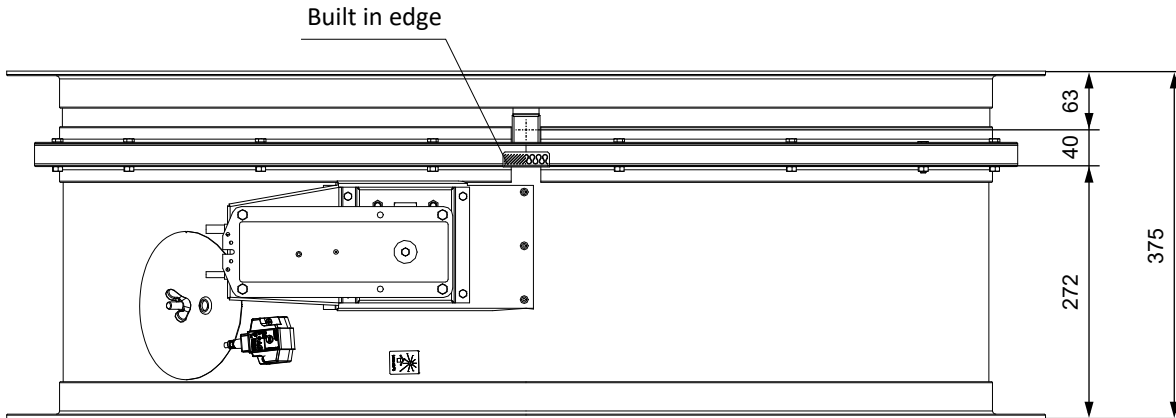

Dimensions of an installation opening  
Mortar or gypsum / Ablative Coated Batt

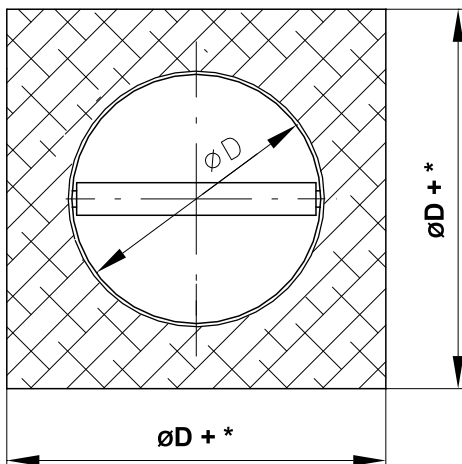

Dimensions of an installation opening  
Mortar or gypsum

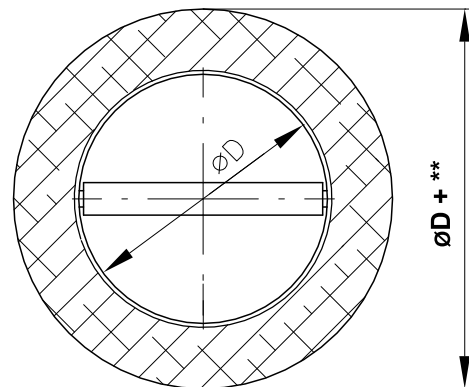

\* Mortar or gypsum

- min.  $\varnothing D + 80$
- max.  $\varnothing D + 300$

\* Ablative Coated Batt

- min.  $\varnothing D + 80$
- max.  $\varnothing D + 800$

\* Stuffing box with fire protection boards

- min.  $\varnothing D + 80$
- max.  $\varnothing D + 220$

\*\* Mortar or gypsum

- min.  $\varnothing D + 80$
- max.  $\varnothing D + 300$

## Statement of installations

Installation	wall/ceiling min. thickness [mm]	Method of installation	Fire resistance	Page
In solid wall construction	100	Mortar or gypsum	EI 90 (v <sub>e</sub> i↔o) S EI 120 (v <sub>e</sub> i↔o) S*	19
		2 dampers in one opening - mortar or gypsum		20
		Ablative Coated Batt	EI 90 (v <sub>e</sub> i↔o) S	21
		Mineral wool with fire-resistant coating and fire-resistant boards		22
		Installation next to the wall/ceiling - mortar or gypsum + mineral wool		23
		Installation next to the wall/ceiling - mortar or gypsum	EI 90 (v <sub>e</sub> i↔o) S	24
Outside solid wall construction	100	ISOVER Ultimate Protect - mortar or gypsum		25
		ISOVER Ultimate Protect - Ablative Coated Batt	EI 45 (v <sub>e</sub> i↔o) S	26
		Mineral wool ROCKWOOL - Mineral wool with fire-resistant coating and fire-resistant board	EI 90 (v <sub>e</sub> i↔o) S	27
In gypsum wall construction	100	Mortar or gypsum	EI 90 (v <sub>e</sub> i↔o) S EI 120 (v <sub>e</sub> i↔o) S*	28
		2 dampers in one opening - mortar or gypsum		29
		Ablative Coated Batt	EI 90 (v <sub>e</sub> i↔o) S	30
		Mineral wool with fire-resistant coating and fire-resistant boards		31
		Installation next to the wall/ceiling - mortar or gypsum + mineral wool		32
		Installation next to the wall/ceiling - mortar or gypsum	EI 90 (v <sub>e</sub> i↔o) S	33
Outside gypsum wall construction	100	ISOVER Ultimate Protect - mortar or gypsum		34
		ISOVER Ultimate Protect - Ablative Coated Batt	EI 45 (v <sub>e</sub> i↔o) S	35
		Mineral wool ROCKWOOL - Mineral wool with fire-resistant coating and fire-resistant board	EI 90 (v <sub>e</sub> i↔o) S	36
In shaft wall Rigips	110	Mortar or gypsum	EI 90 (v <sub>e</sub> i↔o) S	37-38
In solid ceiling construction	150	Mortar or gypsum	EI 90 (h <sub>o</sub> i↔o) S EI 120 (h <sub>o</sub> i↔o) S*	39
		2 dampers in one opening - mortar or gypsum		40
		Ablative Coated Batt	EI 90 (h <sub>o</sub> i↔o) S	41
		Mineral wool with fire-resistant coating and fire-resistant boards		42
Outside solid ceiling construction	150	Mineral wool ROCKWOOL - mortar or gypsum		43
		Concreting	EI 90 (h <sub>o</sub> i↔o) S	44

\* Requirement to EI 120 (v<sub>e</sub> h<sub>o</sub> i↔o) S must be specified in the order alone.  
Without specification is supplied standard damper EI 90 (v<sub>e</sub> h<sub>o</sub> i↔o) S.

**Installation in solid wall construction**

**In solid wall construction - mortar or gypsum**

- For connection of following duct → see page 47

**EI 90 (v<sub>e</sub> i↔o) S**

**EI 120 (v<sub>e</sub> i↔o) S\***

\* Requirement to **EI 120 (v<sub>e</sub> i↔o) S** must be specified in the order alone. Without specification is supplied standard damper **EI 90 (v<sub>e</sub> i↔o) S**.

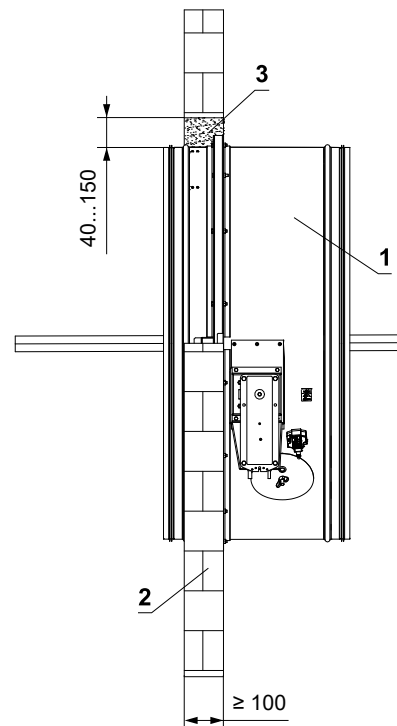
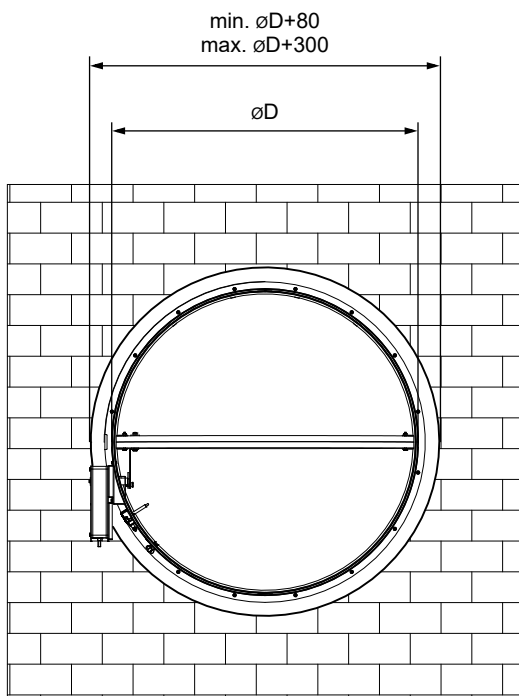
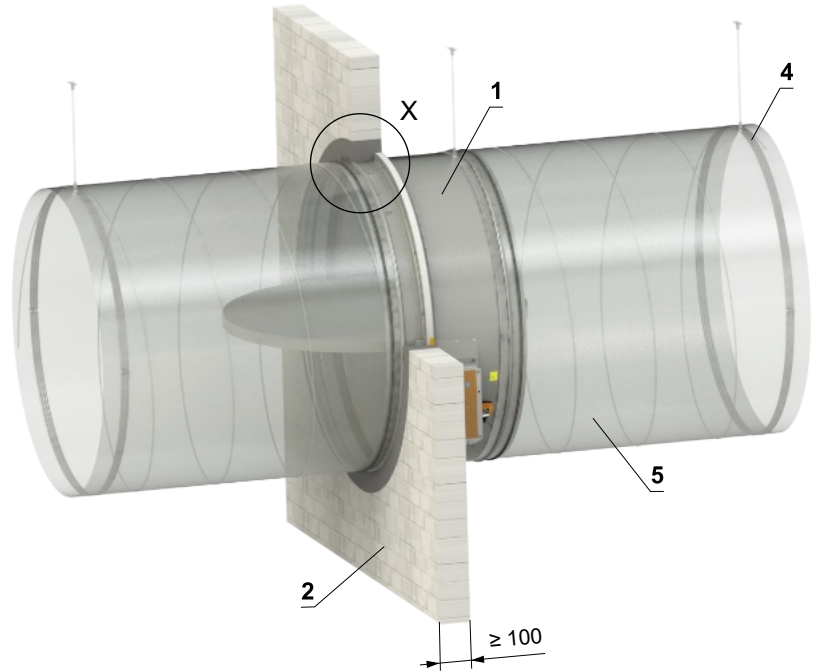
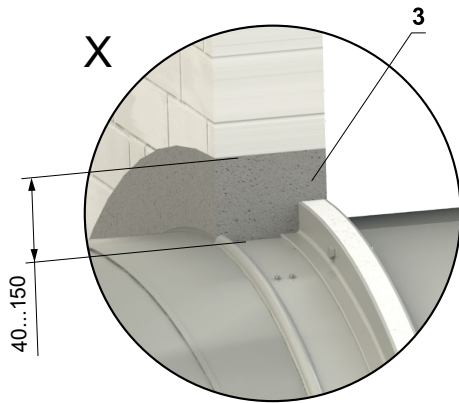

- 1 FDMA-PM
- 2 Solid wall construction
- 3 Mortar or gypsum
- 4 Clamp with threaded rod → see pages 46 to 47
- 5 Duct

In solid wall construction - 2 dampers in one opening - mortar or gypsum

EI 90 (v<sub>e</sub> i↔o) S

- For connection of following duct → see page 47
- The gap between the damper and construction is filled with mortar or gypsum
- It is possible to install up to 4 dampers symmetrically in one opening

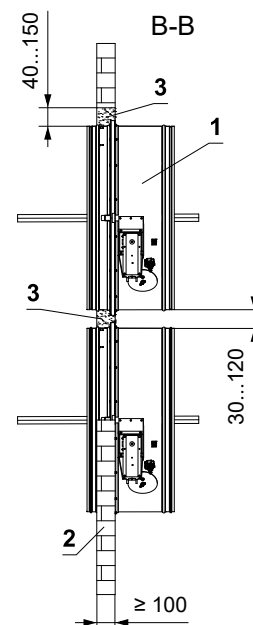
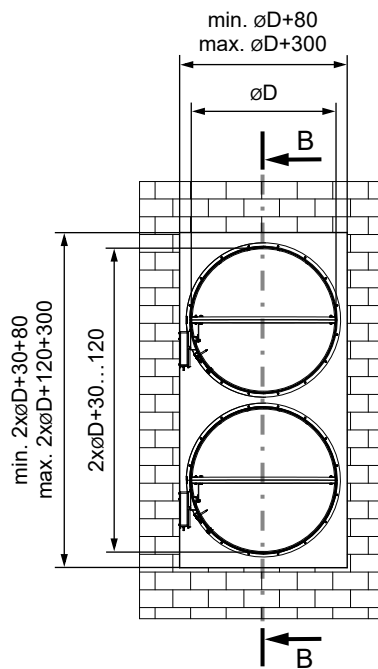
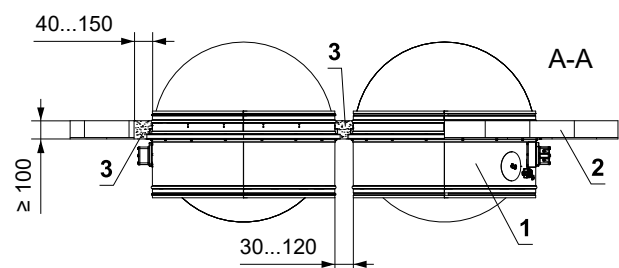
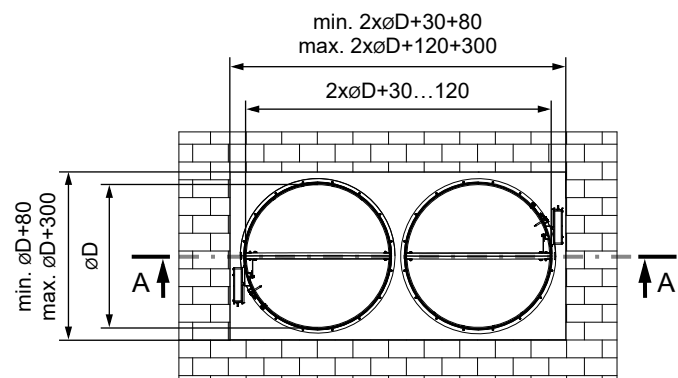
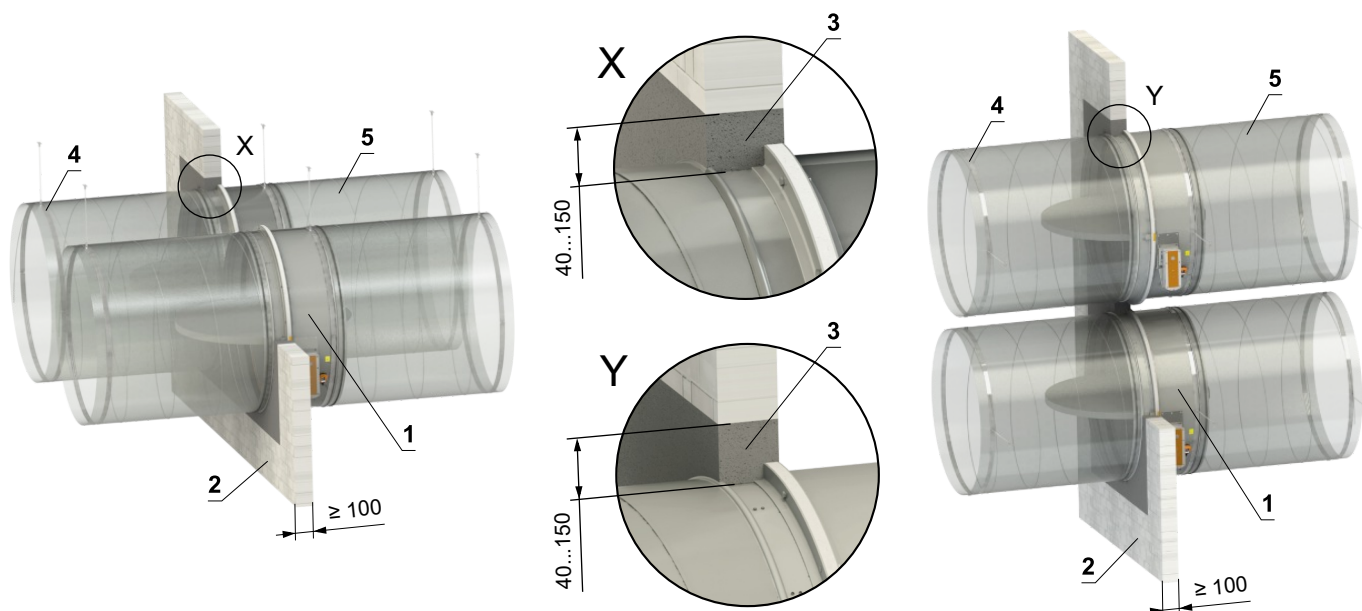

- 1 FDMA-PM
- 2 Solid wall construction
- 3 Mortar or gypsum
- 4 Clamp with threaded rod → see pages 46 to 47
- 5 Duct

In solid wall construction - Ablative Coated Batt

EI 90 (v<sub>e</sub> i↔o) S

■ For connection of following duct → see page 47

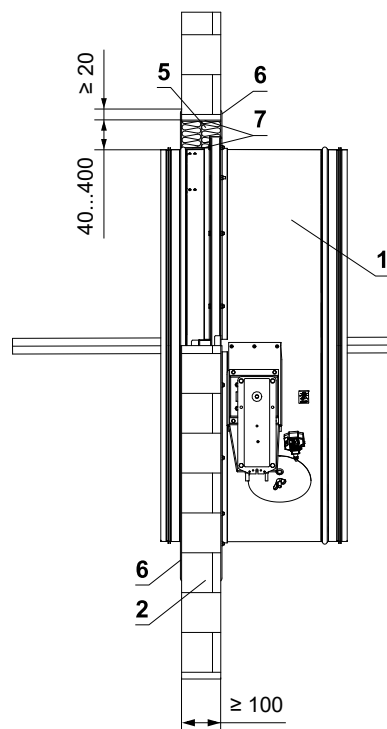
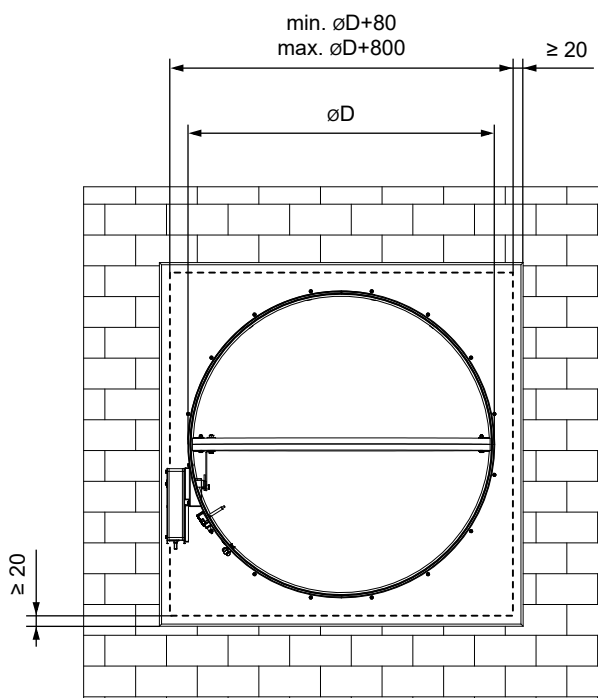
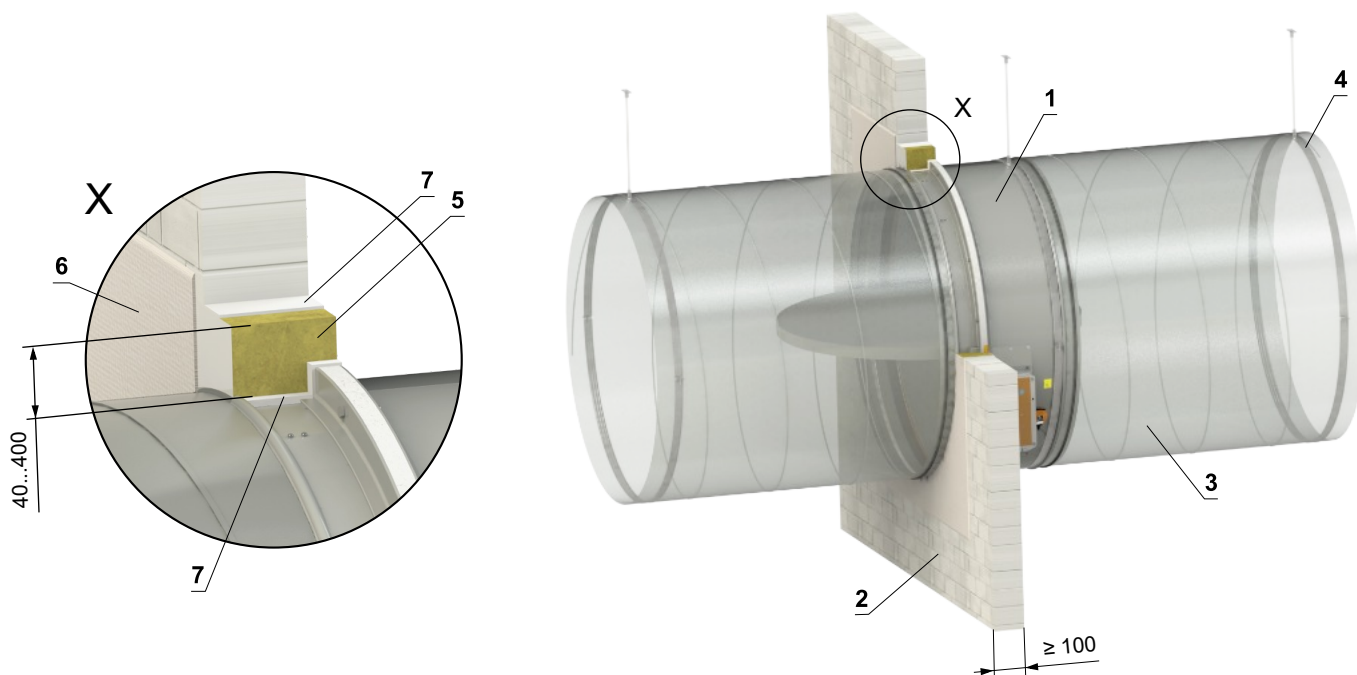

- 1 FDMA-PM
  - 2 Solid wall construction
  - 3 Duct
  - 4 Clamp with threaded rod → see pages 46 to 47
- Ablative Coated Batt System HILTI\*
- 5 Mineral wool board - min. density 140 kg/m<sup>3</sup> (HILTI CFS-CT B 1S 140/50...)
  - 6 Fire stop coating - th. 1 mm (HILTI CFS-CT...) - coating is overcoated on the support construction and on the damper casing/duct
  - 7 Fire-resistant mastic - (HILTI CFS-S ACR...) fill the gap from both sides of the fire separation construction and around the perimeter of penetration and damper casing.

\* HILTI system can be replaced by a similar system with the same or higher thickness, density, fire reaction class, tested according to EN 1366-3.

In solid wall construction - mineral wool with fire-resistant coating and fire-resistant boards

EI 90 (v<sub>e</sub> i↔o) S

■ For connection of following duct → see page 47

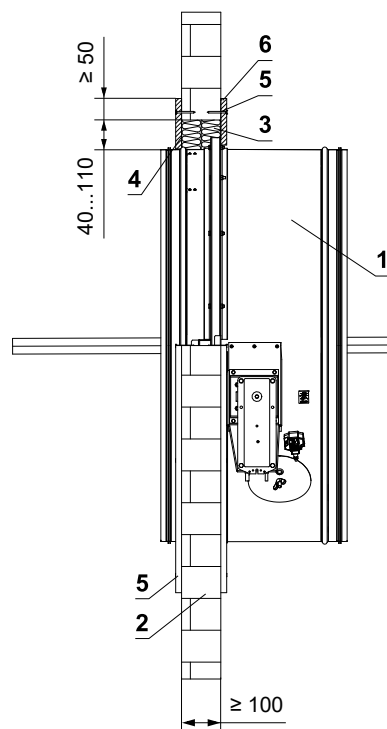
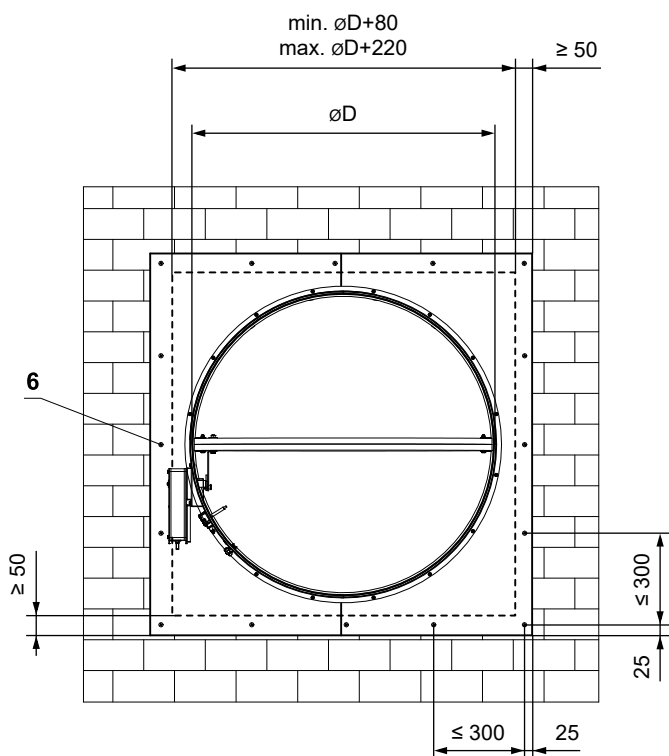
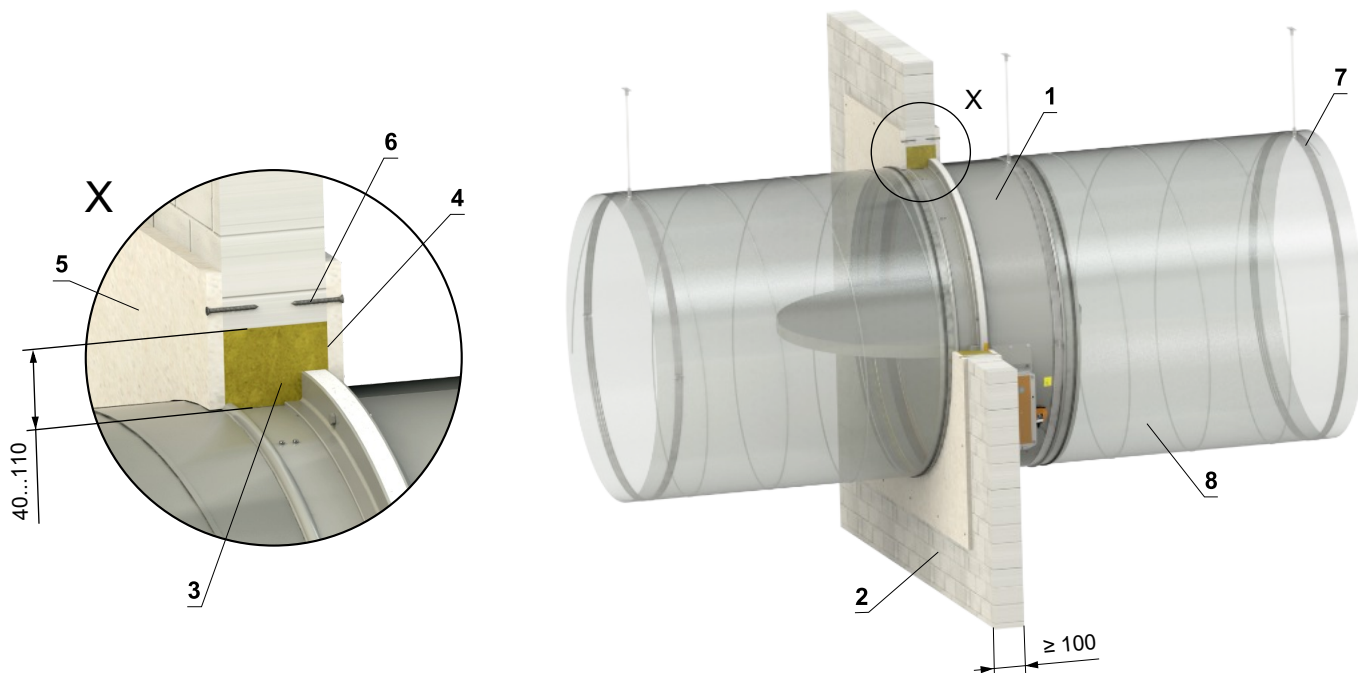

- 1 FDMA-PM
- 2 Solid wall construction
- 3 Mineral wool board - min. density 140 kg/m<sup>3</sup> (e.g. PROMAPYR-T150, ROCKWOOL HARDROCK / STEPROCK HD)
- 4 Fire-resistant coating - th. 1 mm (e.g. PROMASTOP-I)
- 5 Fire-resistant board - min. th. 15 mm, min. density 870 kg/m<sup>3</sup> (e.g. PROMATECT-H)
- 6 Screw 4x50 mm - screws must be fixed in the wall construction, use steel anchors if necessary
- 7 Clamp with threaded rod → see pages 46 to 47
- 8 Duct

**In solid wall construction - installation next to the wall/ceiling - mortar or gypsum + mineral wool**

EI 90 (v<sub>e</sub> i↔o) S

- For connection of following duct → see page 47
- Conditions of this installation are also valid for the installation in Solid ceiling construction.
- Penetration is filled with mortar or gypsum + mineral wool (shape, according to the location of the damper). Fix the mineral wool with glue (e.g. Promat K84 or equivalent) to the construction and damper casing

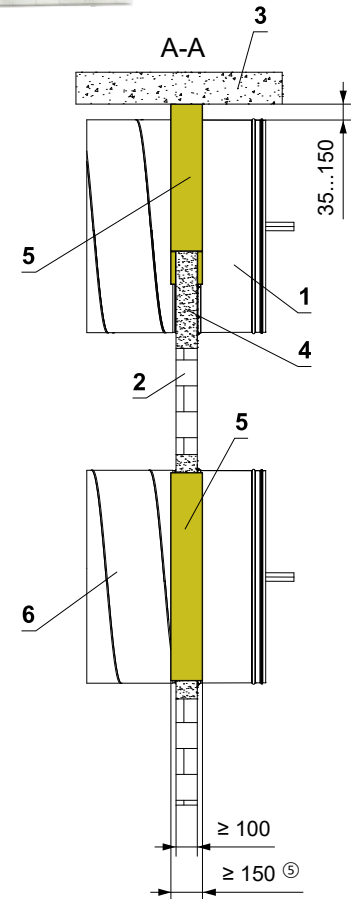
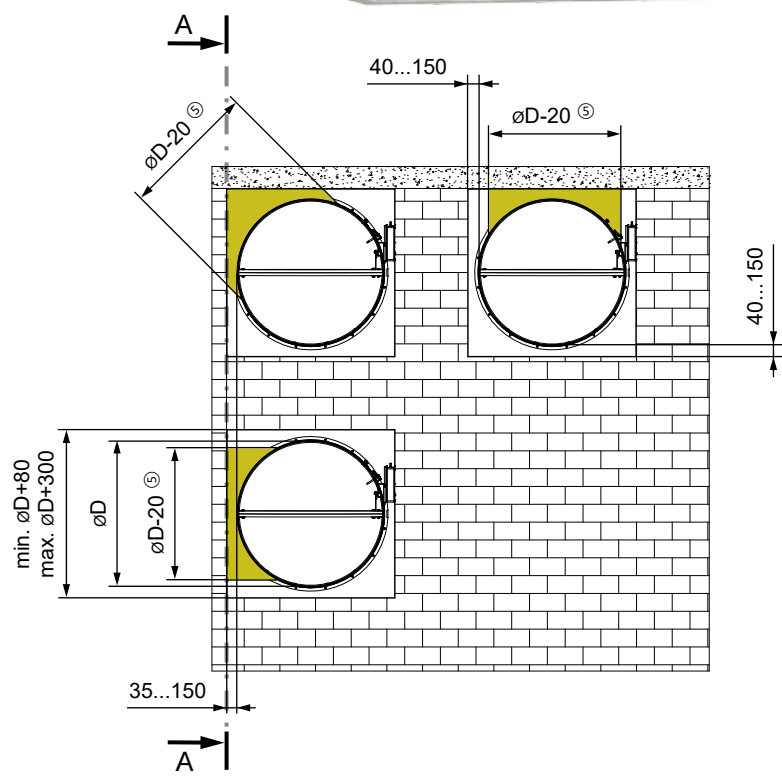
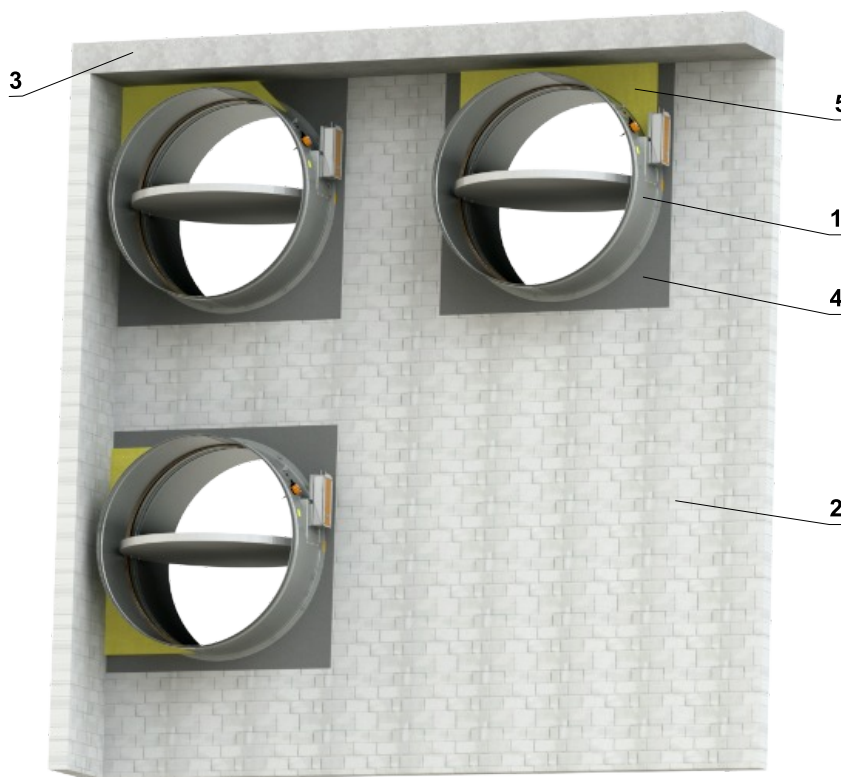

- 1 FDMA-PM
- 2 Solid wall construction
- 3 Solid ceiling construction
- 4 Mortar or gypsum
- 5 Mineral wool board - min. density 140 kg/m<sup>3</sup> (e.g. PROMAPYR-T150, ROCKWOOL HARDROCK / STEPROCK HD)
- 6 Duct

In solid wall construction - installation next to the wall/ceiling - mortar or gypsum

EI 90 (v<sub>e</sub> i↔o) S

- For connection of following duct → see page 47
- Conditions of this installation are also valid for the installation in Solid ceiling construction.

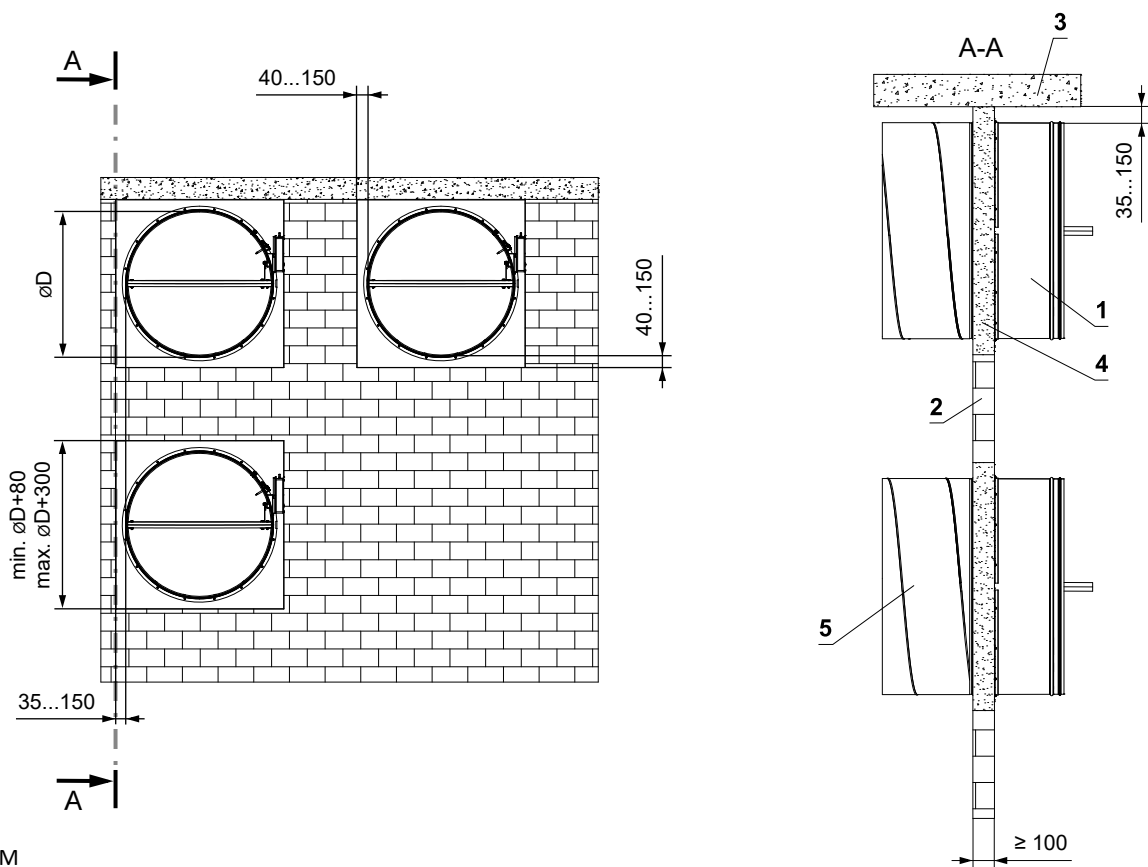
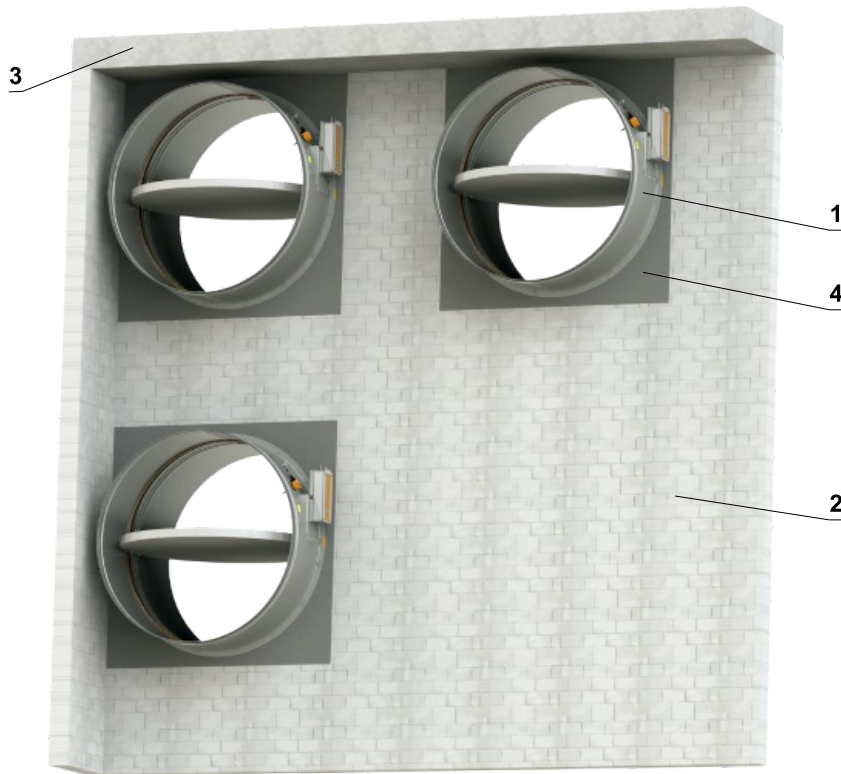

- 1 FDMA-PM
- 2 Solid wall construction
- 3 Solid ceiling construction
- 4 Mortar or gypsum
- 5 Duct

## Installation outside solid wall construction

### Outside solid wall construction - ISOVER Ultimate Protect - mortar or gypsum

EI 45 (v<sub>e</sub> i↔o) S

- For connection of following duct → see page 47
- Minimum and maximum distance between the wall and fire damper is unlimited
- When installing the insulation, follow the ISOVER manufacturer's instructions
- The damper and the duct must be suspended separately
- The duct must be suspended on both sides of damper acc. to national rules
- Duct between fire damper and fire separating construction must be suspended by using threaded rods and mounting profiles, or another mounting system acc. to national standards
- Load of the suspension system depends on weight of the fire damper and duct system → see page 46
- Max. distance between two suspension systems is 1500 mm
- Following air-conditioning duct must be suspended or supported so that all load transfer from the following duct to the fire damper is absolutely excluded. Adjacent duct must be suspended or supported, as required by the duct suppliers
- If the threaded rod is located inside the duct insulation, distance between threaded rod and duct is max 30 mm
- If the threaded rod is located outside the duct isolation, distance between threaded rod and isolation is max. 40 mm

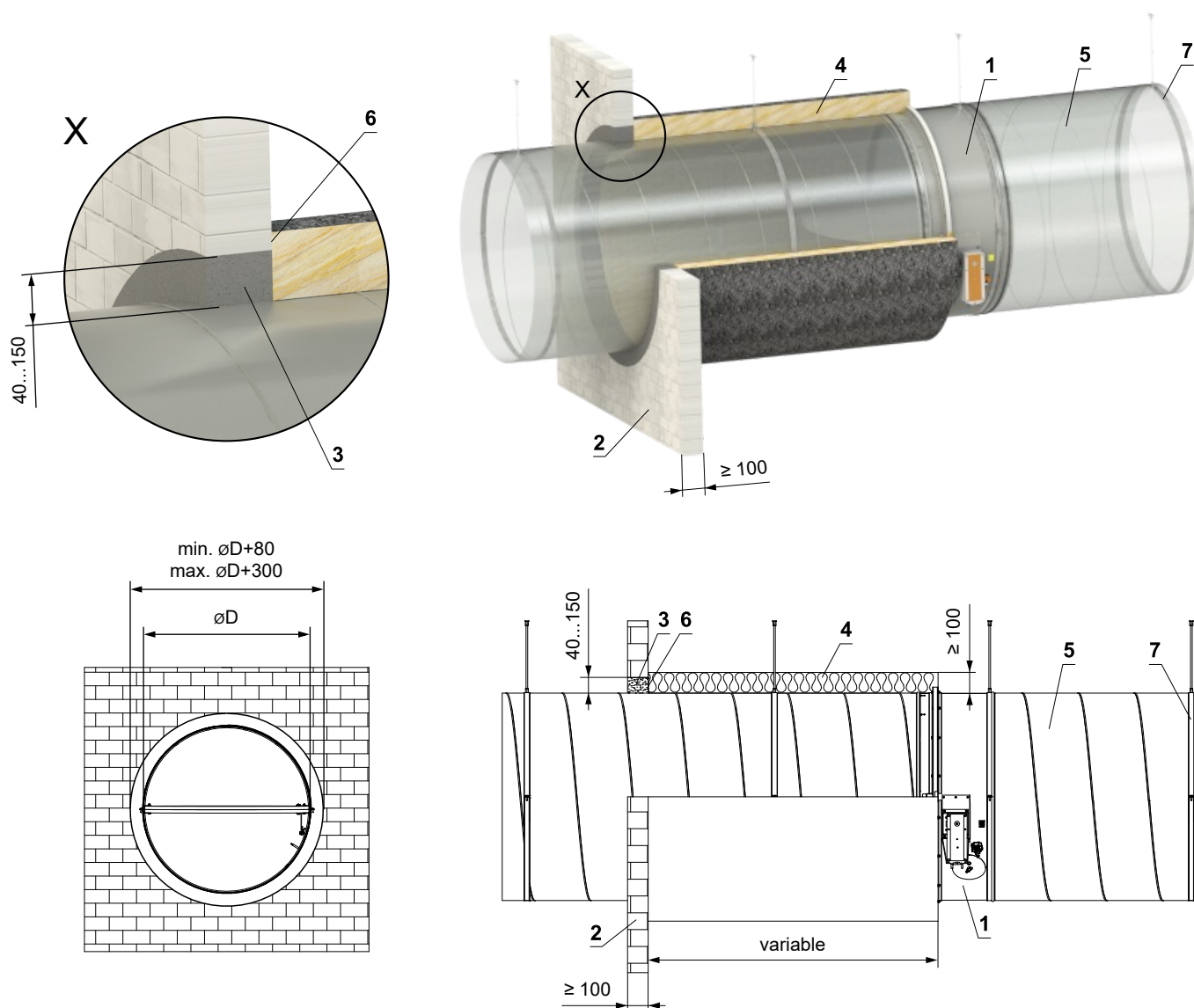

- 1 FDMA-PM
- 2 Solid wall construction
- 3 Mortar or gypsum
- 4 Insulation board made of mineral wool, with a surface treatment of aluminum foil, min. density 66 kg/m<sup>3</sup> (System ISOVER Ultimate Protect Wired Mat 4.0 Alu1)
- 5 Standard air duct, made of galvanized sheet metal min. thickness 0,8 mm
- 6 ISOVER Protect BSK glue - apply on the insulation and fix it to the fire separation construction
- 7 Clamp with threaded rod → see pages 46 to 47

Outside solid wall construction - ISOVER Ultimate Protect - Ablative Coated Batt

EI 45 (v<sub>e</sub> i↔o) S

- For connection of following duct → see page 47
- Minimum and maximum distance between the wall and fire damper is unlimited
- When installing the insulation, follow the ISOVER manufacturer's instructions
- The damper and the duct must be suspended separately
- The duct must be suspended on both sides of damper acc. to national rules
- Duct between fire damper and fire separating construction must be suspended by using threaded rods and mounting profiles, or another mounting system acc. to national standards
- Load of the suspension system depends on weight of the fire damper and duct system → see page 46
- Max. distance between two suspension systems is 1500 mm
- Duct at the point of penetration must be fixed to the fire separation structure
- Following air-conditioning duct must be suspended or supported so that all load transfer from the following duct to the fire damper is absolutely excluded. Adjacent duct must be suspended or supported, as required by the duct suppliers
- If the threaded rod is located inside the duct insulation, distance between threaded rod and duct is max 30 mm
- If the threaded rod is located outside the duct isolation, distance between threaded rod and isolation is max. 40 mm

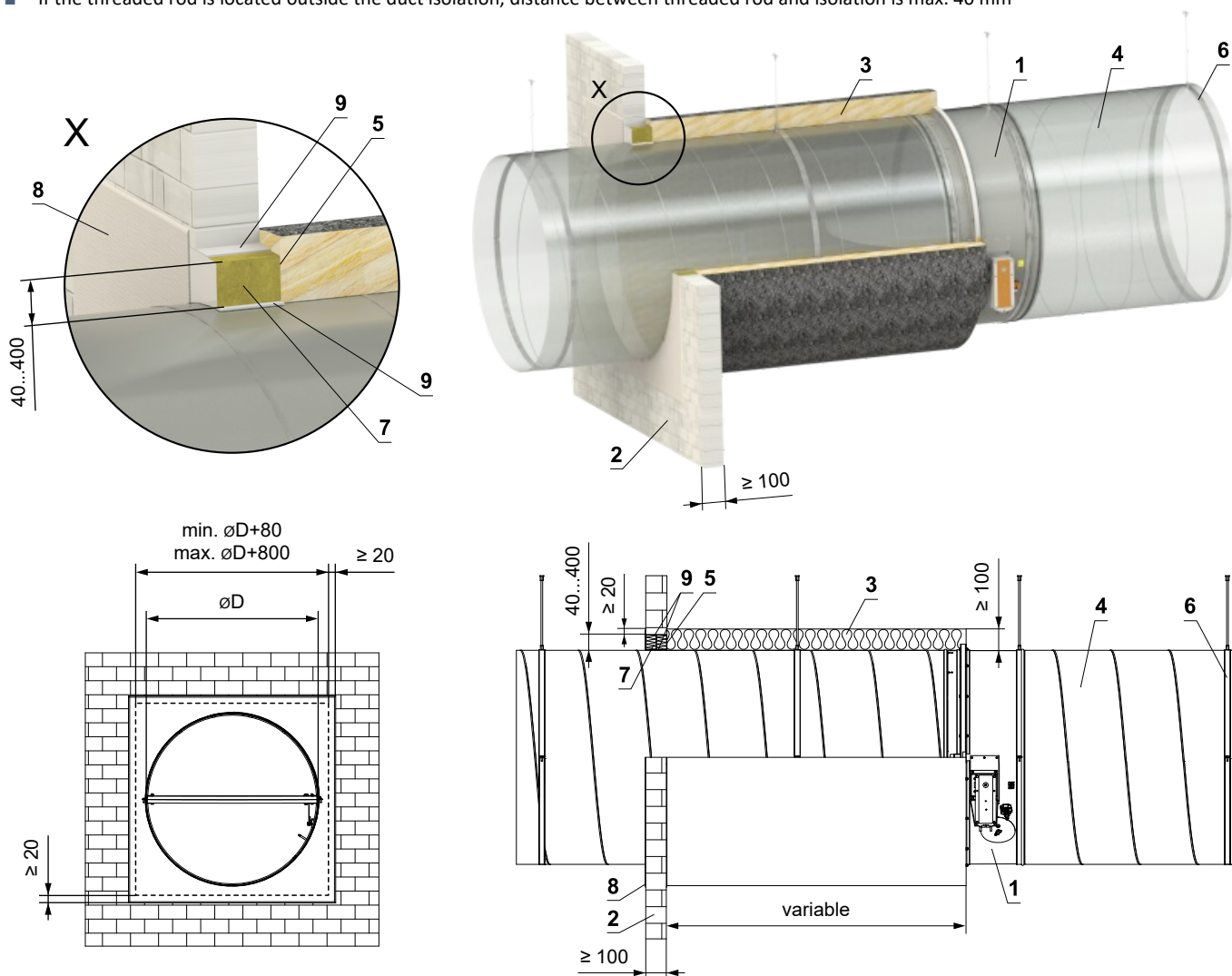

\* HILTI system can be replaced by a similar system with the same or higher thickness, density, fire reaction class, tested according to EN 1366-3.

- 1 FDMA-PM
  - 2 Solid wall construction
  - 3 Insulation board made of mineral wool, with a surface treatment of aluminum foil, min. density 66 kg/m<sup>3</sup> (System ISOVER Ultimate Protect Wired Mat 4.0 Alu1)
  - 4 Standard air duct, made of galvanized sheet metal min. thickness 0,8 mm
  - 5 ISOVER Protect BSK glue - apply on the insulation and fix it to the fire separation construction
  - 6 Clamp with threaded rod → see pages 46 to 47
- Ablative Coated Batt System HILTI\*
- 7 Mineral wool board - min. density 140 kg/m<sup>3</sup> (HILTI CFS-CT B 1S 140/50...)
  - 8 Fire stop coating - th. 1 mm (HILTI CFS-CT...) - coating is overcoated on the support construction and on the damper casing/duct
  - 9 Fire-resistant mastic - (HILTI CFS-S ACR...) fill the gap from both sides of the fire separation construction and around the perimeter of penetration and damper casing.

## Outside solid wall construction - mineral wool ROCKWOOL - mineral wool with fire-resistant coating and fire-resistant boards

EI 90 (v<sub>e</sub> i↔o) S

- For connection of following duct → see page 47
- Minimum and maximum distance between the wall and fire damper is unlimited
- When installing the insulation, follow the ROCKWOOL manufacturer's instructions
- The damper and the duct must be suspended separately
- The duct must be suspended on both sides of damper acc. to national rules
- Duct between fire damper and fire separating construction must be suspended by using threaded rods and mounting profiles, or another mounting system acc. to national standards
- Load of the suspension system depends on weight of the fire damper and duct system → see page 46
- Max. distance between two suspension systems is 1500 mm
- Duct at the point of penetration must be fixed to the fire separation structure
- Following air-conditioning duct must be suspended or supported so that all load transfer from the following duct to the fire damper is absolutely excluded. Adjacent duct must be suspended or supported, as required by the duct suppliers
- If the threaded rod is located inside the duct insulation, distance between threaded rod and duct is max 30 mm
- If the threaded rod is located outside the duct isolation, distance between threaded rod and isolation is max. 40 mm

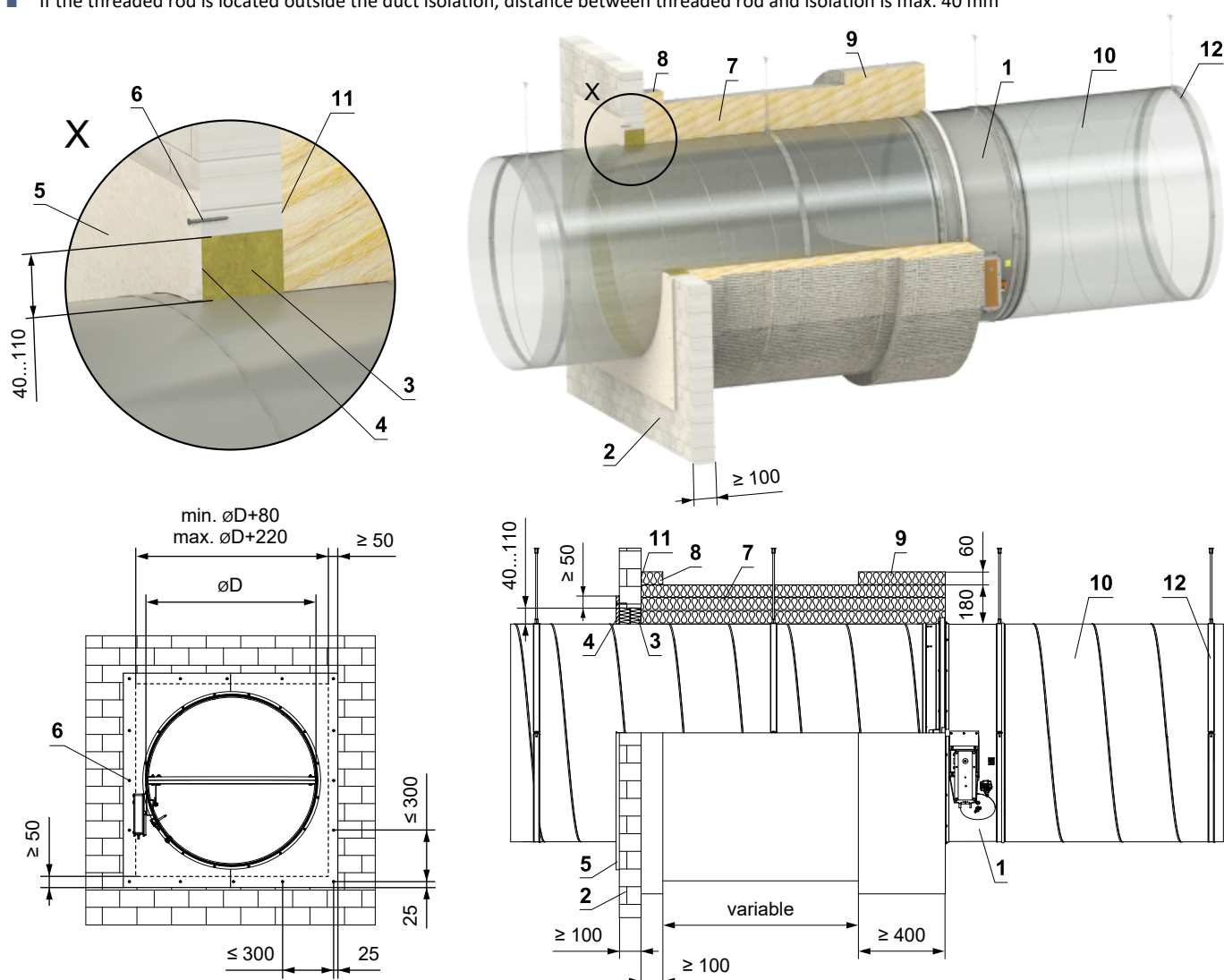

- |   |   |
|---|---|
| <p>1 FDMA-PM</p> <p>2 Solid wall construction</p> <p>3 Mineral wool board - min. density 140 kg/m<sup>3</sup> (e.g. PROMAPYR-T150, ROCKWOOL HARDROCK / STEPLOCK HD)</p> <p>4 Fire-resistant coating - th. 1 mm (e.g. PROMASTOP-I)</p> <p>5 Fire-resistant board - min. th. 15 mm, min. density 870 kg/m<sup>3</sup> (e.g. PROMATECT-H)</p> <p>6 Screw 4x50 mm - screws must be fixed in the wall construction, use steel anchors if necessary</p> | <p>7 Insulation mat made of mineral wool, with a surface treatment of aluminum foil - th. 180 mm (3x60 mm), min. density 105 kg/m<sup>3</sup> - (System ROCKWOOL Wired Mat 105 Alu)</p> <p>8 Duct penetration insulation collar - th. 60 mm (System ROCKWOOL Wired Mat 105 Alu) - glued (pos. 11) and fixed with screws to the wall construction</p> <p>9 Insulation collar of the damper and duct connection - th. 60 mm (System ROCKWOOL Wired Mat 105 Alu)</p> <p>10 Standard air duct, made of galvanized sheet metal min. thickness 0,8 mm</p> <p>11 ROCKWOOL Firepro glue - apply on the insulation and fix it to the fire separation construction</p> <p>12 Clamp with threaded rod → see pages 46 to 47</p> |
|---|---|

**Installation in gypsum wall construction**

**In gypsum wall construction - mortar or gypsum**

- For connection of following duct → see page 47
- The installation opening is lined with a UW/CW profile.

**EI 90 (v<sub>e</sub> i↔o) S**  
**EI 120 (v<sub>e</sub> i↔o) S\***

\* Requirement to EI 120 (v<sub>e</sub> i↔o) S must be specified in the order alone. Without specification is supplied standard damper EI 90 (v<sub>e</sub> i↔o) S.

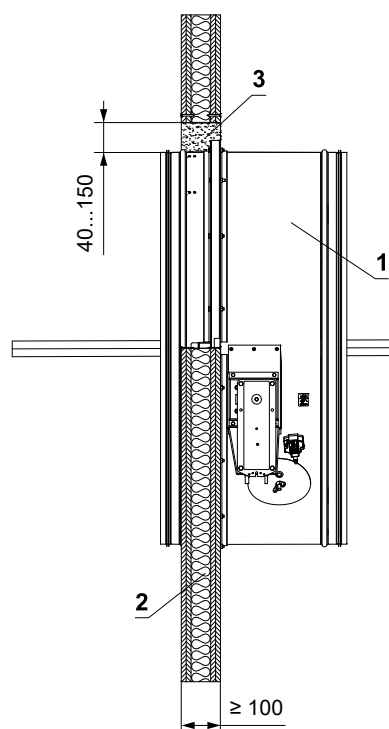
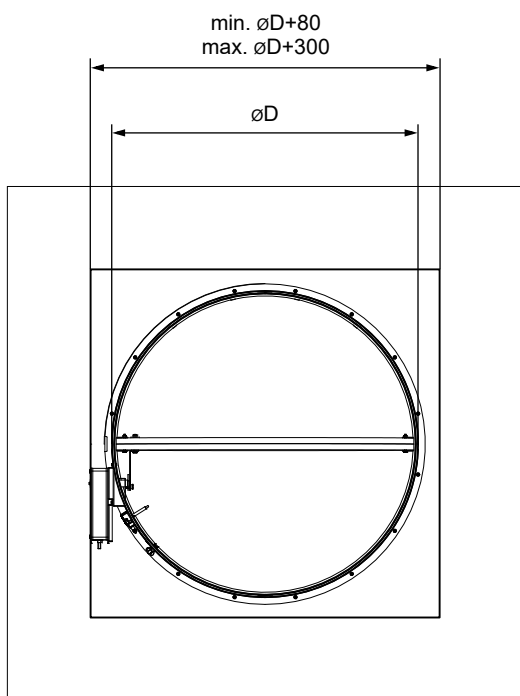
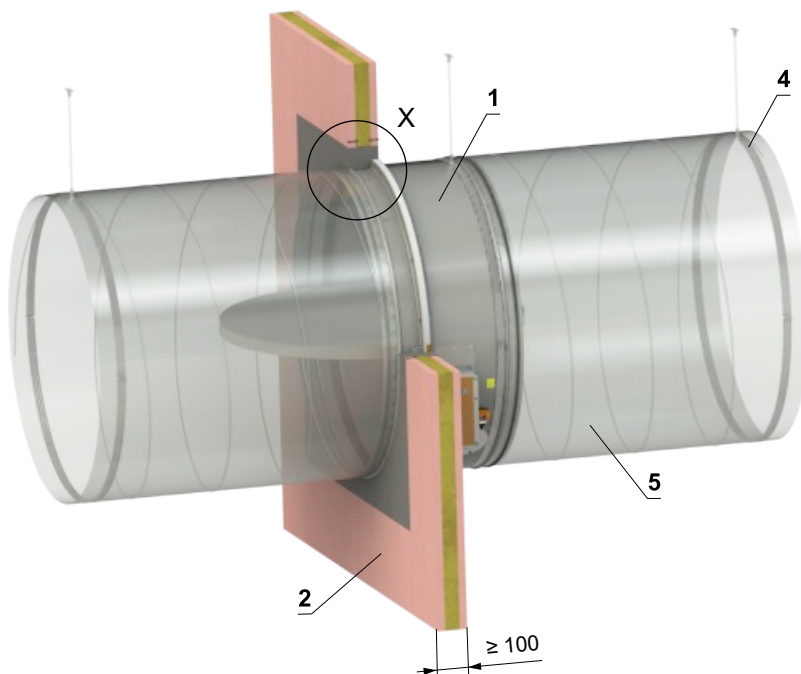
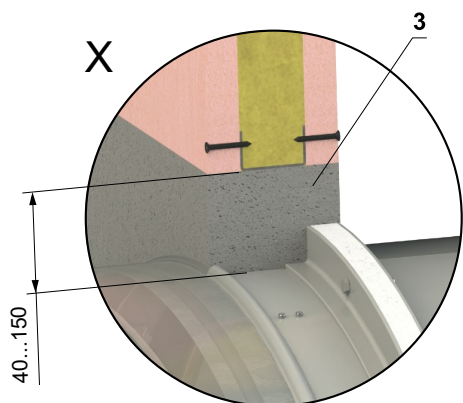

- 1 FDMA-PM
- 2 Gypsum wall construction
- 3 Mortar or gypsum
- 4 Clamp with threaded rod → see pages 46 to 47
- 5 Duct

In gypsum wall construction - 2 dampers in one opening - mortar or gypsum

EI 90 (v<sub>e</sub> i↔o) S

- For connection of following duct → see page 47
- The gap between the damper and construction is filled with mortar or gypsum
- It is possible to install up to 4 dampers symmetrically in one opening
- The installation opening is lined with a UW/CW profile.

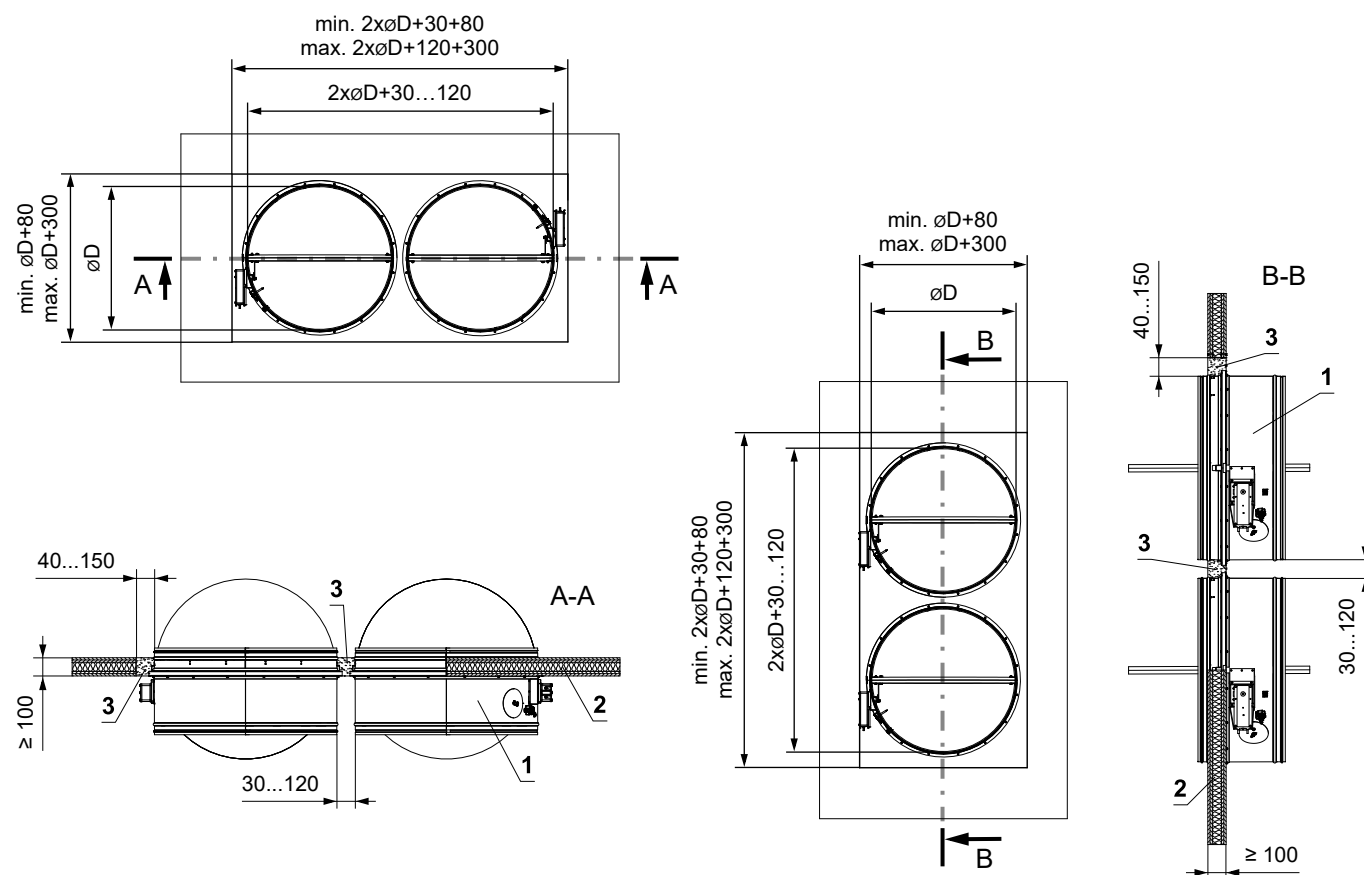
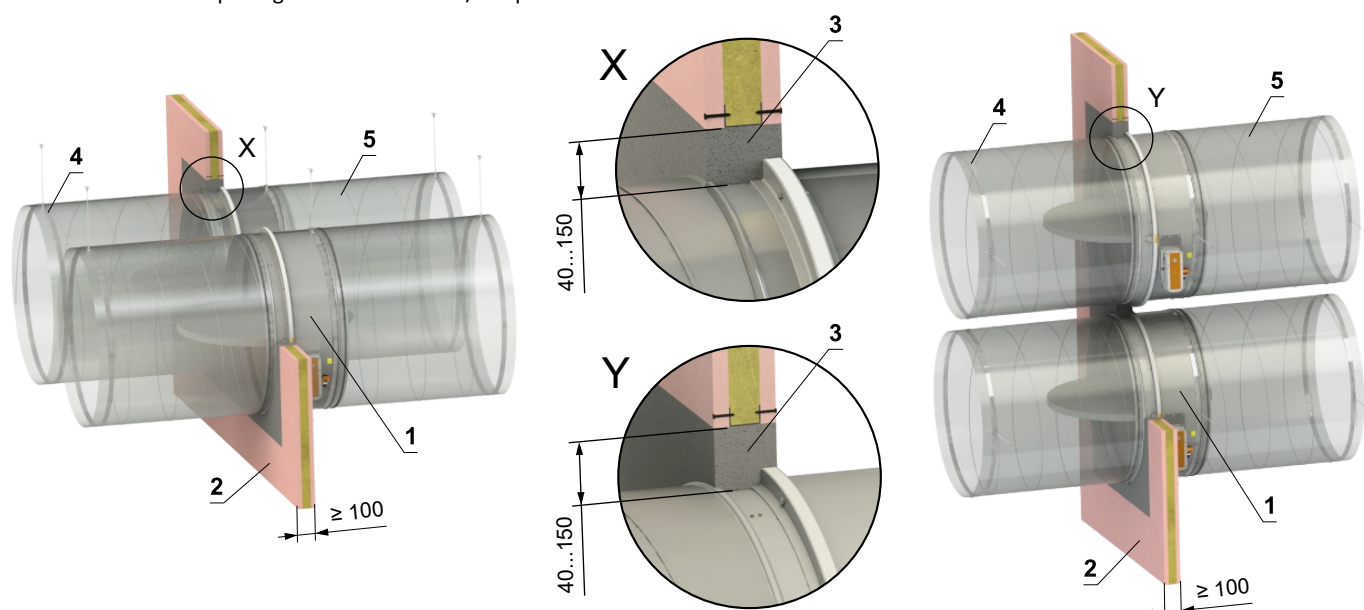

- 1 FDMA-PM
- 2 Gypsum wall construction
- 3 Mortar or gypsum
- 4 Clamp with threaded rod → see pages 46 to 47
- 5 Duct

In gypsum wall construction - Ablative Coated Batt

EI 90 (v<sub>e</sub> i↔o) S

- For connection of following duct → see page 47
- The installation opening is lined with a UW/CW profile.

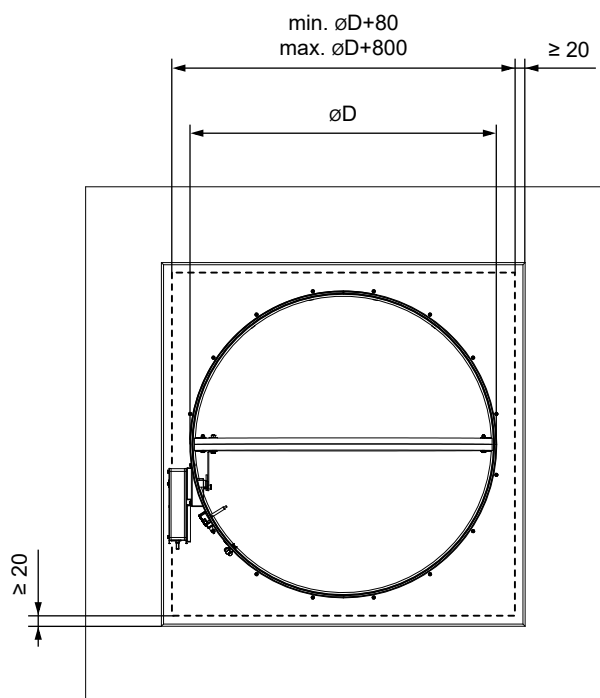
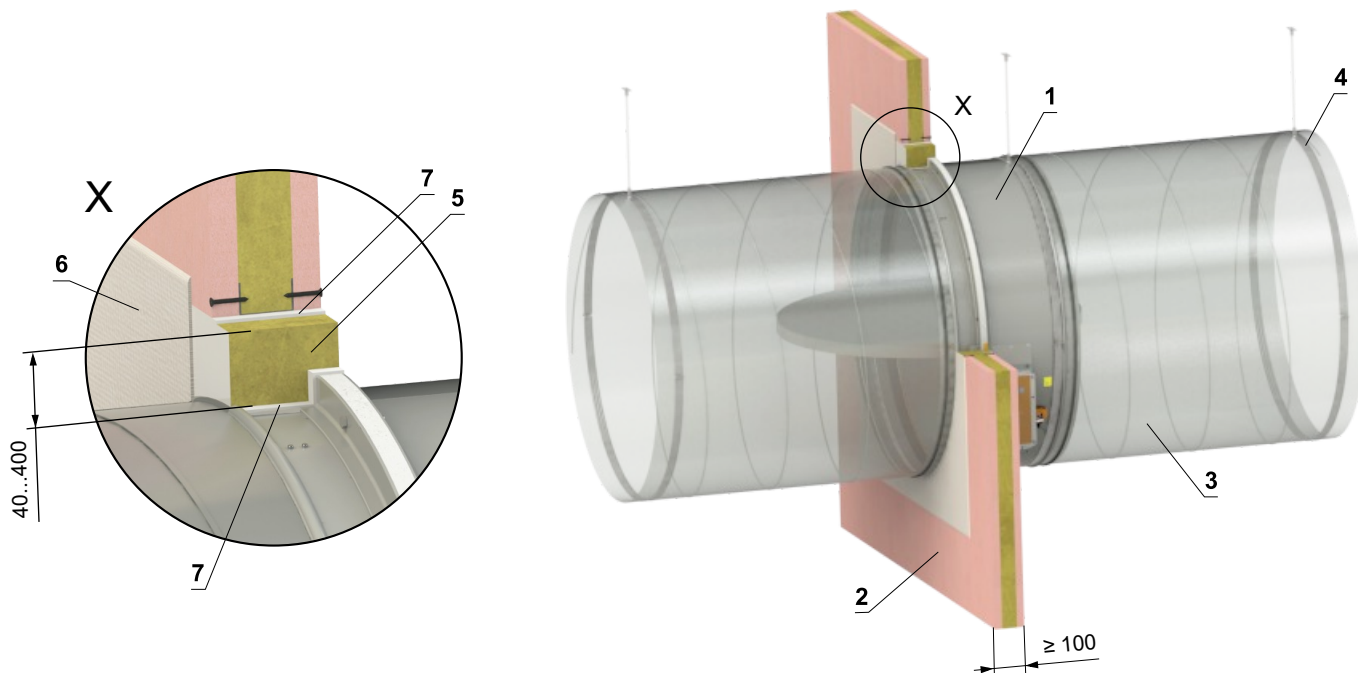

- 1 FDMA-PM
  - 2 Gypsum wall construction
  - 3 Duct
  - 4 Clamp with threaded rod → see pages 46 to 47
- Ablative Coated Batt System HILTI\*
- 5 Mineral wool board - min. density 140 kg/m<sup>3</sup> (HILTI CFS-CT B 1S 140/50...)
  - 6 Fire stop coating - th. 1 mm (HILTI CFS-CT...) - coating is overcoated on the support construction and on the damper casing/duct
  - 7 Fire-resistant mastic - (HILTI CFS-S ACR...) fill the gap from both sides of the fire separation construction and around the perimeter of penetration and damper casing.

\* HILTI system can be replaced by a similar system with the same or higher thickness, density, fire reaction class, tested according to EN 1366-3.

In gypsum wall construction - mineral wool with fire-resistant coating and fire-resistant boards

EI 90 (v<sub>e</sub> i↔o) S

- For connection of following duct → see page 47
- The installation opening is lined with a UW/CW profile.

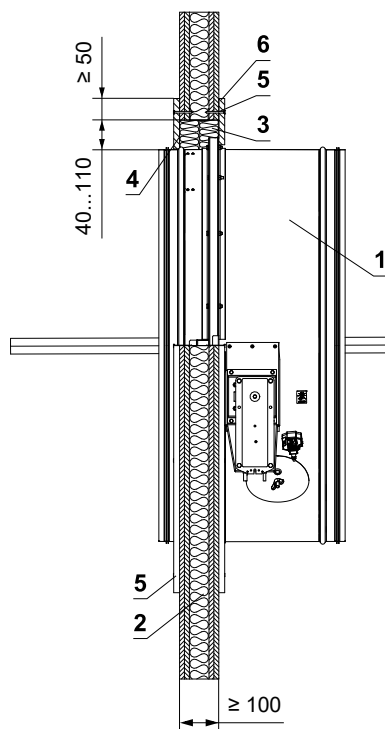
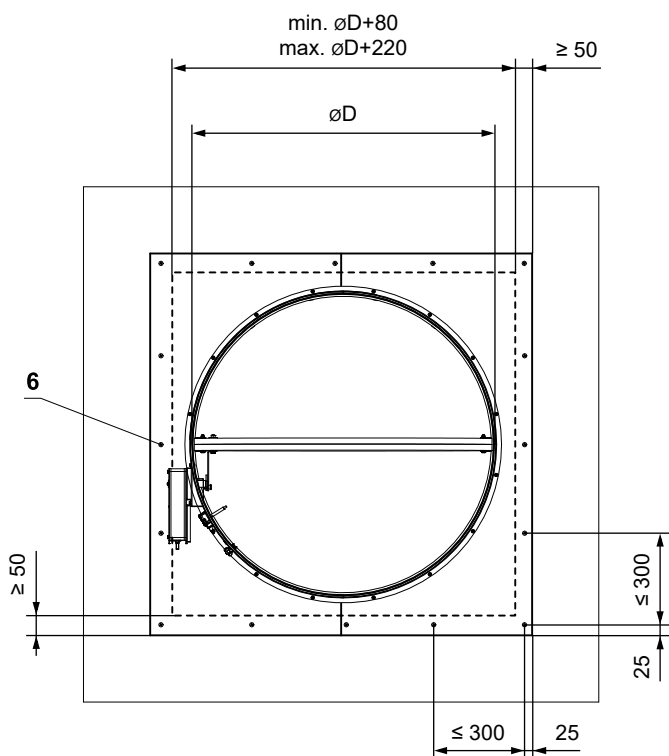
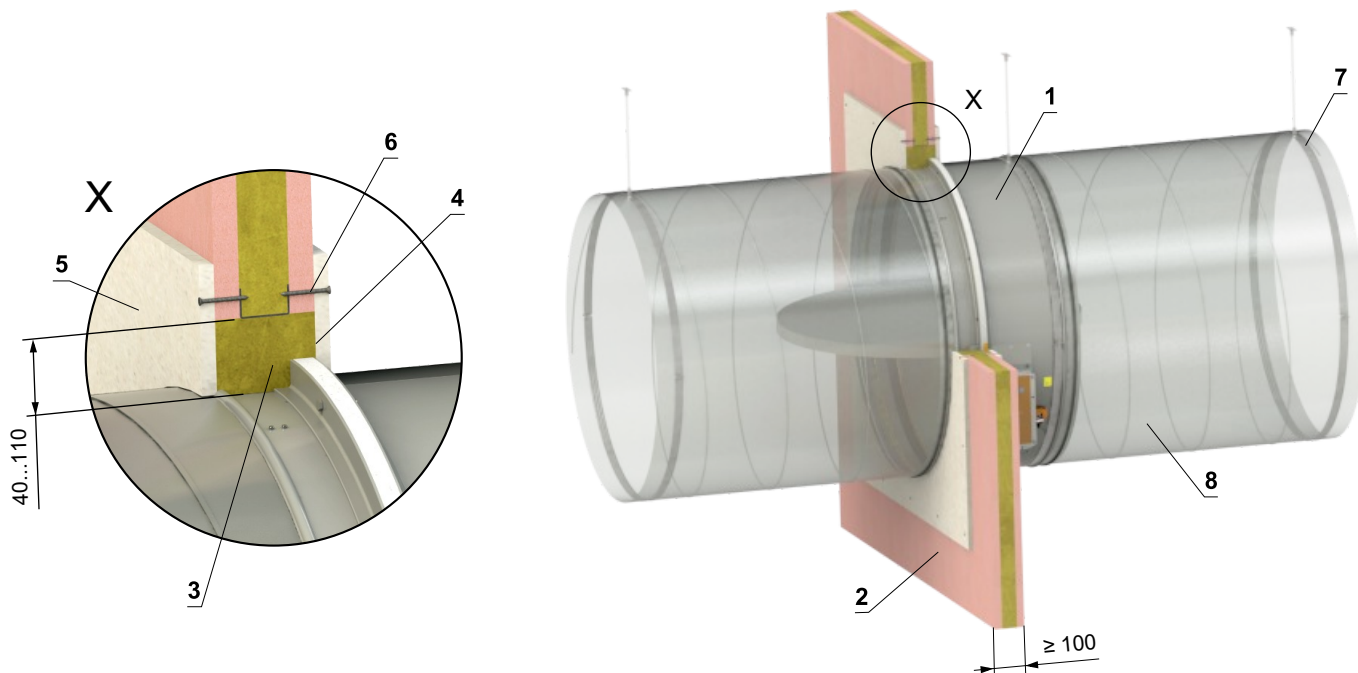

- 1 FDMA-PM
- 2 Gypsum wall construction
- 3 Mineral wool board - min. density 140 kg/m<sup>3</sup> (e.g. PROMAPYR-T150, ROCKWOOL HARDROCK / STEPROCK HD)
- 4 Fire-resistant coating - th. 1 mm (e.g. PROMASTOP-I)
- 5 Fire-resistant board - min. th. 15 mm, min. density 870 kg/m<sup>3</sup> (e.g. PROMATECT-H)
- 6 Screw 4x50 mm - screws must be fixed in the wall construction, use steel anchors if necessary
- 7 Clamp with threaded rod → see pages 46 to 47
- 8 Duct

In gypsum wall construction - installation next to the wall/ceiling - mortar or gypsum + mineral wool

EI 90 (v<sub>e</sub> i↔o) S

- For connection of following duct → see page 47
- Conditions of this installation are also valid for the installation in Solid ceiling construction.
- Penetration is filled with mortar or gypsum + mineral wool (shape, according to the location of the damper). Fix the mineral wool with glue (e.g. Promat K84 or equivalent) to the construction and damper casing
- The installation opening is lined with a UW/CW profile.

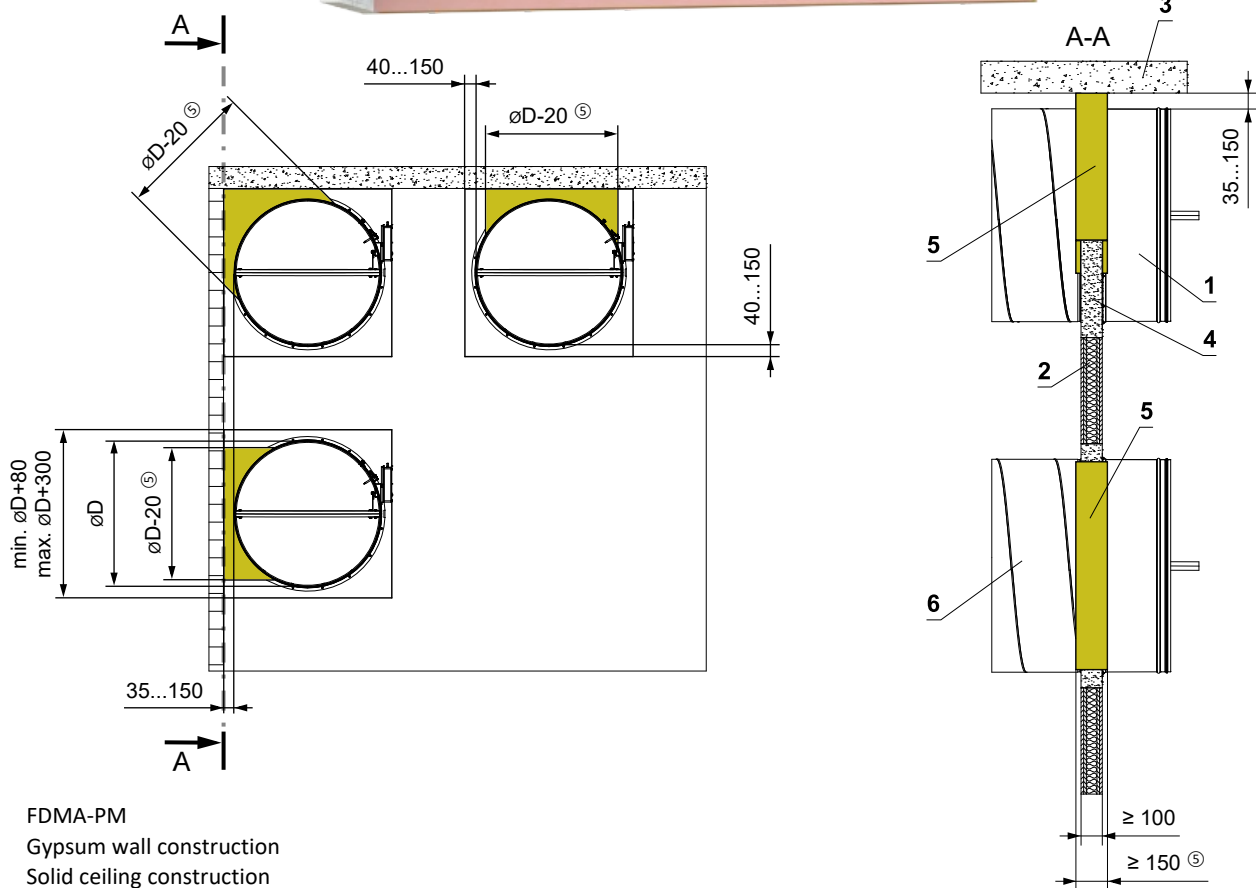
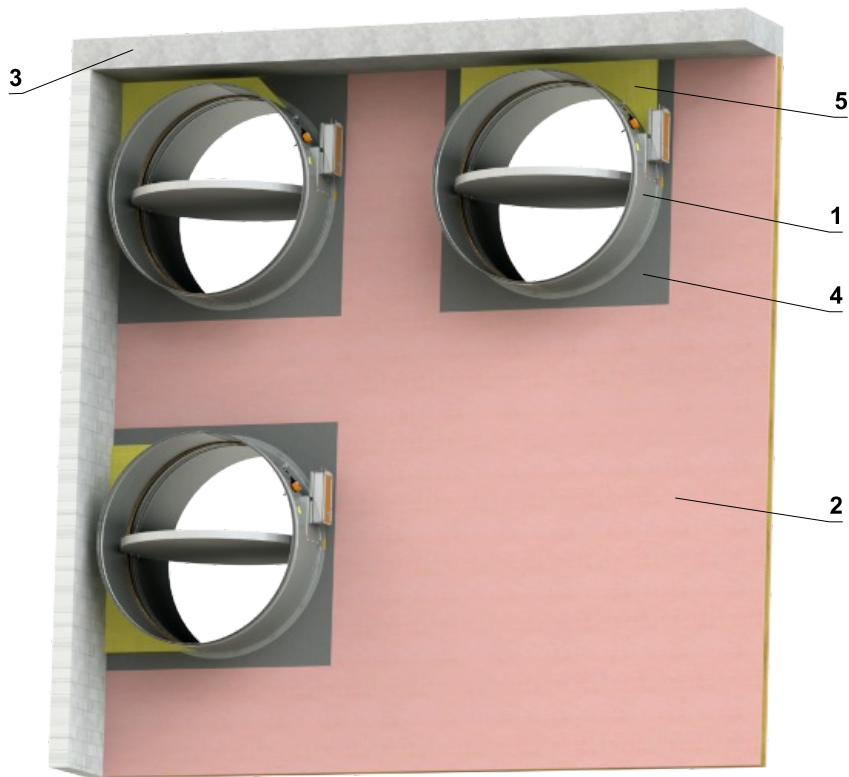

- 1 FDMA-PM
- 2 Gypsum wall construction
- 3 Solid ceiling construction
- 4 Mortar or gypsum
- 5 Mineral wool board - min. density 140 kg/m<sup>3</sup> (e.g. PROMAPYR-T150, ROCKWOOL HARDROCK / STEPROCK HD)
- 6 Duct

In gypsum wall construction - installation next to the wall/ceiling - mortar or gypsum

EI 90 (v<sub>e</sub> i↔o) S

- For connection of following duct → see page 47
- Conditions of this installation are also valid for the installation in Solid ceiling construction.
- The installation opening is lined with a UW/CW profile.

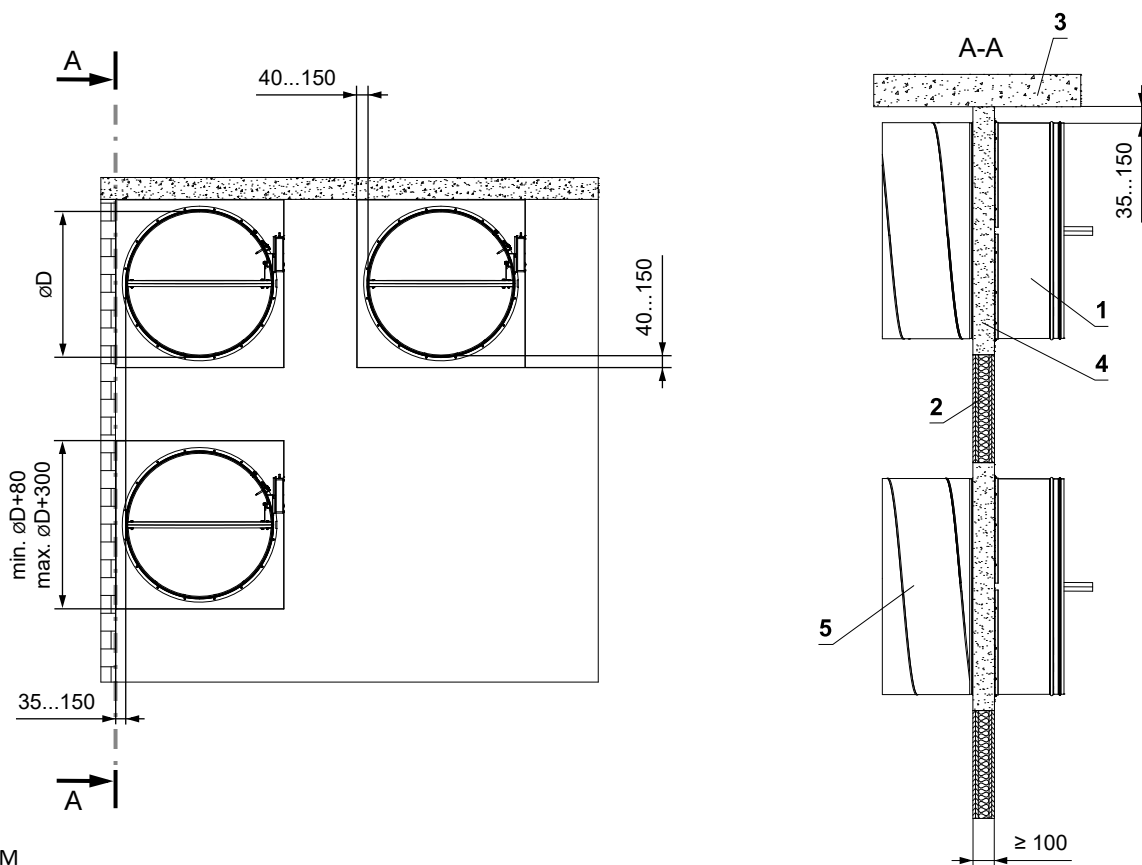
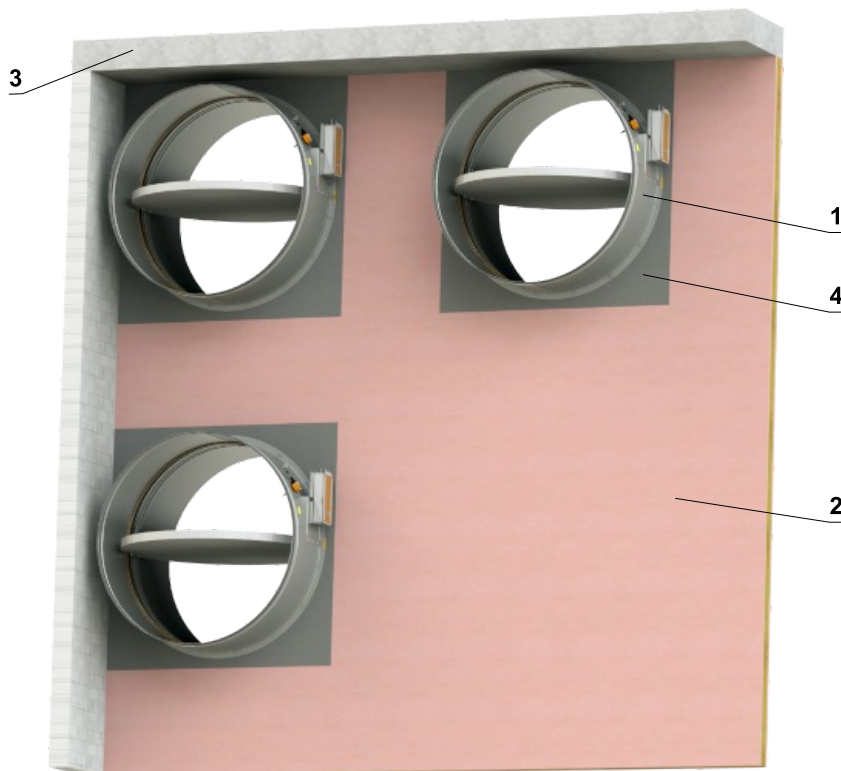

- 1 FDMA-PM
- 2 Gypsum wall construction
- 3 Solid ceiling construction
- 4 Mortar or gypsum
- 5 Duct

## Installation outside gypsum wall construction

### Outside gypsum wall construction - ISOVER Ultimate Protect - mortar or gypsum

EI 45 (v<sub>e</sub> i↔o) S

- For connection of following duct → see page 47
- Minimum and maximum distance between the wall and fire damper is unlimited
- When installing the insulation, follow the ISOVER manufacturer's instructions
- The damper and the duct must be suspended separately
- The duct must be suspended on both sides of damper acc. to national rules
- Duct between fire damper and fire separating construction must be suspended by using threaded rods and mounting profiles, or another mounting system acc. to national standards
- Load of the suspension system depends on weight of the fire damper and duct system → see page 46
- Max. distance between two suspension systems is 1500 mm
- Following air-conditioning duct must be suspended or supported so that all load transfer from the following duct to the fire damper is absolutely excluded. Adjacent duct must be suspended or supported, as required by the duct suppliers
- If the threaded rod is located inside the duct insulation, distance between threaded rod and duct is max 30 mm
- If the threaded rod is located outside the duct isolation, distance between threaded rod and isolation is max. 40 mm
- The installation opening is lined with a UW/CW profile.

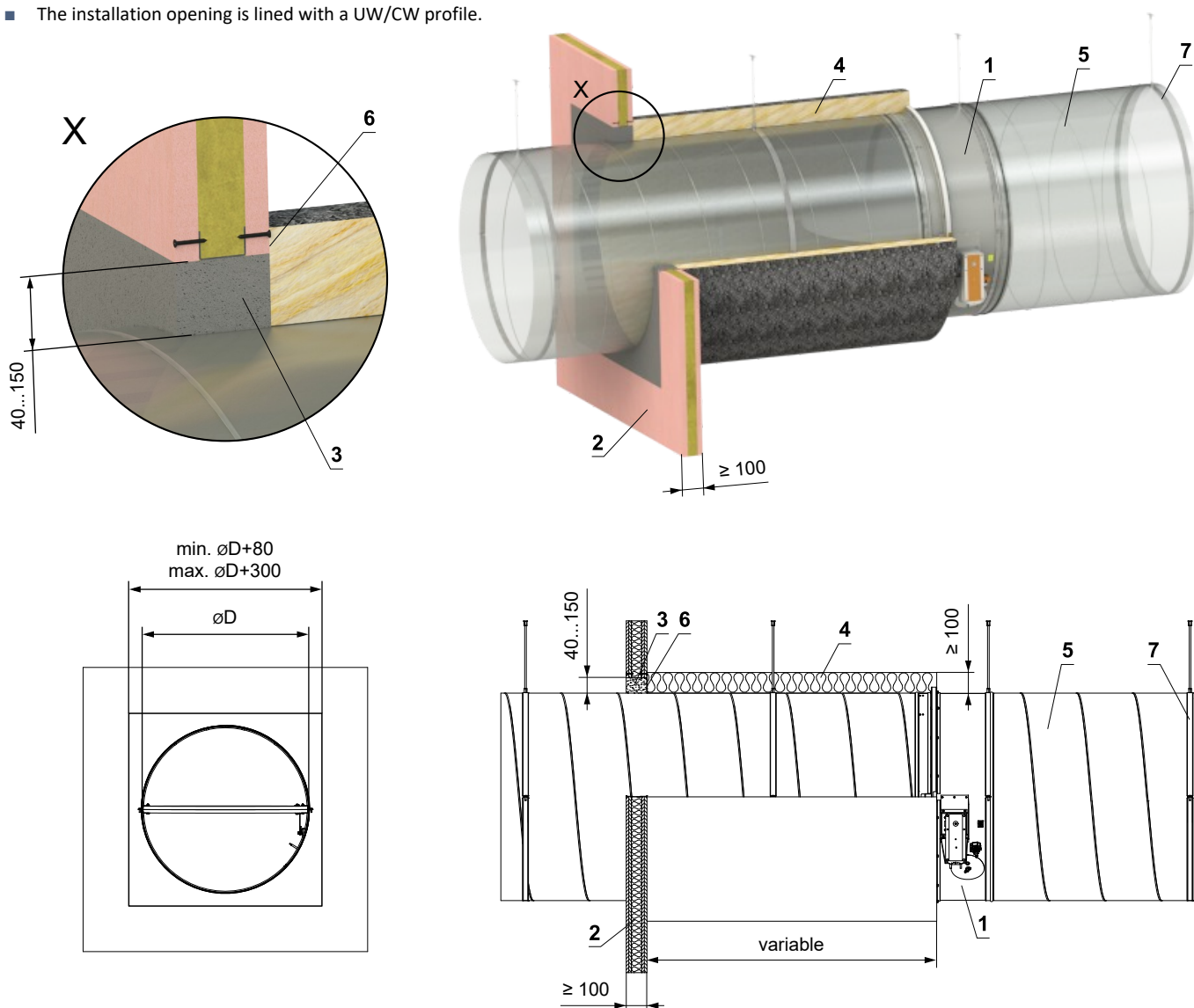

- 1 FDMA-PM
- 2 Gypsum wall construction
- 3 Mortar or gypsum
- 4 Insulation board made of mineral wool, with a surface treatment of aluminum foil, min. density 66 kg/m<sup>3</sup> (System ISOVER Ultimate Protect Wired Mat 4.0 Alu1)
- 5 Standard air duct, made of galvanized sheet metal min. thickness 0,8 mm
- 6 ISOVER Protect BSK glue - apply on the insulation and fix it to the fire separation construction
- 7 Clamp with threaded rod → see pages 46 to 47

Outside gypsum wall construction - ISOVER Ultimate Protect - Ablative Coated Batt

EI 45 (v<sub>e</sub> i↔o) S

- For connection of following duct → see page 47
- Minimum and maximum distance between the wall and fire damper is unlimited
- When installing the insulation, follow the ISOVER manufacturer's instructions
- The damper and the duct must be suspended separately
- The duct must be suspended on both sides of damper acc. to national rules
- Duct between fire damper and fire separating construction must be suspended by using threaded rods and mounting profiles, or another mounting system acc. to national standards
- Load of the suspension system depends on weight of the fire damper and duct system → see page 46
- Max. distance between two suspension systems is 1500 mm
- Duct at the point of penetration must be fixed to the fire separation structure
- Following air-conditioning duct must be suspended or supported so that all load transfer from the following duct to the fire damper is absolutely excluded. Adjacent duct must be suspended or supported, as required by the duct suppliers
- If the threaded rod is located inside the duct insulation, distance between threaded rod and duct is max 30 mm
- If the threaded rod is located outside the duct isolation, distance between threaded rod and isolation is max. 40 mm
- The installation opening is lined with a UW/CW profile.

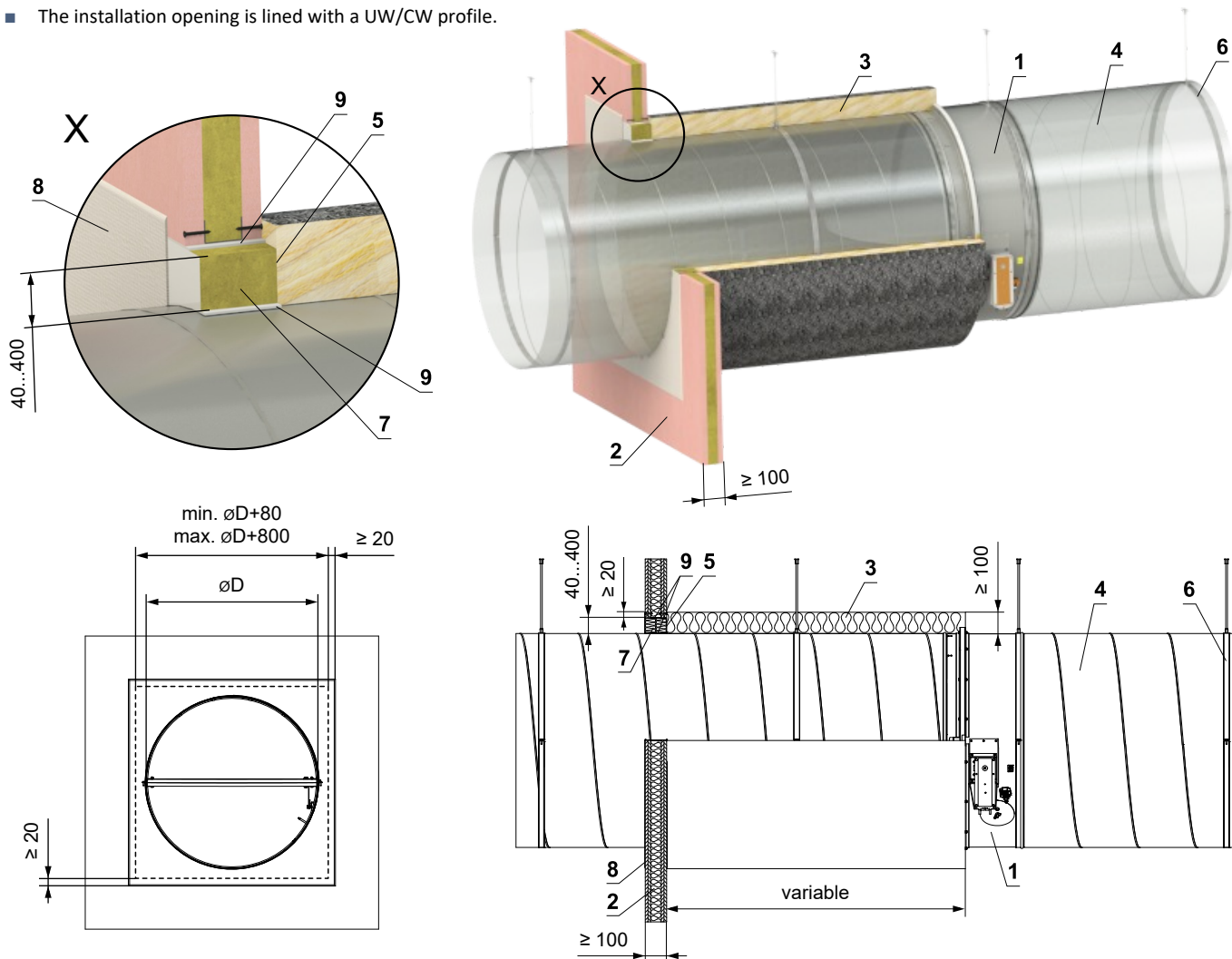

- 1 FDMA-PM
  - 2 Gypsum wall construction
  - 3 Insulation board made of mineral wool, with a surface treatment of aluminum foil, min. density 66 kg/m<sup>3</sup> (System ISOVER Ultimate Protect Wired Mat 4.0 Alu1)
  - 4 Standard air duct, made of galvanized sheet metal min. thickness 0,8 mm
  - 5 ISOVER Protect BSK glue - apply on the insulation and fix it to the fire separation construction
  - 6 Clamp with threaded rod → see pages 46 to 47
- Ablative Coated Batt System HILTI\*
- 7 Mineral wool board - min. density 140 kg/m<sup>3</sup> (HILTI CFS-CT B 1S 140/50...)
  - 8 Fire stop coating - th. 1 mm (HILTI CFS-CT...) - coating is overcoated on the support construction and on the damper casing/duct
  - 9 Fire-resistant mastic - (HILTI CFS-S ACR...) fill the gap from both sides of the fire separation construction and around the perimeter of penetration and damper casing.

\* HILTI system can be replaced by a similar system with the same or higher thickness, density, fire reaction class, tested according to EN 1366-3.

**Outside gypsum wall construction - mineral wool ROCKWOOL - mineral wool with fire-resistant coating and fire-resistant boards**

**EI 90 (v<sub>e</sub> i↔o) S**

- For connection of following duct → see page 47
- Minimum and maximum distance between the wall and fire damper is unlimited
- When installing the insulation, follow the ROCKWOOL manufacturer's instructions
- The damper and the duct must be suspended separately
- The duct must be suspended on both sides of damper acc. to national rules
- Duct between fire damper and fire separating construction must be suspended by using threaded rods and mounting profiles, or another mounting system acc. to national standards
- Load of the suspension system depends on weight of the fire damper and duct system → see page 46
- Max. distance between two suspension systems is 1500 mm
- Duct at the point of penetration must be fixed to the fire separation structure
- Following air-conditioning duct must be suspended or supported so that all load transfer from the following duct to the fire damper is absolutely excluded. Adjacent duct must be suspended or supported, as required by the duct suppliers
- If the threaded rod is located inside the duct insulation, distance between threaded rod and duct is max 30 mm
- If the threaded rod is located outside the duct isolation, distance between threaded rod and isolation is max. 40 mm
- The installation opening is lined with a UW/CW profile.

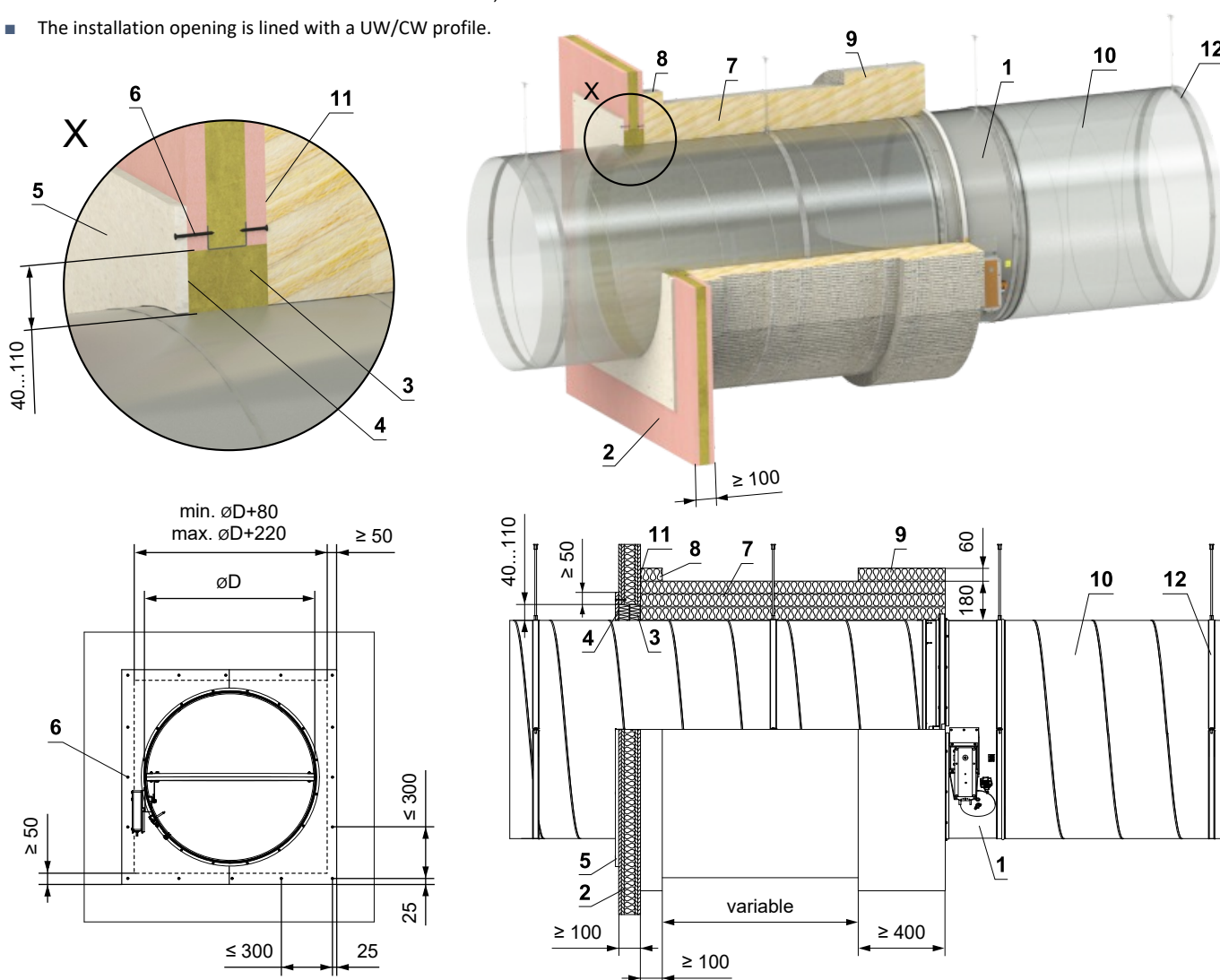

- |  |   |
|--|---|
| <p>1 FDMA-PM</p> <p>2 Gypsum wall construction</p> <p>3 Mineral wool board - min. density 140 kg/m<sup>3</sup> (e.g. PROMAPYR-T150, ROCKWOOL HARDROCK / STEPROCK HD)</p> <p>4 Fire-resistant coating - th. 1 mm (e.g. PROMASTOP-I)</p> <p>5 Fire-resistant board - min. th. 15 mm, min. density 870 kg/m<sup>3</sup> (e.g. PROMATECT-H)</p> <p>6 Screw 4x50 mm - screws must be fixed in the wall construction, use steel anchors if necessary</p> | <p>7 Insulation mat made of mineral wool, with a surface treatment of aluminum foil - th. 180 mm (3x60 mm), min. density 105 kg/m<sup>3</sup> - (System ROCKWOOL Wired Mat 105 Alu)</p> <p>8 Duct penetration insulation collar - th. 60 mm (System ROCKWOOL Wired Mat 105 Alu) - glued (pos. 11) and fixed with screws to the wall construction</p> <p>9 Insulation collar of the damper and duct connection - th. 60 mm (System ROCKWOOL Wired Mat 105 Alu)</p> <p>10 Standard air duct, made of galvanized sheet metal min. thickness 0,8 mm</p> <p>11 ROCKWOOL Firepro glue - apply on the insulation and fix it to the fire separation construction</p> <p>12 Clamp with threaded rod → see pages 46 to 47</p> |
|--|---|

## Shaft walls

### Rigips

- Shaft wall is a vertical, non-bearing partition construction meeting the double-sided fire requirements. The shaft wall can be mounted only from one side. No mineral insulation is used in the construction.
- First of all, the shaft wall construction must be laid out. Apart from other vertical constructions, the perimeter sections must be fitted with connection sealing made from A1 or A2 fire reaction materials (for instance floor strips Orsil N/PP). The perimeter sections must be anchored using steel plugs  $\varnothing$  6 mm (for example DN6 or ZHOP) with 500 mm span.
- Sheathing is carried out using two layers of Glasroc F boards Ridurit with 20 mm thickness, the boards are oriented horizontally. First sheathing layer is fixed with TN 212 screws in spacing 200mm to the support construction. The boards are mounted to tight butt joints without need of cementing. The second sheathing layer is screwed to the first sheathing layer using screws Rodurit in square net 250 mm. Reset of joints of the first and second layer of Ridurit sheathing is set to 600 mm vertically and 300 mm horizontally.

### Assembly with support structure

- Vertical intermediate R-CW sections are fixed in 1000 mm layout spacing between R-UW sections and vertical perimeter R-CW sections.

### Assembly without support structure

- Maximum width of the shaft wall is 2 metres in this case (board length). Steel squares made from steel galvanized sheet metal 40/20/1 mm are used as perimeter sections, they are anchored to bearing wall using  $\varnothing$  6 mm steel plugs (for example DN6 or ZHOP) with 500 mm spacing.

Assembly with support structure

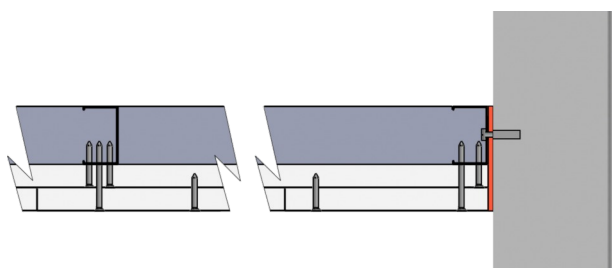

Assembly without support structure

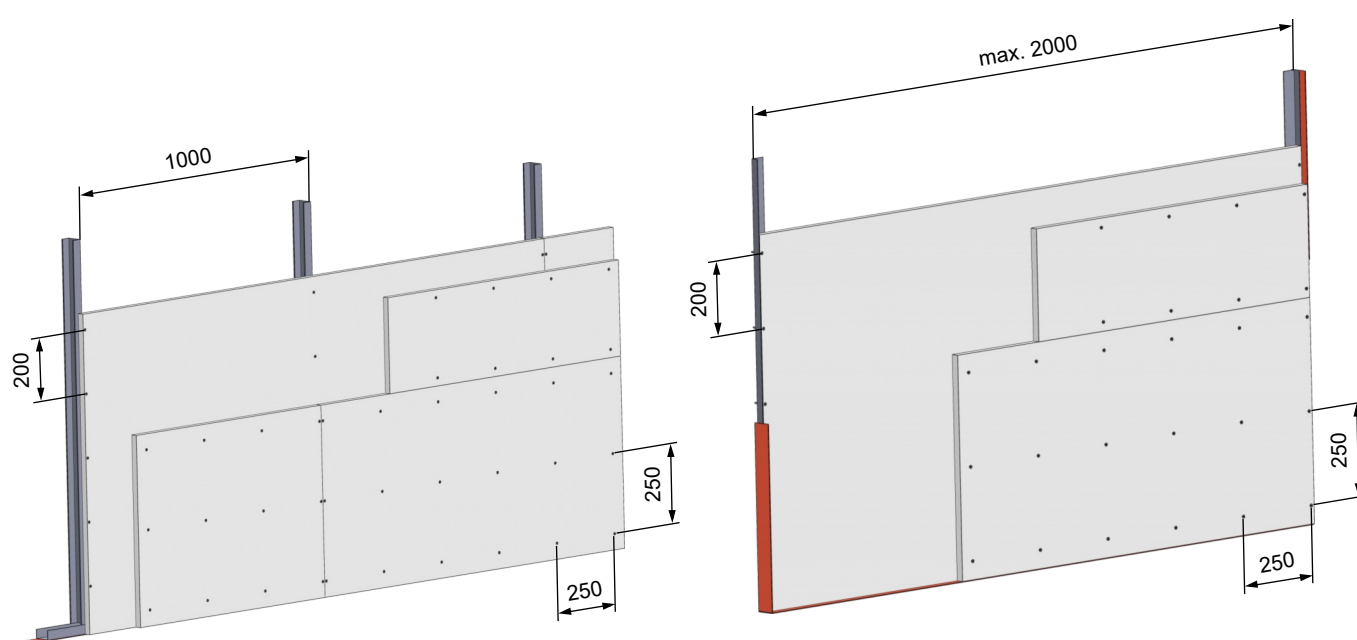
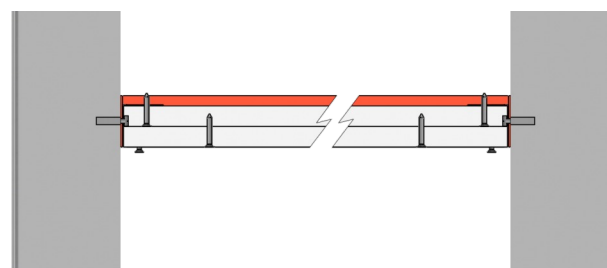

- Rigips solution is shown here as an example. Alternatively it is possible to apply the solution from Knauf or Promat. In such a case follow the instructions of the producer.

In shaft wall Rigips - mortar or gypsum

- For connection of following duct → see page 47
- Follow shaft wall manufacturer's instructions
- All technical specifications and conditions can be found at [www.rigips.cz](http://www.rigips.cz)

EI 90 (v<sub>e</sub> i↔o) S

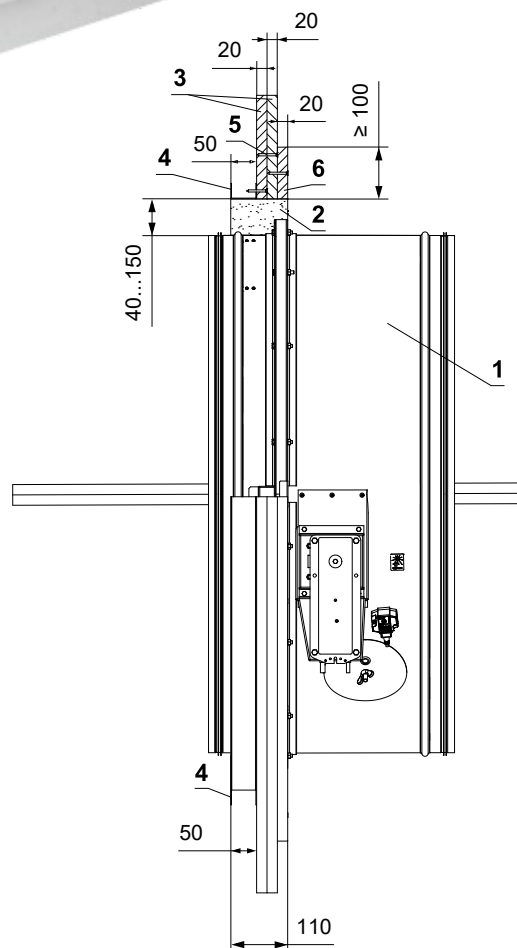
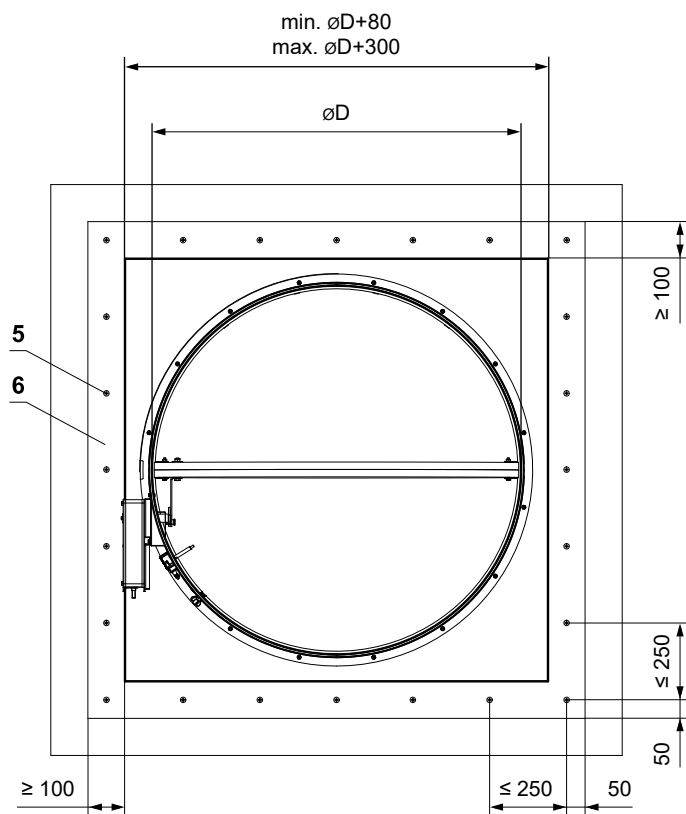
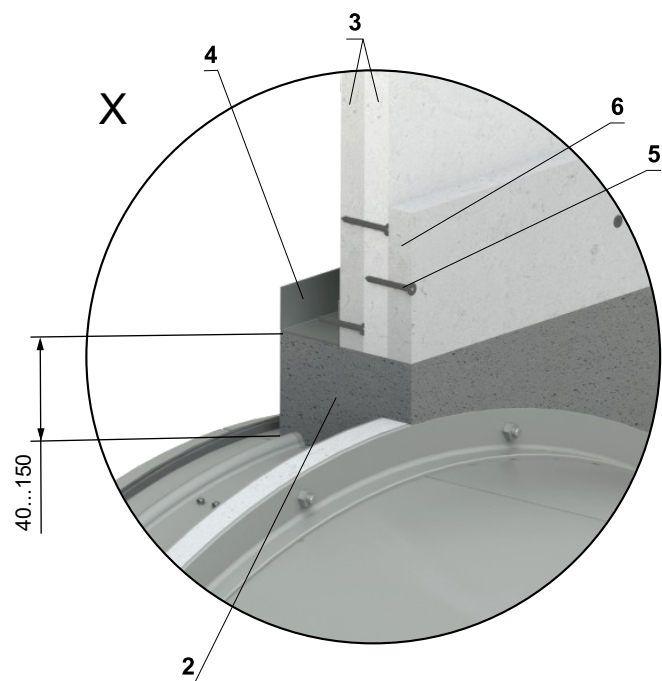

- 1 FDMA-PM
- 2 Mortar or gypsum
- 3 Fire-resistant board th. 20 mm Rigips Glasroc F Ridurit
- 4 Steel U-profile Rigips R-UW 50 or Rigips R-CW 50
- 5 Screw Rigips Ridurit TX 3,5x35 mm
- 6 Additional fire-resistant board th. 20 mm Rigips Glasroc F Ridurit

### Installation in solid ceiling construction

#### In solid ceiling construction - mortar or gypsum

- For connection of following duct → see page 47
- The damper can be installed from both sides of the construction, i.e. from the top or the bottom side of the ceiling.

El 90 (h<sub>o</sub> i↔o) S  
El 120 (h<sub>o</sub> i↔o) S\*

\* Requirement to El 120 (h<sub>o</sub> i↔o) S must be specified in the order alone. Without specification is supplied standard damper El 90 (h<sub>o</sub> i↔o) S.

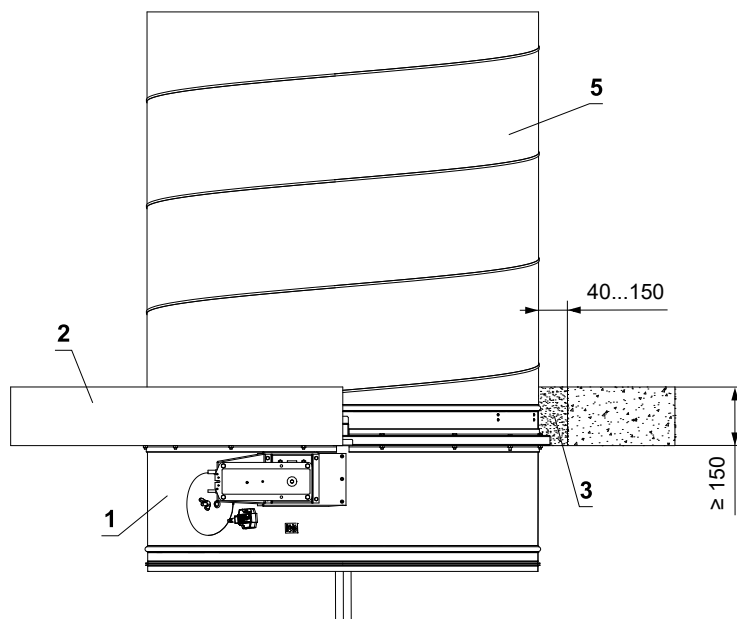
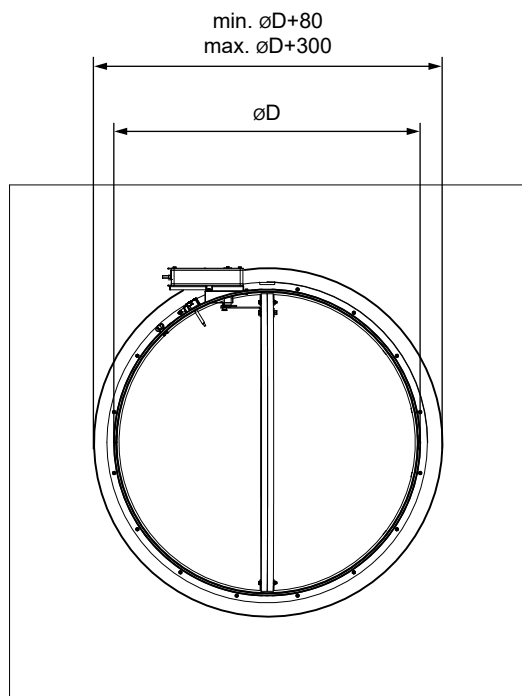
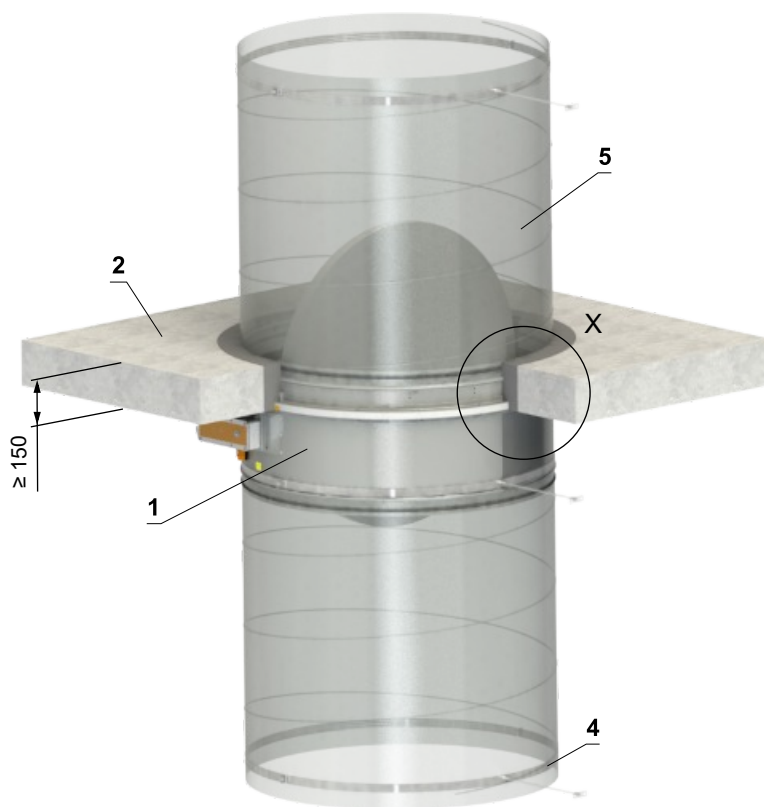
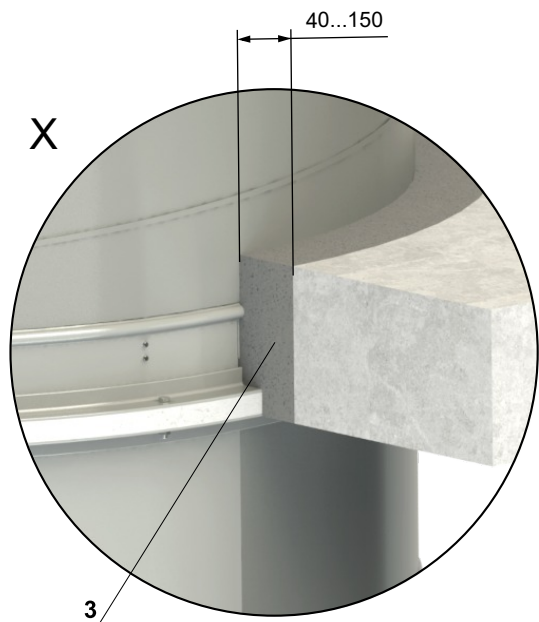

- 1 FDMA-PM
- 2 Solid ceiling construction
- 3 Mortar or gypsum
- 4 Clamp with threaded rod → see pages 46 to 47
- 5 Duct

In solid ceiling construction - 2 dampers in one opening - mortar or gypsum

EI 90 (h<sub>o</sub> i↔o) S

- For connection of following duct → see page 47
- The gap between the damper and construction is filled with mortar or gypsum
- It is possible to install up to 4 dampers symmetrically in one opening
- The damper can be installed from both sides of the construction, i.e. from the top or the bottom side of the ceiling.

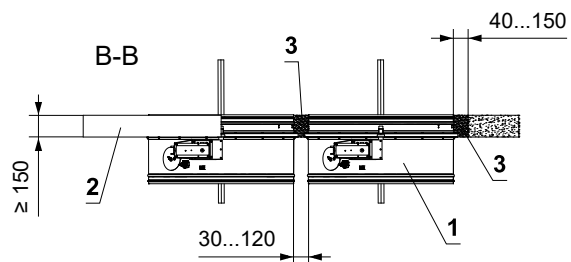
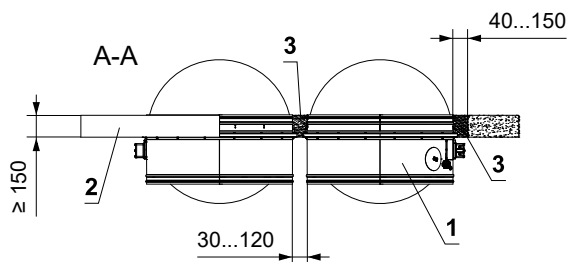
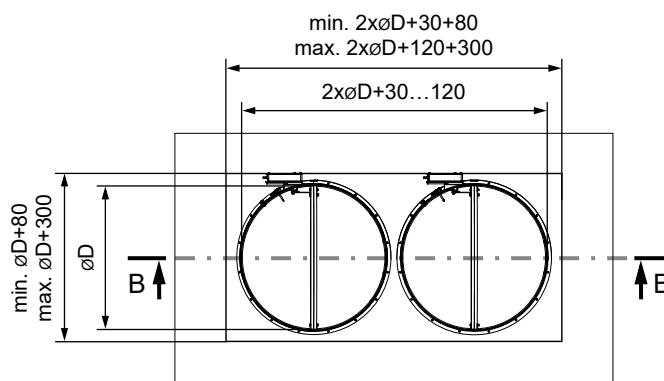
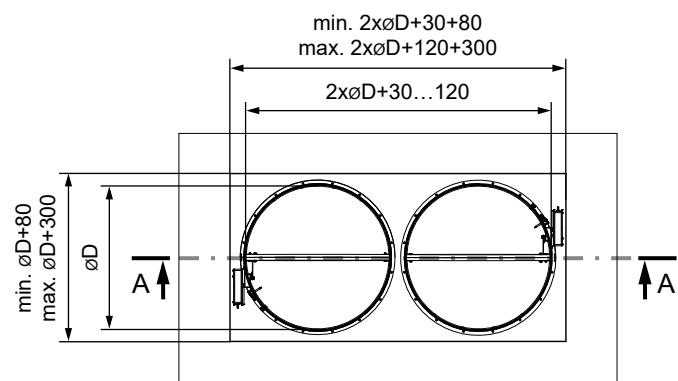
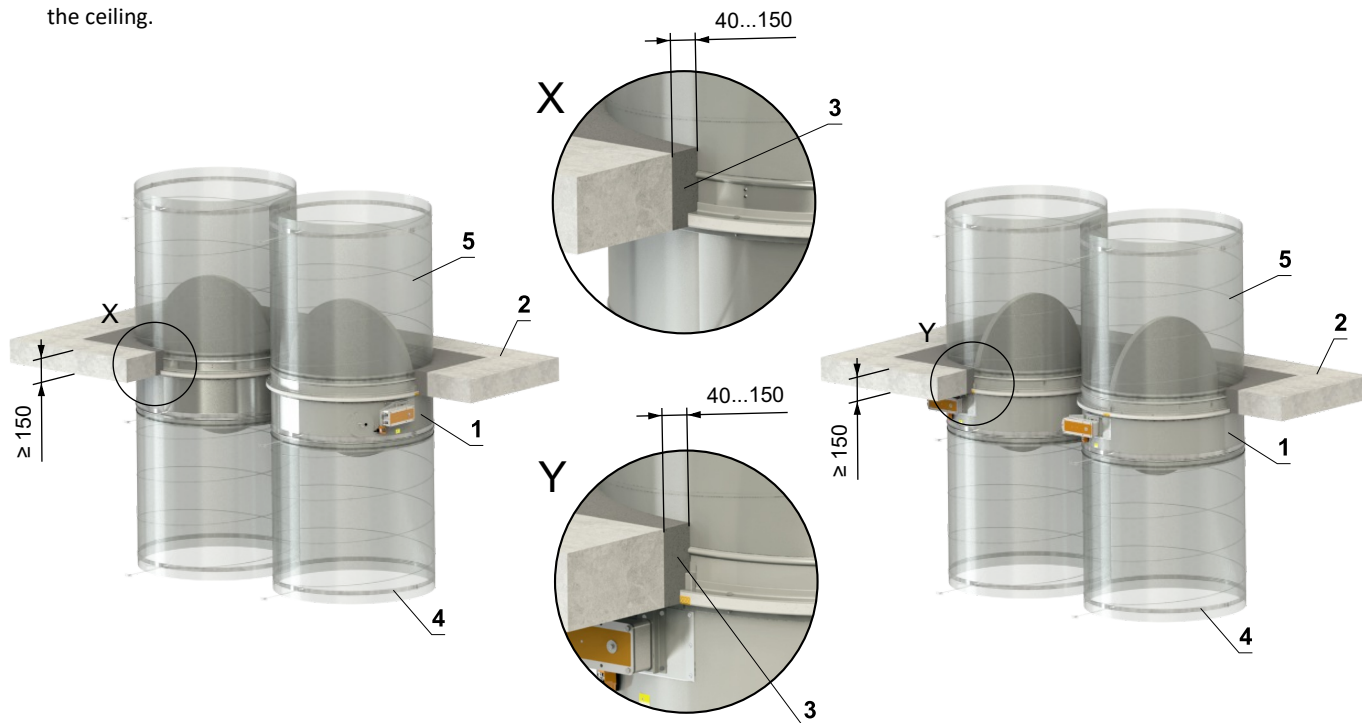

- 1 FDMA-PM
- 2 Solid ceiling construction
- 3 Mortar or gypsum
- 4 Clamp with threaded rod → see pages 46 to 47
- 5 Duct

In solid ceiling construction - Ablative Coated Batt

EI 90 (h<sub>o</sub> i↔o) S

- For connection of following duct → see page 47
- The damper can be installed from both sides of the construction, i.e. from the top or the bottom side of the ceiling.

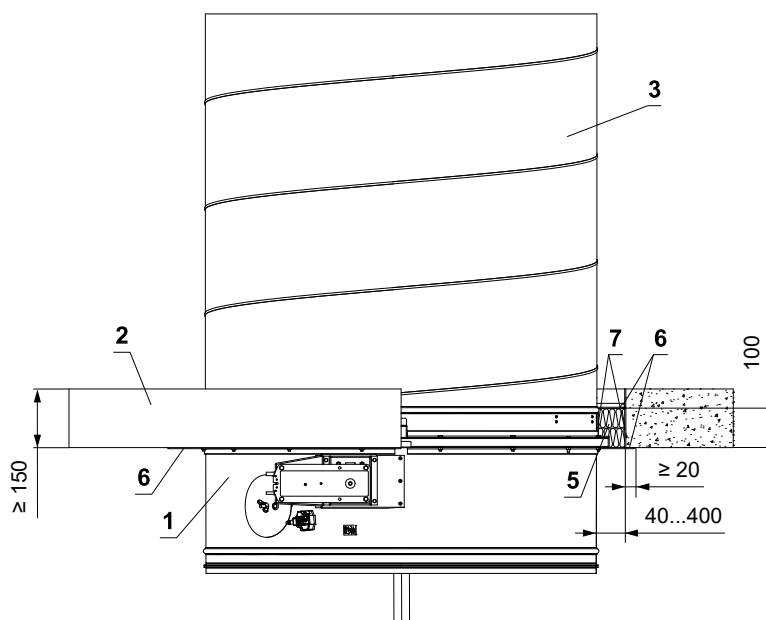
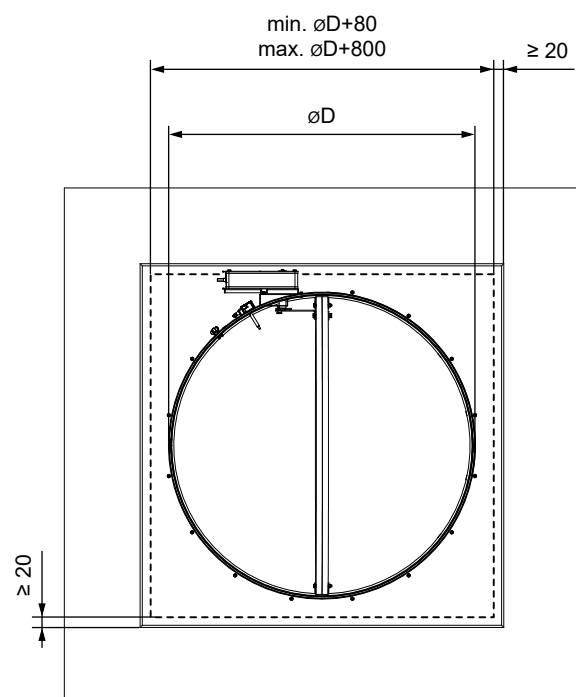
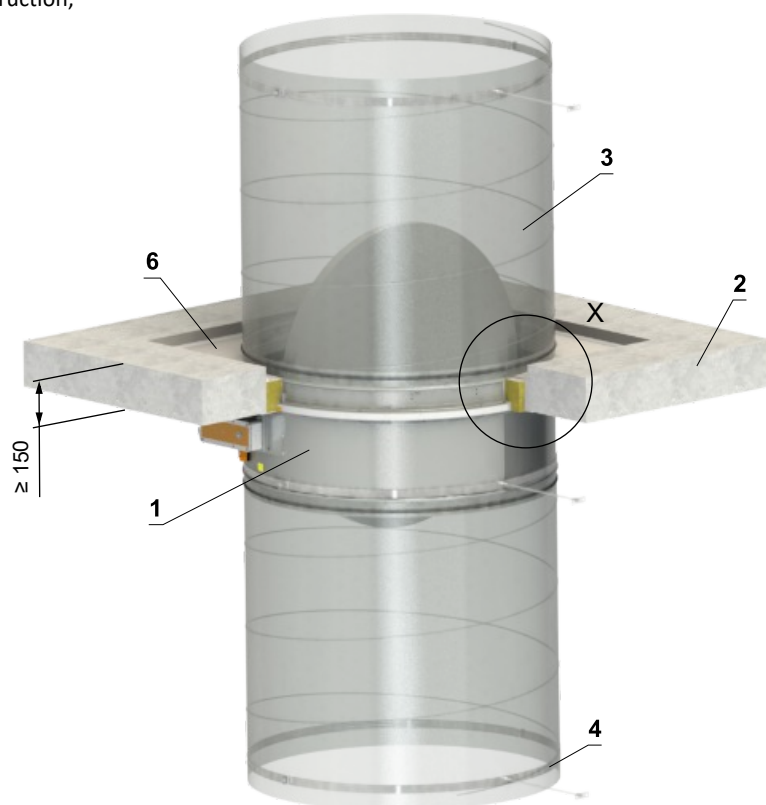
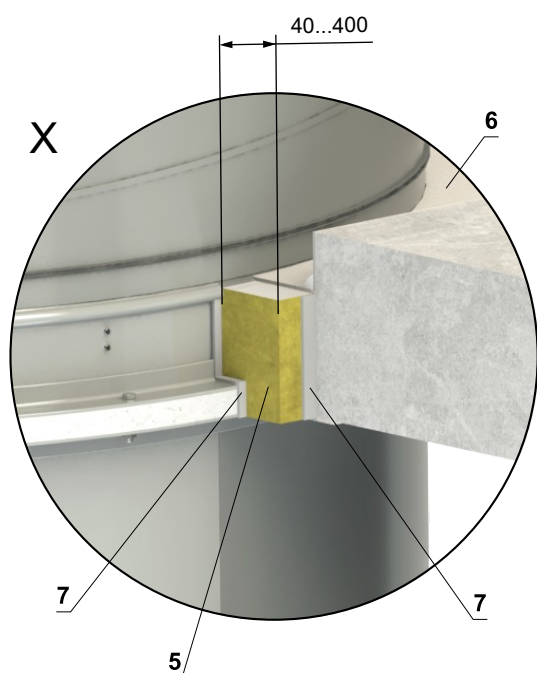

- 1 FDMA-PM
- 2 Solid ceiling construction
- 3 Duct
- 4 Clamp with threaded rod → see pages 46 to 47  
Ablative Coated Batt System HILTI\*
- 5 Mineral wool board - min. density 140 kg/m<sup>3</sup> (HILTI CFS-CT B 1S 140/50...)
- 6 Fire stop coating - th. 1 mm (HILTI CFS-CT...) - coating is overcoated on the support construction and on the damper casing/duct
- 7 Fire-resistant mastic - (HILTI CFS-S ACR...) fill the gap from both sides of the fire separation construction and around the perimeter of penetration and damper casing.

\* HILTI system can be replaced by a similar system with the same or higher thickness, density, fire reaction class, tested according to EN 1366-3.

In solid ceiling construction - mineral wool with fire-resistant coating and fire-resistant boards

EI 90 (h<sub>o</sub> i↔o) S

- For connection of following duct → see page 47
- The damper can be installed from both sides of the construction, i.e. from the top or the bottom side of the ceiling.

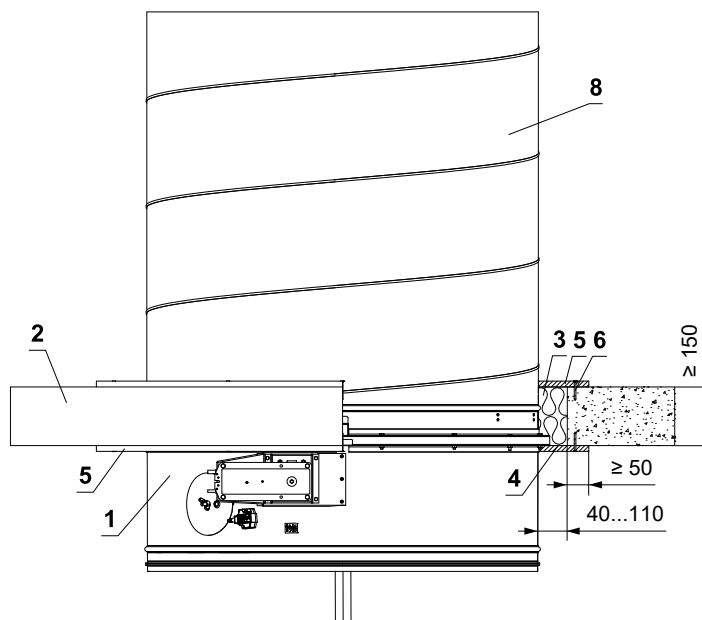
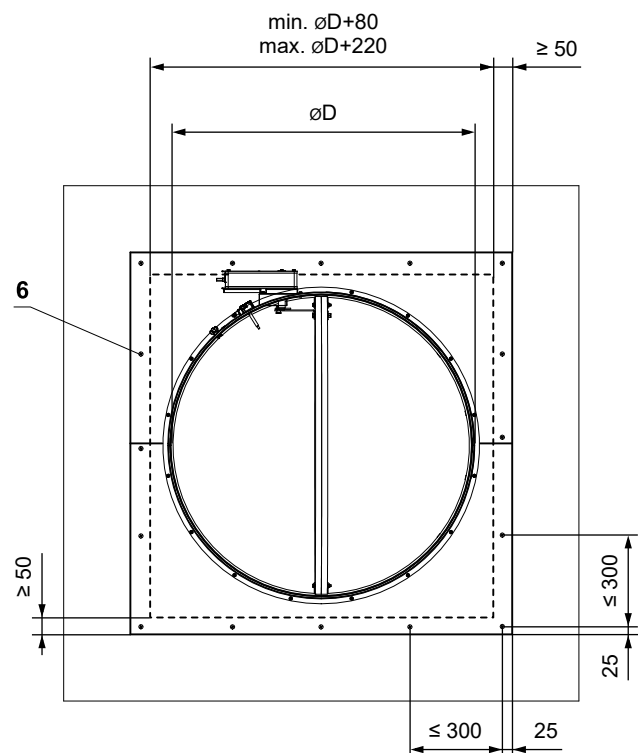
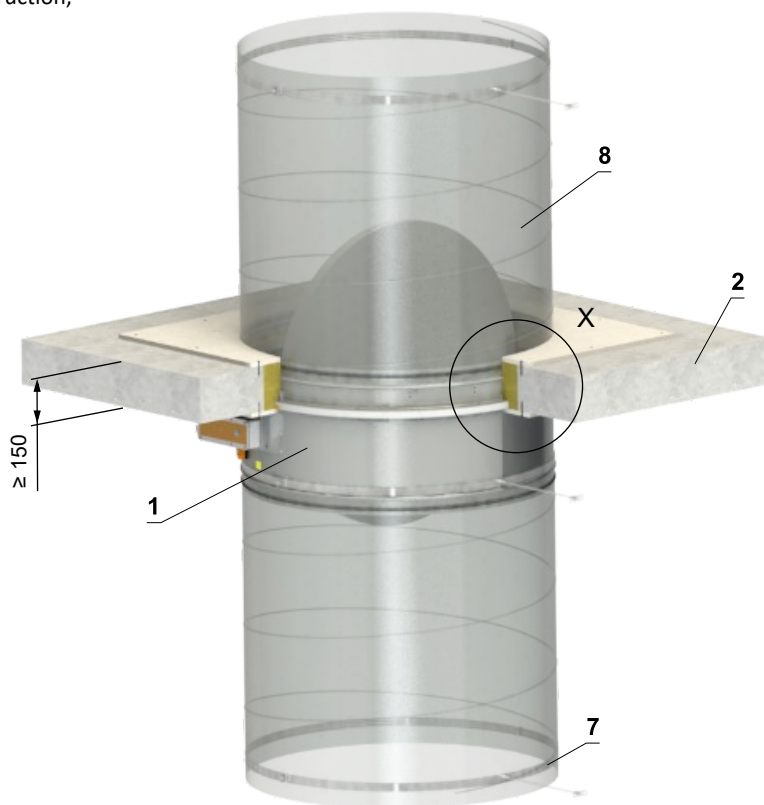
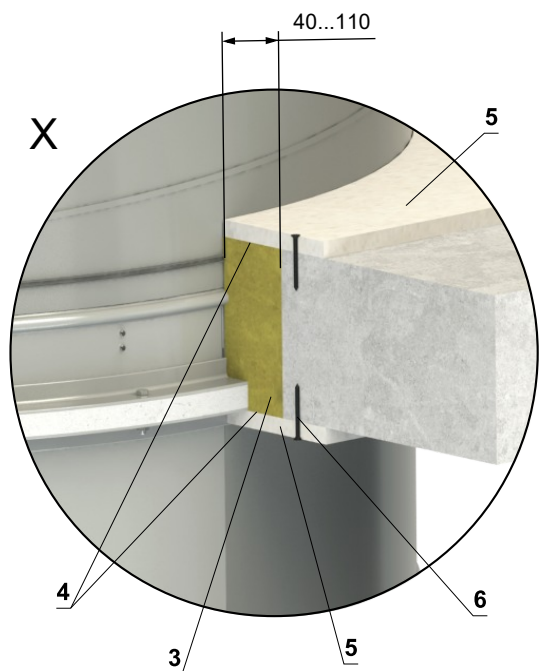

- 1 FDMA-PM
- 2 Solid ceiling construction
- 3 Mineral wool board - min. density 140 kg/m<sup>3</sup> (e.g. PROMAPYR-T150, ROCKWOOL HARDROCK / STEPROCK HD)
- 4 Fire-resistant coating - th. 1 mm (e.g. PROMASTOP-I)
- 5 Fire-resistant board - min. th. 15 mm, min. density 870 kg/m<sup>3</sup> (e.g. PROMATECT-H).
- 6 Screw 4x50 mm - screws must be fixed in the wall construction, use steel anchors if necessary
- 7 Clamp with threaded rod → see pages 46 to 47
- 8 Duct

## Installation outside solid ceiling construction

### Outside solid ceiling construction - mineral wool ROCKWOOL - mortar or gypsum

EI 90 (h<sub>o</sub> i↔o) S

- For connection of following duct → see page 47
- Minimum and maximum distance between the ceiling and fire damper is unlimited
- When installing the insulation, follow the ROCKWOOL manufacturer's instructions
- The damper and the duct must be suspended separately
- The duct must be suspended on both sides of damper acc. to national rules
- Duct between fire damper and fire separating construction must be suspended by using threaded rods and mounting profiles, or another mounting system acc. to national standards
- Load of the suspension system depends on weight of the fire damper and duct system → see page 46
- Max. distance between two suspension systems is 1500 mm
- Following air-conditioning duct must be suspended or supported so that all load transfer from the following duct to the fire damper is absolutely excluded. Adjacent duct must be suspended or supported, as required by the duct suppliers
- If the threaded rod is located inside the duct insulation, distance between threaded rod and duct is max 30 mm
- If the threaded rod is located outside the duct isolation, distance between threaded rod and isolation is max. 40 mm
- The damper can be installed from both sides of the construction, i.e. from the top or the bottom side of the ceiling.

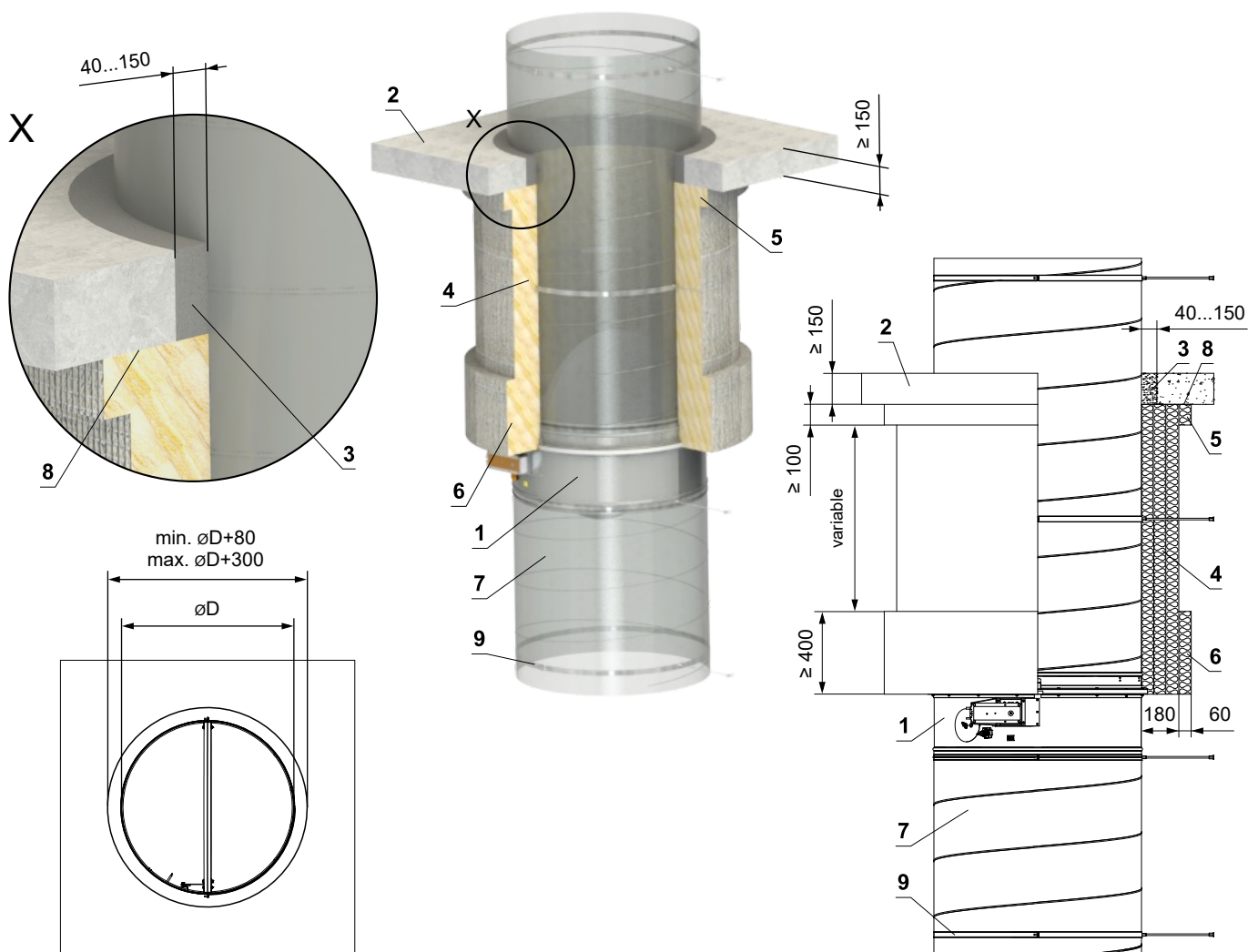

- |  |  |
|--|--|
| <ul style="list-style-type: none"> <li>1 FDMA-PM</li> <li>2 Solid ceiling construction</li> <li>3 Mortar or gypsum</li> <li>4 Insulation mat made of mineral wool, with a surface treatment of aluminum foil - th. 180 mm (3x60 mm), min. density 105 kg/m<sup>3</sup> - (System ROCKWOOL Wired Mat 105 Alu)</li> <li>5 Duct penetration insulation collar - th. 60 mm (System ROCKWOOL Wired Mat 105 Alu) - glued (pos. 8) and fixed with screws to the ceiling construction</li> </ul> | <ul style="list-style-type: none"> <li>6 Insulation collar of the damper and duct connection - th. 60 mm (System ROCKWOOL Wired Mat 105 Alu)</li> <li>7 Standard air duct, made of galvanized sheet metal min. thickness 0,8 mm</li> <li>8 ROCKWOOL Firepro glue - apply on the insulation and fix it to the fire separation construction</li> <li>9 Clamp with threaded rod → see pages 46 to 47</li> </ul> |
|--|--|

Outside solid ceiling construction - concreting

EI 90 (h<sub>o</sub> i↔o) S

- For connection of following duct → see page 47
- The duct must be suspended on both sides of damper acc. to national rules
- Load of the suspension system depends on weight of the fire damper and duct system → see page 46
- Max. distance between two suspension systems is 1500 mm
- Following air-conditioning duct must be suspended or supported so that all load transfer from the following duct to the fire damper is absolutely excluded. Adjacent duct must be suspended or supported, as required by the duct suppliers

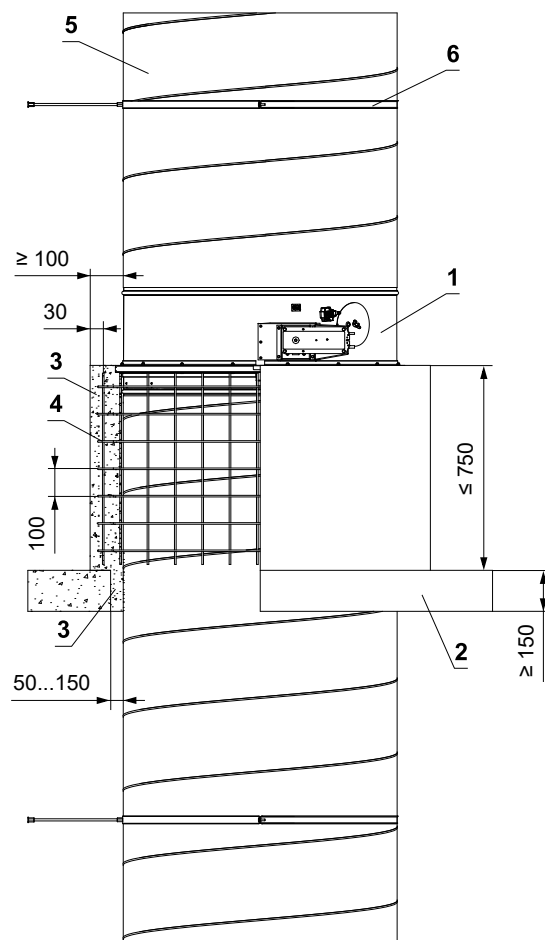
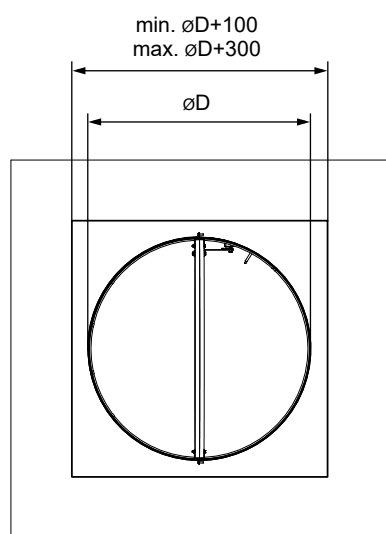
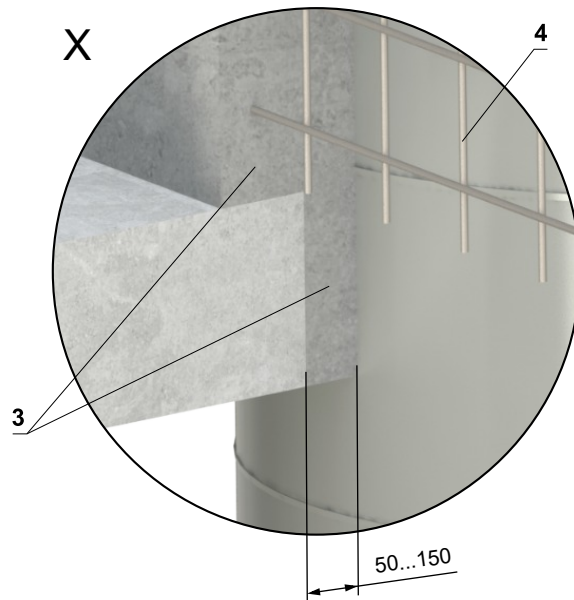
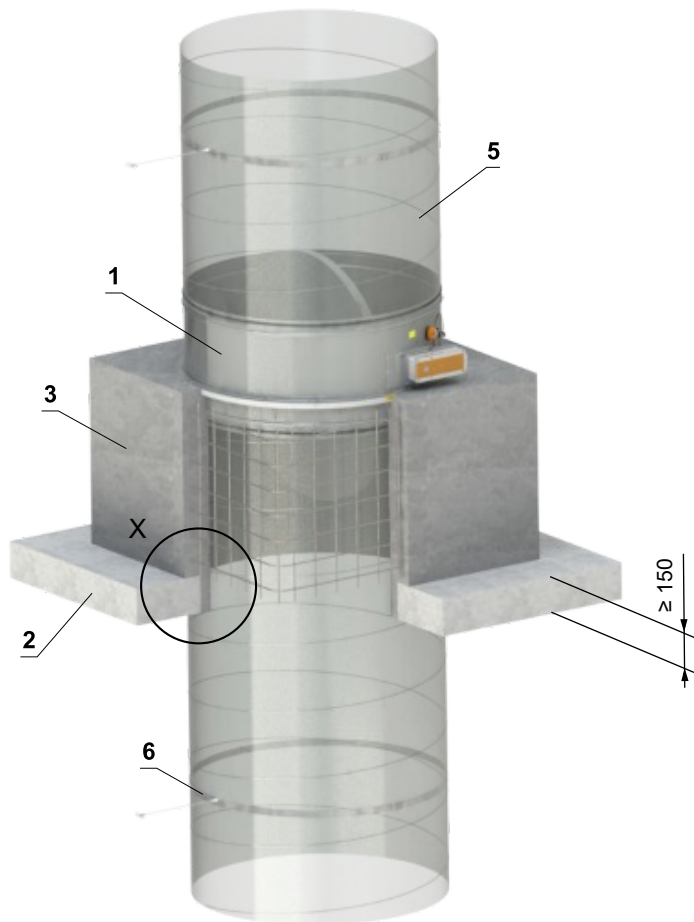

- 1 FDMA-PM
- 2 Solid ceiling construction
- 3 Concrete B20
- 4 Rebar - steel rod  $\varnothing$  6 mm, mesh hole 100 mm
- 5 Standard air duct, made of galvanized sheet metal min. thickness 0,8 mm
- 6 Clamp with threaded rod → see pages 46 to 47

## Installation frames

List of installation frames and installation options

Installation frame	Wall thickness (mm)								
	Solid wall construction			Gypsum wall construction			Solid ceiling construction		
	In construction	Outside construction	On construction	In construction	Outside construction	On construction	In construction	Outside construction	On construction
R1	≥ 100	–	–	≥ 100	–	–	≥ 150	–	–
R2	≥ 150	–	–	≥ 150	–	–	≥ 150	–	–
R3	≥ 100	–	–	≥ 100	–	–	≥ 150	–	–
R4	≥ 150	–	–	≥ 150	–	–	≥ 150	–	–
R5*	–	–	≥ 100	–	–	≥ 100	–	≥ 150	≥ 150
R6	–	≥ 100	–	–	–	–	–	≥ 150	–
R7	–	–	–	≥ 100	–	–	–	–	–

\* Only for SPIRO design

Installation frame R1



Installation frame R2



Installation frame R3



Installation frame R4



Installation frame R5



Installation frame R6



Installation frame R7



- Installation frame can be installed on the damper or delivered separately

# V. SUSPENSION SYSTEMS

## Mounting to the ceiling wall

- The dampers must be suspended using threaded rods and mounting profiles. Their dimensioning depend on the weight of the damper.
- The dampers and the duct must be suspended separately.
- Following air-conditioning duct must be suspended or supported so that all load transfer from the following duct to the damper flanges is absolutely excluded. Adjacent duct must be suspended or supported, as required by the duct suppliers.
- Threaded rods longer than 1,5 m must be protected by fire insulation.

### Examples of anchoring to the ceiling construction Follow the instructions of fixing specialist or installation company

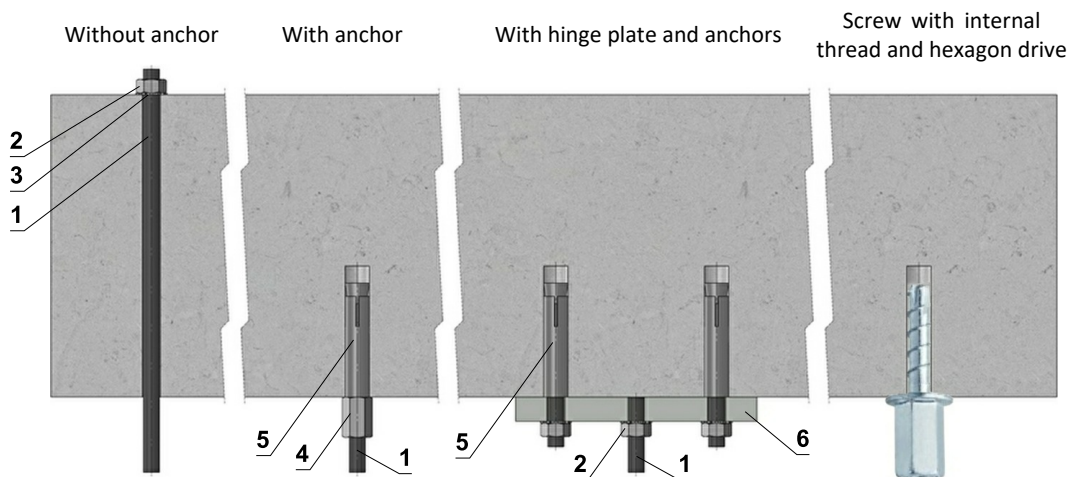

Hinge plates

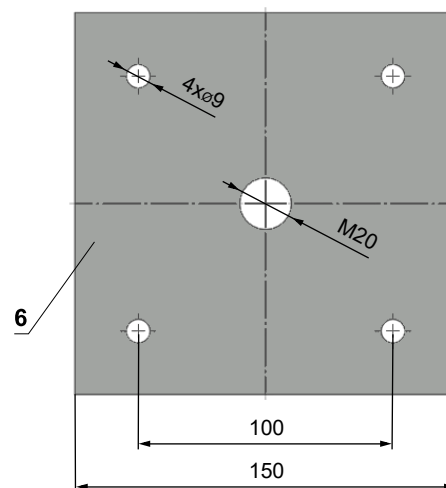
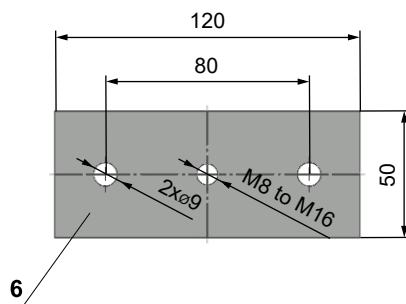

- If in doubt, always consult an anchor specialist engineer such as Halfen or Hilti.

#### Load capacities of threaded rods at the required fire resistance 60 min. <math>t \le 120 \text{ min.}</math>

Size	As [mm <sup>2</sup> ]	Weight [kg]	
		for 1 rod	for 2 rods
M8	36,6	22	44
M10	58	35	70
M12	84,3	52	104
M16	157	96	192
M18	192	117	234
M20	245	150	300

- 1 Threaded rod M8 - M20
- 2 Nut M8 - M20
- 3 Washer for M8 - M20
- 4 Coupling Nut M8 - M20
- 5 Anchor
- 6 Hinge plate - min. thickness 10 mm
- 7 Concrete screw tested for fire resistance R30-R90, max. Tension up to 0.75 KN (length 35 mm)

### Example of duct connection

SPIRO design

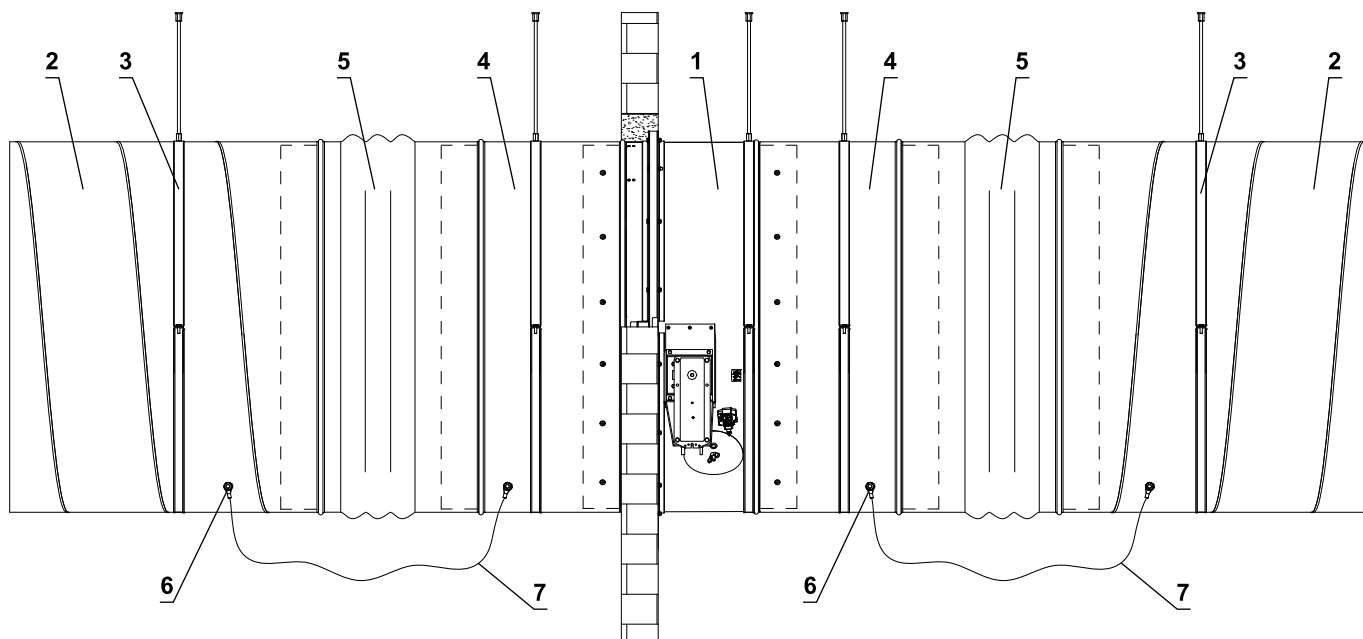

FLANGE design

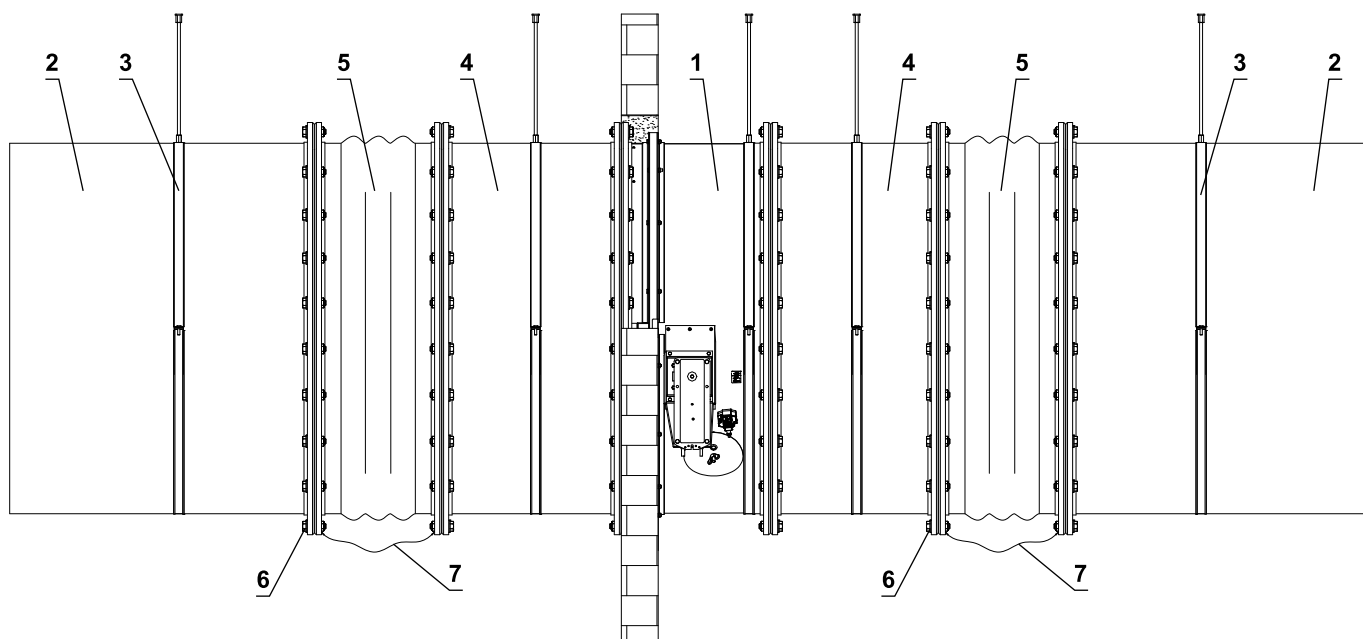

- The method of attachment must follow the minimum requirements for attachment and connection of ductwork in accordance with national regulations. Also, the elements can be suspended from the top, or supported from bottom, or fastened from the side.

- 1 FDMA-PM
- 2 Duct
- 3 Clamp with threaded rod
- 4 Extension piece (if required)
- 5 Damping pad
- 6 Bolt assembly M8 (bolt M8x20 mm, 2 pcs large washer M8, nut M8)
- 7 Protective bonding conductor

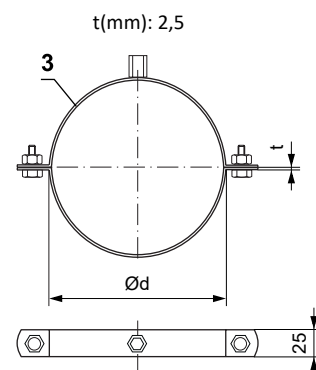

2x screw connection M10x30 or threaded rods M10  
Combined fixing nut for threaded rod M8+M10.

## VI. TECHNICAL DATA

### Pressure loss

#### Pressure loss calculation

$$\Delta p = \xi \cdot \rho \cdot \frac{w^2}{2}$$

$\Delta p$	[Pa]	pressure loss
$w$	[m/s]	air flow speed in nominal damper section
$\rho$	[kg/m <sup>3</sup> ]	air density
$\xi$	[-]	coefficient of local pressure loss for the nominal damper section

#### Determination of pressure loss by using diagram $\rho = 1,2 \text{ kg/m}^3$

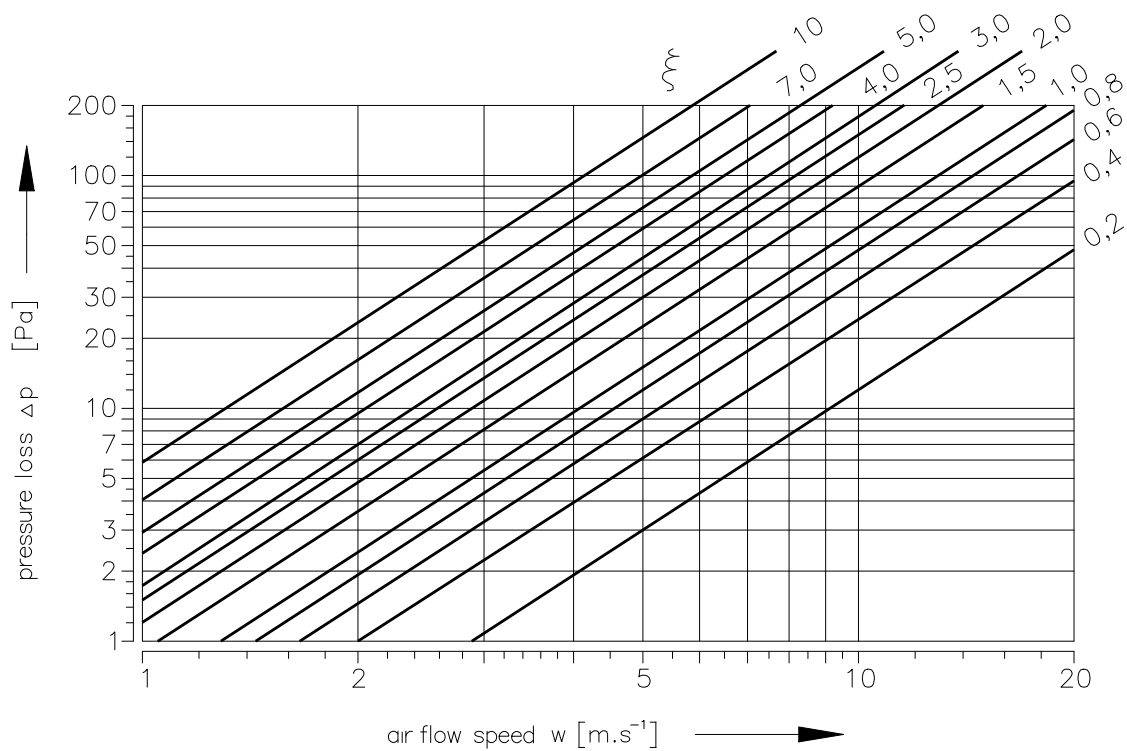

#### Coefficient of local pressure loss

D	900	1000
$\xi$	0,090	0,083

## Noise data

## Level of acoustic output corrected with filter A

$$L_{WA} = L_{W1} + 10 \log(S) + K_A$$

$L_{WA}$	[dB(A)]	level of acoustic output corrected with filter A
$L_{W1}$	[dB]	level of acoustic output $L_{W1}$ related to the 1 m <sup>2</sup> section
$S$	[m <sup>2</sup> ]	duct cross section
$K_A$	[dB]	correction to the weight filter A

## Level of acoustic output in octave ranges

$$L_{Woct} = L_{W1} + 10 \log(S) + L_{rel}$$

$L_{Woct}$	[dB]	spectrum of acoustic output in octave range
$L_{W1}$	[dB]	level of acoustic output $L_{W1}$ related to the 1 m <sup>2</sup> section
$S$	[m <sup>2</sup> ]	duct cross section
$L_{rel}$	[dB]	relative level expressing the shape of the spectrum

## Tables of acoustics values

Level of acoustic output  $L_{W1}$ [dB] related to the 1 m<sup>2</sup> section

w [m/s]	$\xi$ [-]											
	0,1	0,2	0,3	0,4	0,6	0,8	1	1,5	2	2,5	3	3,5
2	9	11,5	14,7	16,9	20,1	22,3	24,1	27,2	29,4	31,2	32,6	33,8
3	16,7	22,1	25,3	27,5	30,7	32,9	34,6	37,8	40	41,7	43,2	44,4
4	24,2	29,6	32,8	35	38,1	40,4	42,1	45,3	47,5	49,2	50,7	51,9
5	30	35,4	38,6	40,8	44	46,2	47,9	51,1	53,3	55,1	56,5	57,7
6	34,8	40,2	43,3	45,6	48,7	51	52,7	55,8	58,1	59,8	61,2	62,4
7	38,8	44,2	47,3	49,6	52,7	55	56,7	59,9	62,1	63,8	65,2	66,4
8	42,3	47,7	50,8	53,1	56,2	58,4	60,2	63,3	65,6	67,3	68,7	69,9
9	45,4	50,7	53,9	56,1	59,3	61,5	63,3	66,4	68,6	70,4	71,8	73
10	48,1	53,5	56,6	58,9	62	64,3	66	69,1	71,4	73,1	74,5	75,7
11	50,6	56	59,1	61,4	64,5	66,7	68,5	71,6	73,9	75,6	77	78,2
12	52,8	58,2	61,4	63,6	66,8	69	70,7	73,9	76,1	77,9	79,3	80,5

Correction to the weight filter A

w [m/s]	2	3	4	5	6	7	8	9	10	11	12
$K_A$ [dB]	-15	-11,8	-9,8	-8,4	-7,3	-6,4	-5,7	-5	-4,5	-4	-3,6

Relative level expressing the shape of the spectrum  $L_{rel}$ 

w [m/s]	f [Hz]							
	63	125	250	500	1000	2000	4000	8000
2	-4,5	-6,9	-10,9	-16,7	-24,1	-33,2	-43,9	-56,4
3	-3,9	-5,3	-8,4	-13,1	-19,5	-27,6	-37,4	-48,9
4	-3,9	-4,5	-6,9	-10,9	-16,7	-24,1	-33,2	-43,9
5	-4	-4,1	-5,9	-9,4	-14,6	-21,5	-30,0	-40,3
6	-4,2	-3,9	-5,3	-8,4	-13,1	-19,5	-27,6	-37,4
7	-4,5	-3,9	-4,9	-7,5	-11,9	-17,9	-25,7	-35,1
8	-4,9	-3,9	-4,5	-6,9	-10,9	-16,7	-24,1	-33,2
9	-5,2	-3,9	-4,3	-6,4	-10,1	-15,6	-22,7	-31,5
10	-5,5	-4	-4,1	-5,9	-9,4	-14,6	-21,5	-30
11	-5,9	-4,1	-4	-5,6	-8,9	-13,8	-20,4	-28,8
12	-6,2	-4,3	-3,9	-5,3	-8,4	-13,1	-19,5	-27,6

## VII. MATERIAL, FINISHING

- Damper casings are made from galvanized sheet metal without further surface treatment.
- Damper blades are made from fire resistant asbestos free boards made of mineral fibres.
- Manual control have cover made of mechanically resistant and durable plastic and the other parts are galvanized without further surface treatment.
- Thermal fuses are made of sheet brass, thickness 0,5 mm.
- Fasteners and springs are galvanized.
- According to the customer's requirements, dampers can be made of stainless steel material.

### Specifications for stainless-steel design:

- Class A2 – Food-grade stainless steel (AISI 304 – EN 1.4301)
- Class A4 – Chemistry-grade stainless steel (AISI 316, 316L – EN 1.4401, EN 1.4404)

The respective stainless steel is the material for all components that are located or entering the damper inner space; components outside the damper casing are typically from galvanised sheet metal (fasteners for mounting the actuator or manual control, mechanical components except Item 4), frame components.

### The following components, including the fasteners, are made from stainless steel at all times:

- 1) Damper casing and all components permanently attached
- 2) Blade holders including pins, metal parts of blades
- 3) Control components inside the damper (L-profile, pin with lever, rod, fasteners)
- 4) Parts of a manual control entering the inner space of a damper casing (lower sheet of a manual control, lock holder "1", lock lever "2", closing spring, 8 dia. stopper pin, manual control pin)
- 5) Inspection opening cover including the stirrup and fasteners (if they are parts of the cover)
- 6) Bearing for torque transfer from the lever with pin on the blade L-profile (made from AISI 440C)

The damper blade is made from a board of homogeneous material Promatect-MST, thickness 40 mm or is composite from two boards of Promatect-H, thickness 20 mm, connected with galvanised nailed "U" connectors which are sealed with Promat K84 from the outside.

Thermal fuse is identical for all material variants of the dampers. Upon specification by customer, the thermal fuse can be made from A4 from stainless steel sheet metal.

Thermoelectric activation device BAT is modified for stainless-steel variant of the dampers; standard galvanised screws are replaced with stainless-steel M4 screws of corresponding class. Damper casing has stainless-steel riveting M4 nuts.

Plastic, rubber and silicon components, sealants, foaming tapes, glass-ceramic seals, housings, brass bearings of the blade, actuators, and end switches are identical for all material variants of the dampers.

Some fasteners and components are only available in one class of stainless steel; the type will be used in all stainless-steel variants.

The damper blade in the variant for chemical environments (Class A4) is always treated with a coating of chemically resistant Promat SR.

Any other requirements for the design will be considered atypical and will be addressed on an individual basis.

## VIII. TRANSPORTATION, STORAGE AND WARRANTY

### Logistic terms

- Dampers are delivered on pallets. As standard, the dampers are wrapped in plastic foil for protection during transport and must not be used for long-term storage. Temperature changes during transport can cause condensation of water inside the packaging and thereby cause corrosion of materials used in the dampers (e.g. white corrosion on zinc-coated items or mould on calcium silicate). Therefore, it is necessary to remove the transport packaging immediately after unloading to allow air to circulate around the product.
- The dampers must be stored in clean, dry, well ventilated and dust-free environment out of direct sunlight. Ensure protection against moisture and extreme temperatures (minimum temperature +5°C). The dampers must be protected against mechanical and accidental damage prior to installation.
- Another required packaging system should be approved and agreed by manufacturer. Packaging material is not returnable in case that another packaging system (material) is required and used and it is not included into final price of damper.
- Dampers are transported by box freight vehicles without direct weather impact, there must not occur any shocks and ambient temperature must not exceed +50°C. Dampers must be protected against impact when transported and manipulated. During transportation, the damper blade must be in the "CLOSED" position.
- Dampers must be stored indoor in environment without any aggressive vapours, gases or dust. Indoor temperature must be in the range from -30°C to +50°C and maximum relative humidity 95%.

### Warranty

- The manufacturer provides a warranty of 24 months from the date of dispatch for the dampers.
- In case of using a Schischek actuator, the manufacturer provides a 12-month warranty for the actuator from the date of shipment.
- The warranty for fire dampers FDMA-PM, provided by the manufacturer, is completely void if actuating, closing and control devices are unprofessionally handled by untrained workers or if electric components, i.e. limit switches, actuators, communication and supply devices and thermoelectric activation devices are dismounted.
- The warranty is void if dampers are used for other purposes, devices and working conditions than those allowed by these technical conditions or if the dampers are mechanically damaged during handling.
- If the dampers are damaged by transport, a record must be written down with the forwarder at reception for later complaint.

## IX. ASSEMBLY, ATTENDANCE AND MAINTENANCE

- Assembly, maintenance and damper function check can be done only by qualified and trained person, i.e. "AUTHORIZED PERSON" according to the manufacturer documentation. All works done on the fire dampers must be done according international and local norms and laws.
- All effective safety standards and directives must be observed during damper assembly.
- To ensure reliable damper function it is necessary to avoid blocking the actuating mechanism and contact surfaces with collected dust, fibre and sticky materials and solvents.
- Flange and screw joints must be conductively connected to protect against dangerous contact. 2 galvanized lock washers that are placed under the head of one screw and a fastened nut are used for conductive connection.

### Manual operation - actuator control without electric voltage

- A special wrench (part of the actuator) can be used to manually turn the damper blade to any position. When the wrench is turned in the direction of the arrow, the damper blade rotates to its open position. As the blade rotation is stopped, in every position, the actuator will be locked. Unlocking is possible even manually as per instructions on the actuator, or by the activation of the supply voltage.
- If the actuator is manually locked, the damper blade will not close in the event of a fire after the activation of the thermoelectric activation device BAT. To restore correct damper operation, the actuator must be unlocked (manually or by applying power supply).

### Limit switches

- If the damper is equipped with limit switches and these switches are not used during operation (e.g. because of a project change), they can be left on the damper and not connected (they need not be dismantled).
- On the other hand, if the limit switch is to be added to the damper design, the change can be implemented by change kit.
- These facts must be recorded in the respective operation documentation of the damper (record books of the damper, fire logs, etc.) and subsequently, adequate function checks must be carried out.

### Installation / fixing the damper

- The damper casing shall not be deformed in the course of bricking in.
- Once the damper is built in, the damper blade shall not grind on the damper casing during opening or closing.

#### Protection of the damper casing against buckling during installation!

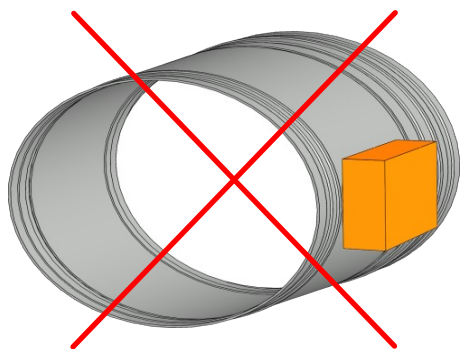

**WRONG!**

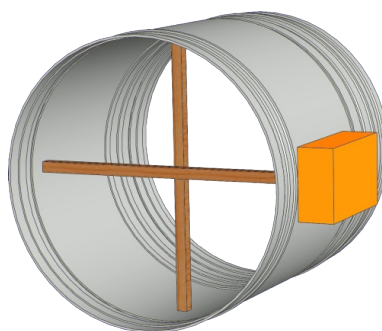

**Brace with wooden blocks**

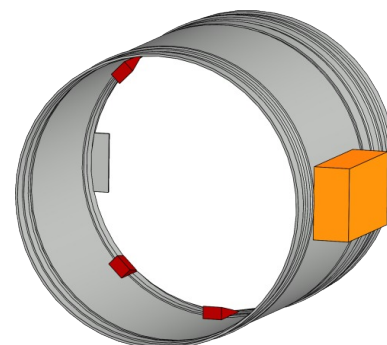

**Brace with wedges**

## Change of manual control for the actuator or vice versa

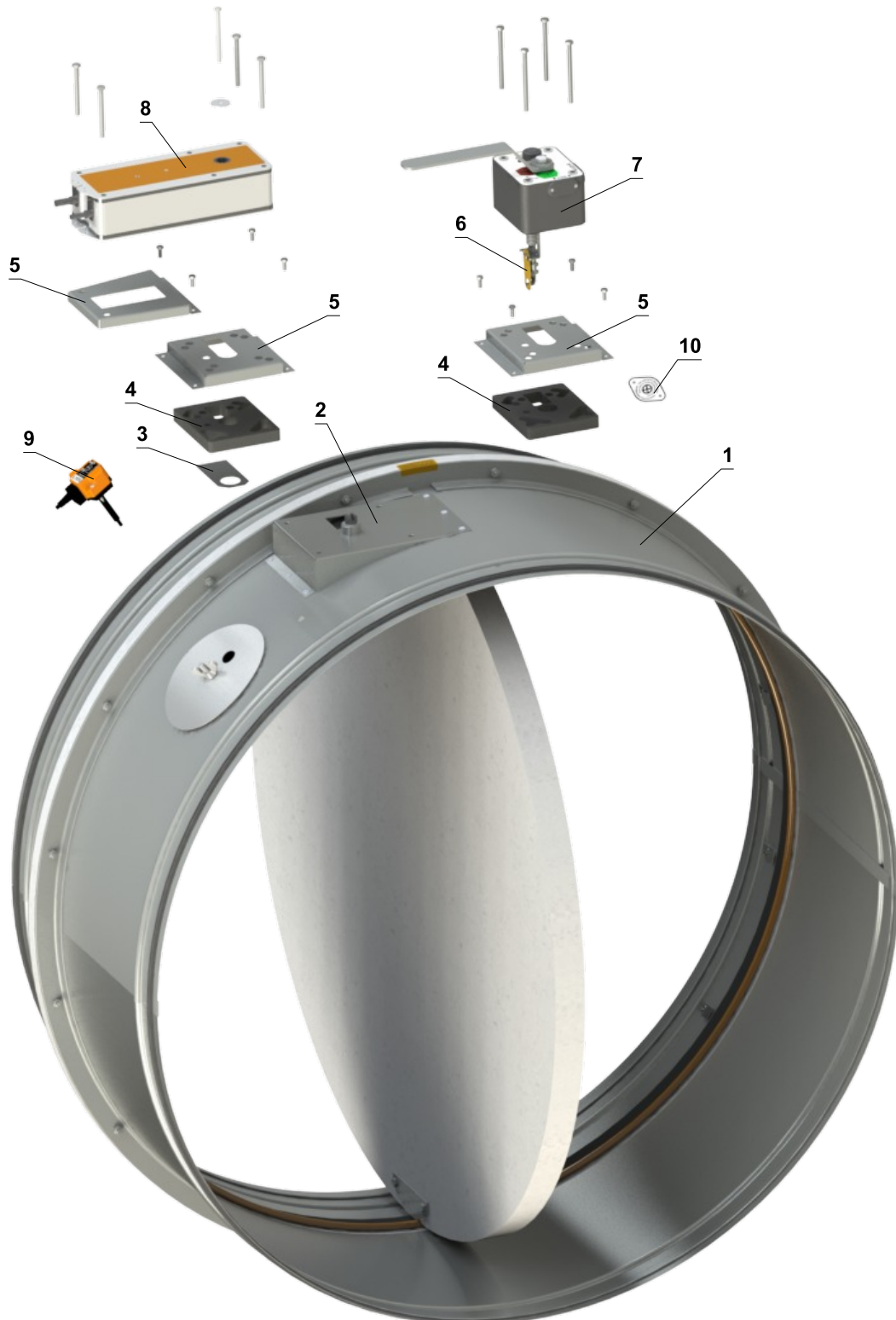

- 1 Damper
- 2 Mounting plate
- 3 Sealing cover
- 4 Sealing of a mounting plate
- 5 Cover of mounting plate
- 6 Thermal fuse
- 7 Manual control
- 8 Spring return actuator
- 9 Thermoelectric activation device BAT
- 10 Sensor sticker

## Commissioning and revisions

- Before putting the damper into operation, serviceability checks and functional tests must be carried out including testing of functionality of all electrical elements. After putting into operation these serviceability checks must be carried at least twice a year. If no defect is found during two subsequent serviceability checks, these checks can be carried out once a year.
- In case that dampers are found unable to serve for their function for any cause, it must be clearly marked. The operator is obliged to ensure that the damper is put into condition in which it is ready for function and meanwhile he is obliged to provide the fire protection by another appropriate way.
- Results of regular checks, imperfections found and all important facts connected with the damper function must be recorded in the "FIRE BOOK" and immediately reported to the operator.
- Before entering the dampers with actuator into operation after their assembly and by sequential checks. Check of blade rotation into the breakdown position "CLOSED" can be done after disconnecting the actuator supply (e.g. by pressing the test button at the thermoelectric activation device BAT or disconnecting the supply from ELECTRICAL FIRE SIGNALISATION). Check of blade rotation back into the "OPEN" position can be done after restoration of power supply (e.g. by releasing the test button or restoration of supply from ELECTRICAL FIRE SIGNALISATION). Without power supply, the damper can be operated manually and fixed in any required position. Release of the locking mechanism can be achieved manually or automatically by applying the supply voltage. It is recommended to provide periodical checks, maintenance and service actions on fire equipment by authorized persons. The authorized persons can be trained by producer, or by authorized distributor. All effective safety standards and directives must be observed during fire damper assembly.
- Visual inspection of proper damper installation, inner area of a damper, damper blade, contact surfaces and silicon seal.
- For regular or exceptional inspection of interior of fire damper, micro-camera device can be used. On each fire damper is an inspection opening. In the case of inspection by camera, take out the black rubber cap, insert the camera inside the damper, check interior and at the end of inspection, put the rubber cap back tightly to cover the empty hole.

**For dampers with manual control (designs .01, .11, .80), the following checks must be carried out**

### Check of a manual control and thermal fuse

- **To check the function of the manual control proceed as follows:**
- Turn the damper blade to "CLOSED" position as follows:
  - The damper blade is in "OPEN" position.
  - Press the control button of the manual control to turn the damper blade to "CLOSED" position.
  - Check the damper blade rotation to "CLOSED" position.
  - Damper blade closing shall be smooth and fast, the control lever shall be in „CLOSED“ position.
- Turn the damper blade to "OPEN" position as follows:
  - Turn the control lever by 90°.
  - Check the damper blade rotation to "OPEN" position.
  - The lever will automatically lock in "OPEN" position.
- **Check of function and condition of the thermal fuse:**
  - To check the function and the status of the fuse it's possible to remove the manual control from the casing of the fire damper which is attached to the damper casing with four screws M6.
  - Removing the thermal fuse from the fuse holder of a manual control, checks its correct functionality.
  - The manual control is identified as M1 to M5, depending on the closing spring strength.

### For the designs with actuators, following checks must be carried out

- Check the rotation of the blade to "CLOSED" failure position after disconnection the power supply of the actuator (e.g. by pressing the test button on the thermoelectric activation device BAT or by disconnection the power supply from electrical fire signalization). Check the rotation of the blade back to "OPEN" position by restoring the power supply to the actuator (e.g. by releasing the test button or by restoring the power supply from electrical fire signalization).

### Before putting the dampers into operation and during subsequent function checks, the following checks must be carried out for dampers with optical smoke detector

- The function checks of the optical smoke detector are to be carried out by employees of an authorized organization who have corresponding electrotechnical qualification and have been properly trained by the manufacturer. The function checks are to be carried out as a part of function checks of the fire dampers, at least 1x a year.
- For the function checks, the damper blade should be in "CLOSED" position with the fan off or with closed air regulation situated between the fan and the fire damper.
- Inspection opening disassembly
  - Release the covering lid by turning the wing nut and while turning the lid right or left release it from the security belt. Then tilt the lid and remove it from its original position.



*Inspection opening detail*

- Ensure each damper is fully checked for operational capability, control should be initiated from the control system or by manual control. Damper blades should open and close correctly and operation should be visually inspected and documented prior to handover.

### How to proceed after Tf1 or Tf2 fuses have been activated

- If the thermal fuse **Tf1** is interrupted (due to temperature outside the duct), it is necessary to replace the spring return actuator. → see page 9
- If the thermal fuse **Tf2** is interrupted (due to temperature inside the duct), only the spare part ZBAT 72 (95/120/140) needs to be replaced (acc.to the activation temperature). → see page 9

# X. ORDERING INFORMATIONS

## Ordering key



**EXAMPLES:**

**FDMA-PM EN DN 900/375 .40 RS-ZN**

Fire damper FDMA-PM, dimension DN 900 mm, built length 375 mm, control design with spring return actuator AC 230 V, standard activation temperature 72 °C, straight connection to circular duct, galvanized material variant, without installation kit/frame, standard silicon seal.

**FDMA-PM EN DN 900/375 .40 120 R1 RS-ZN IW G**

Fire damper FDMA-PM, dimension DN 900 mm, built length 375 mm, control design with spring return actuator AC 230 V, activation temperature 120 °C, with installation frame R1, straight connection to circular duct, galvanized material variant, impregnation against humidity, Silicone-free rubber.

**1| Fire damper type - FDMA-PM**

**2| Country of destination**

**3| Damper dimensions ØD → see page 15**

**4| Built length - 375 mm**

**5| Damper design**

.01	Manual control and thermal
.02 *	Manual control and thermal (Zone 1,2)
.11	Manual control and thermal with a terminal switch („CLOSED“)
.12 *	Manual control and thermal with a terminal switch („CLOSED“) (Zone 1,2)
.80	Manual control and thermal with two terminal switches („OPEN“, „CLOSED“)
.81 *	Manual control and thermal with two terminal switches („OPEN“, „CLOSED“) (Zone 1,2)
.40	With actuator BF 230-TN - voltage AC 230 V
.41	With actuator BF 24-TN, with smoke detector ORS 142 K and with supply device BKN 230-24-MOD (voltage AC 230 V)
.42 *,**	With actuator ExMax-15-BF, with thermoelectric activation device ExPro-TT (Zone 1,2) - supply voltage range 24 to 230 VAC/DC
.50	With actuator BF 24-TN - voltage AC/DC 24 V
.51	With actuator BF 24-TN , with smoke detector ORS 142 K (voltage AC/DC 24 V)
.63	With communication and supply device BKN 230-24-MOD, with actuator BF 24-TN-ST
.63S	With communication and supply device BKN 230-24-MOD, with actuator BF 24-TN-ST and with smoke detector ORS 142 K

\* Not possible to order with fire resistance class EI 120 (v<sub>e</sub> h<sub>o</sub> i↔o) S.

\*\* These designs are supplied only with an activation temperature of 72 °C.

■ Detailed information for ATEX dampers (ZONE 1,2) → see Appendix

**6| Activation temperature**

Manual control		Spring return actuator control	
	72 °C *		72 °C *
104	104 °C	95	95 °C
147	147 °C	120	120 °C
		140	140 °C

\* Standard activation temperature

**8| Duct connection**

RS	Straight connection to circular duct
RF	Flanged connection to circular duct

**7| Installation kit/frame**

Without installation kit/frame	
R1	Installation frame R1
R2	Installation frame R2
R3	Installation frame R3
R4	Installation frame R4
R5	Installation frame R5
R6	Installation frame R6
R7	Installation frame R7

**9| Material and other design options**

ZN	Galvanized
A2	Stainless steel 1.4301 (AISI 304)
A4	Stainless steel 1.4404 (AISI 316L) - included damper blade impregnation against chemical - type PROMAT SR

**10| Surface treatment**

	Without surface treatment
IW	Damper blade impregnation, impregnating agent PROMAT 2000 - impregnation against humidity
IA	Damper blade impregnation, impregnating agent PROMAT SR - impregnation against chemical

**11| Cold seal variant**

	Silicone rubber *
G	Silicone-free rubber

\* Standard cold seal

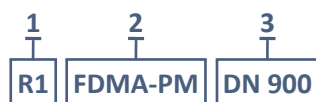
**Accessories****Installation frame R**

**1| Installation frame type R1/R2/R3/R4/R5/R6/R7**

**2| Fire damper type - FDMA-PM**

**3| Damper dimensions  $\varnothing D$  → see pages 15**

## Data label

- Data label is placed on the damper casing (example)

<b>MANDÍK</b> <sup>®</sup>		MANDÍK, a.s. Dobříšská 550, 267 24 Hostomice, Czech Republic	
FIRE DAMPER - XXXX		 MANUAL	
DIMENSION:			
SERIAL.NO.:		WEIGHT (kg):	
CLASSIFICATION:			
TPM XXX/XX	Cert. No.: 1391-CPR-XXXX/XXXX, DoP: PM/XXXX/XX/XX/X	XX	EN 15650:2010

The producer reserves the right for innovations of the product.  
For actual product information see [www.mandik.com](http://www.mandik.com)

**MANDÍK**<sup>®</sup>  
[www.mandik.com](http://www.mandik.com)

